

Draft Environmental Impact Report (Draft EIR)

[State Clearinghouse No. 2008121080]

for

Los Angeles International Airport (LAX) Bradley West Project

(formerly Los Angeles International Airport [LAX] Tom Bradley International Terminal [TBIT] Reconfiguration Project)

Volume 4

Appendices C-5 through C-9

City of Los Angeles
Los Angeles City File No. AD 043-08

May 2009

BRADLEY WEST PROJECT

Appendix C-5
LAX Bradley West Project Draft EIR

Level of Service Worksheets

May 2009

Prepared for:

Los Angeles World Airports
One World Way
Los Angeles, California 90045

Prepared by:

Fehr & Peers Transportation Consultants
201 Santa Monica Boulevard, Suite 500
Santa Monica, CA 90401

INTERSECTION DATA SUMMARY SHEET

N/S: W/E: I/S No:

AM/PM: Comments:

COUNT DATE: STUDY DATE: GROWTH FACTOR:

	NORTHBOUND			SOUTHBOUND			WESTBOUND			EASTBOUND		
	LT	TH	RT	LT	TH	RT	LT	TH	RT	LT	TH	RT
EXISTING	119	579	141	78	757	94	154	532	158	42	266	122
AMBIENT												
RELATED												
PROJECT												
TOTAL	119	579	141	78	757	94	154	532	158	42	266	122
LANE	1	2	1	1	3	1	1	1	1	1	2	1
SIGNAL	Prot-Fix		Auto	Prot-Fix		Auto	Prot-Fix		Auto	Prot-Fix		Auto

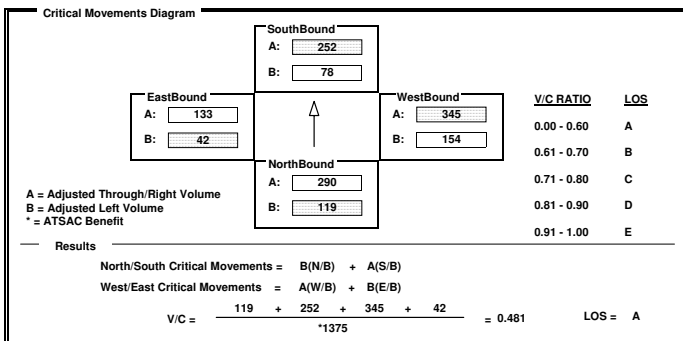

INTERSECTION DATA SUMMARY SHEET

N/S: W/E: I/S No:

AM/PM: Comments:

COUNT DATE: STUDY DATE: GROWTH FACTOR:

	NORTHBOUND			SOUTHBOUND			WESTBOUND			EASTBOUND		
	LT	TH	RT	LT	TH	RT	LT	TH	RT	LT	TH	RT
EXISTING	22	43	42	268	25	287	77	1817	461	402	957	27
AMBIENT												
RELATED												
PROJECT												
TOTAL	22	43	42	268	25	287	77	1817	461	402	957	27
LANE	1	2	1	2	1	1	1	4	1	2	4	1
SIGNAL	Split		Auto	Split		Auto	Prot-Fix		OLA	Prot-Fix		Auto

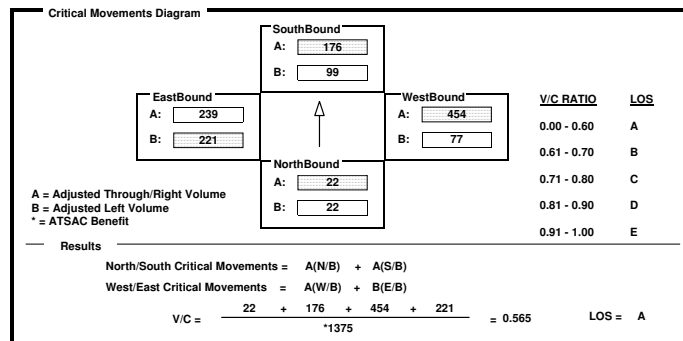

INTERSECTION DATA SUMMARY SHEET

N/S: W/E: I/S No:

AM/PM: Comments:

COUNT DATE: STUDY DATE: GROWTH FACTOR:

	NORTHBOUND			SOUTHBOUND			WESTBOUND			EASTBOUND		
	LT	TH	RT	LT	TH	RT	LT	TH	RT	LT	TH	RT
EXISTING	74	236	467	105	83	23	628	574	39	20	508	24
AMBIENT												
RELATED												
PROJECT												
TOTAL	74	236	467	105	83	23	628	574	39	20	508	24
LANE	1	2	1	1	3	1	2	1	1	1	2	1
SIGNAL	Split		OLA	Split		Auto	Prot-Fix		Auto	Prot-Fix		Auto

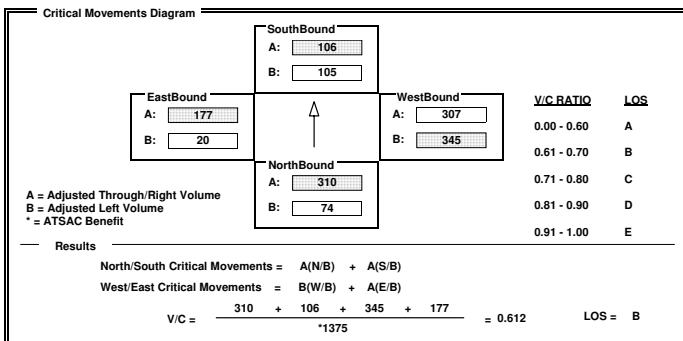

INTERSECTION DATA SUMMARY SHEET

N/S: W/E: I/S No:

AM/PM: Comments:

COUNT DATE: STUDY DATE: GROWTH FACTOR:

	NORTHBOUND			SOUTHBOUND			WESTBOUND			EASTBOUND		
	LT	TH	RT	LT	TH	RT	LT	TH	RT	LT	TH	RT
EXISTING	116	537	74	60	696	25	122	1147	202	22	607	50
AMBIENT												
RELATED												
PROJECT												
TOTAL	116	537	74	60	696	25	122	1147	202	22	607	50
LANE	1	2	1	1	1	1	1	2	1	1	2	1
SIGNAL	Prot-Fix		Auto	Prot-Fix		Auto	Prot-Fix		Auto	Prot-Fix		Auto

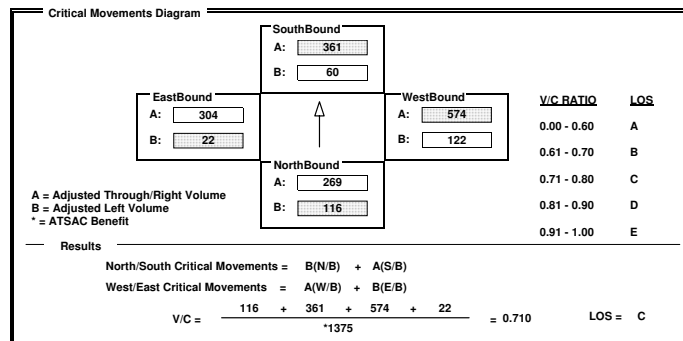

INTERSECTION DATA SUMMARY SHEET

N/S: Aviation Blvd W/E: Arbor Vitae St I/S No: 10
 AM/PM: AM Comments: Existing
 COUNT DATE: STUDY DATE: GROWTH FACTOR:

	NORTHBOUND			SOUTHBOUND			WESTBOUND			EASTBOUND		
	LT	TH	RT	LT	TH	RT	LT	TH	RT	LT	TH	RT
EXISTING	250	481	107	56	437	119	63	551	94	74	229	151
AMBIENT												
RELATED												
PROJECT												
TOTAL	250	481	107	56	437	119	63	551	94	74	229	151
LANE	1	2	1	1	1	1	1	1	1	1	1	1
SIGNAL	Phasing: Perm	RTOR: Auto		Phasing: Perm	RTOR: Auto		Phasing: Perm	RTOR: Auto		Phasing: Perm	RTOR: Auto	

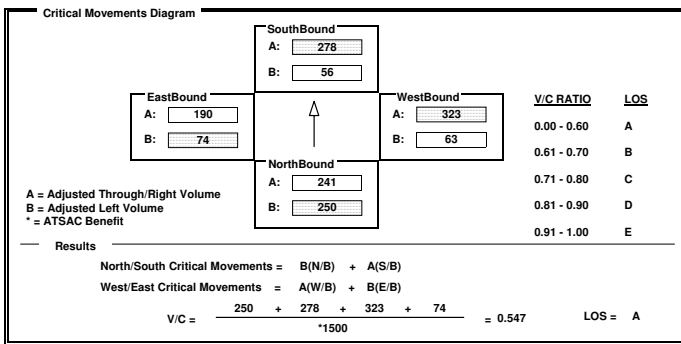

INTERSECTION DATA SUMMARY SHEET

N/S: Aviation Blvd W/E: Century Blvd I/S No: 14
 AM/PM: AM Comments: Existing
 COUNT DATE: STUDY DATE: GROWTH FACTOR:

	NORTHBOUND			SOUTHBOUND			WESTBOUND			EASTBOUND		
	LT	TH	RT	LT	TH	RT	LT	TH	RT	LT	TH	RT
EXISTING	709	565	55	59	385	155	88	1706	141	110	942	244
AMBIENT												
RELATED												
PROJECT												
TOTAL	709	565	55	59	385	155	88	1706	141	110	942	244
LANE	2	1	1	2	2	1	1	3	1	1	3	1
SIGNAL	Phasing: Prot-Fix	RTOR: Auto		Phasing: Prot-Fix	RTOR: OLA		Phasing: Prot-Fix	RTOR: Auto		Phasing: Prot-Fix	RTOR: Auto	

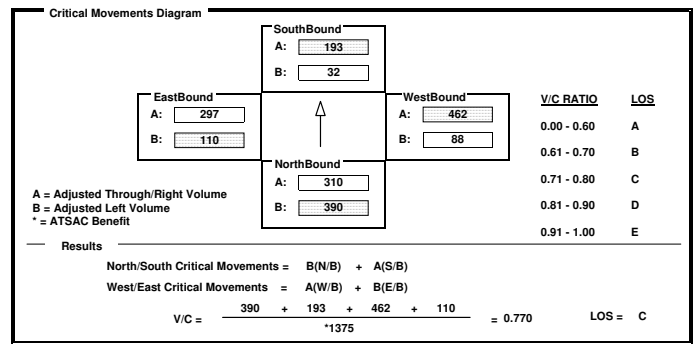

INTERSECTION DATA SUMMARY SHEET

N/S: Aviation Blvd W/E: Imperial Hwy I/S No: 16
 AM/PM: AM Comments: Existing
 COUNT DATE: STUDY DATE: GROWTH FACTOR:

	NORTHBOUND			SOUTHBOUND			WESTBOUND			EASTBOUND		
	LT	TH	RT	LT	TH	RT	LT	TH	RT	LT	TH	RT
EXISTING	240	628	126	185	293	179	293	987	733	114	272	92
AMBIENT												
RELATED												
PROJECT												
TOTAL	240	628	126	185	293	179	293	987	733	114	272	92
LANE	2	2	1	2	1	1	2	3	1	2	2	1
SIGNAL	Phasing: Prot-Fix	RTOR: OLA		Phasing: Prot-Fix	RTOR: OLA		Phasing: Prot-Fix	RTOR: OLA		Phasing: Prot-Fix	RTOR: Auto	

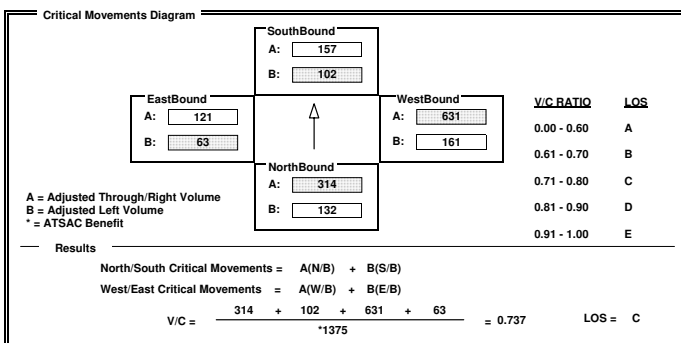

INTERSECTION DATA SUMMARY SHEET

N/S: Lincoln Blvd W/E: Bali Way I/S No: 21
 AM/PM: AM Comments: Existing
 COUNT DATE: STUDY DATE: GROWTH FACTOR:

	NORTHBOUND			SOUTHBOUND			WESTBOUND			EASTBOUND		
	LT	TH	RT	LT	TH	RT	LT	TH	RT	LT	TH	RT
EXISTING	81	1489	29	30	983	198	1	0	15	195	0	38
AMBIENT												
RELATED												
PROJECT												
TOTAL	81	1489	29	30	983	198	1	0	15	195	0	38
LANE	1	2	1	1	2	1		1		1	1	1
SIGNAL	Phasing: Prot-Fix	RTOR: Auto		Phasing: Prot-Fix	RTOR: Auto		Phasing: Prot-Fix	RTOR: Auto		Phasing: Prot-Fix	RTOR: Auto	

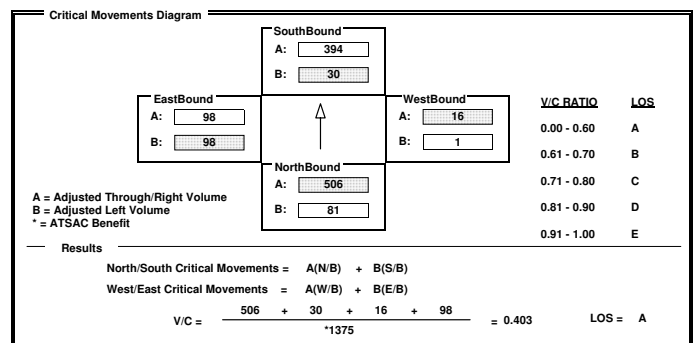

INTERSECTION DATA SUMMARY SHEET

N/S: Lincoln Blv W/E: Bluff Creek Dr I/S No: 22
 AM/PM: AM Comments: Existing
 COUNT DATE: STUDY DATE: GROWTH FACTOR:

	NORTHBOUND			SOUTHBOUND			WESTBOUND			EASTBOUND		
	LT	TH	RT	LT	TH	RT	LT	TH	RT	LT	TH	RT
EXISTING	0	2004	0	0	1646	0	0	0	0	0	0	0
AMBIENT												
RELATED												
PROJECT												
TOTAL	0	2004	0	0	1646	0	0	0	0	0	0	0
LANE	[Lane Diagram]			[Lane Diagram]			[Lane Diagram]			[Lane Diagram]		
SIGNAL	Phasing <none>		RTOR Auto	Phasing <none>		RTOR Auto	Phasing <none>		RTOR Auto	Phasing <none>		RTOR Auto

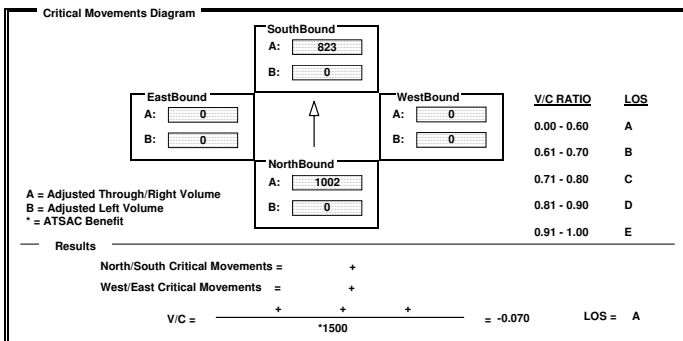

INTERSECTION DATA SUMMARY SHEET

N/S: La Tijera Blvd W/E: Centinela Ave I/S No: 27
 AM/PM: AM Comments: Existing
 COUNT DATE: STUDY DATE: GROWTH FACTOR:

	NORTHBOUND			SOUTHBOUND			WESTBOUND			EASTBOUND		
	LT	TH	RT	LT	TH	RT	LT	TH	RT	LT	TH	RT
EXISTING	287	806	119	26	957	171	183	1180	6	107	399	56
AMBIENT												
RELATED												
PROJECT												
TOTAL	287	806	119	26	957	171	183	1180	6	107	399	56
LANE	[Lane Diagram]			[Lane Diagram]			[Lane Diagram]			[Lane Diagram]		
SIGNAL	Phasing Prot-Fix		RTOR Auto	Phasing Prot-Fix		RTOR Auto	Phasing Prot-Fix		RTOR Auto	Phasing Prot-Fix		RTOR Auto

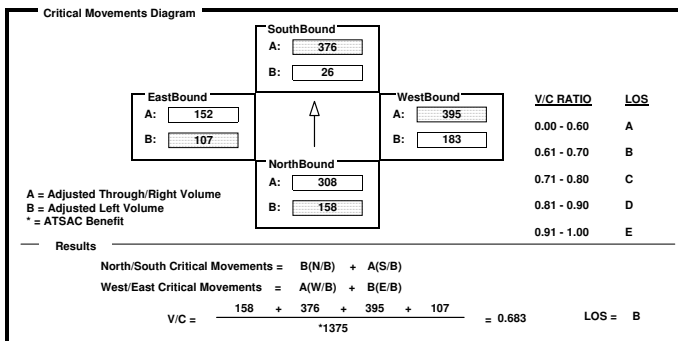

INTERSECTION DATA SUMMARY SHEET

N/S: La Cienega Blvd W/E: Century Blvd I/S No: 36
 AM/PM: AM Comments: Existing
 COUNT DATE: STUDY DATE: GROWTH FACTOR:

	NORTHBOUND			SOUTHBOUND			WESTBOUND			EASTBOUND		
	LT	TH	RT	LT	TH	RT	LT	TH	RT	LT	TH	RT
EXISTING	131	402	198	127	501	539	304	1357	501	94	640	361
AMBIENT												
RELATED												
PROJECT												
TOTAL	131	402	198	127	501	539	304	1357	501	94	640	361
LANE	[Lane Diagram]			[Lane Diagram]			[Lane Diagram]			[Lane Diagram]		
SIGNAL	Phasing Prot-Fix		RTOR OLA	Phasing Prot-Fix		RTOR OLA	Phasing Prot-Fix		RTOR Auto	Phasing Prot-Fix		RTOR OLA

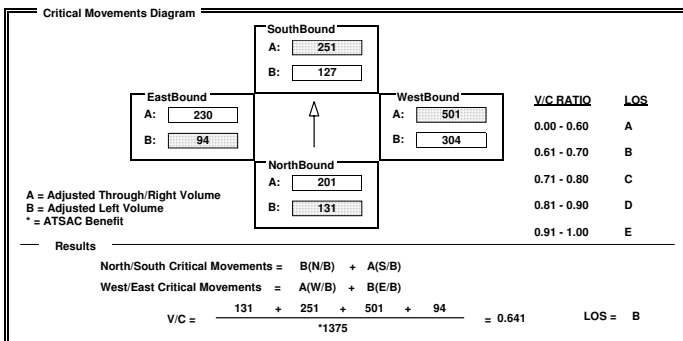

INTERSECTION DATA SUMMARY SHEET

N/S: Sepulveda Blvd W/E: Century Blvd I/S No: 38
 AM/PM: AM Comments: Existing
 COUNT DATE: STUDY DATE: GROWTH FACTOR:

	NORTHBOUND			SOUTHBOUND			WESTBOUND			EASTBOUND		
	LT	TH	RT	LT	TH	RT	LT	TH	RT	LT	TH	RT
EXISTING	0	3211	24	0	1718	194	305	48	256	0	0	0
AMBIENT												
RELATED												
PROJECT												
TOTAL	0	3211	24	0	1718	194	305	48	256	0	0	0
LANE	[Lane Diagram]			[Lane Diagram]			[Lane Diagram]			[Lane Diagram]		
SIGNAL	Phasing Perm		RTOR Free	Phasing Perm		RTOR Auto	Phasing Split		RTOR Auto	Phasing <none>		RTOR Auto

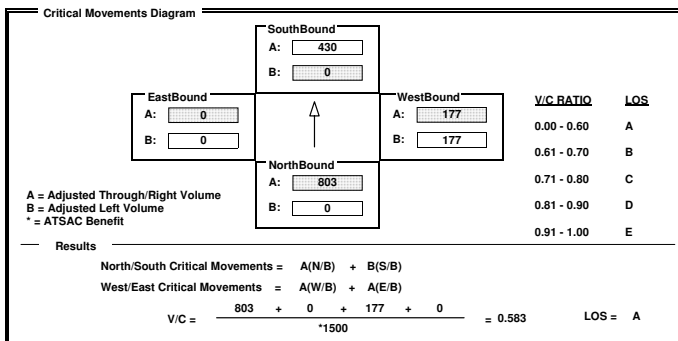

INTERSECTION DATA SUMMARY SHEET

N/S: Douglas St W/E: Imperial Hwy I/S No: 47
 AM/PM: AM Comments: Existing
 COUNT DATE: STUDY DATE: GROWTH FACTOR:

	NORTHBOUND			SOUTHBOUND			WESTBOUND			EASTBOUND		
	LT	TH	RT	LT	TH	RT	LT	TH	RT	LT	TH	RT
EXISTING	57	18	85	15	9	25	113	1114	86	27	440	101
AMBIENT												
RELATED												
PROJECT												
TOTAL	57	18	85	15	9	25	113	1114	86	27	440	101
LANE	1	1	2	1	1	1	2	2	1	1	2	1
SIGNAL	Split	OLA	Split	Auto	Prot-Fix	Auto	Prot-Fix	Auto	Prot-Fix	Auto	Prot-Fix	Auto

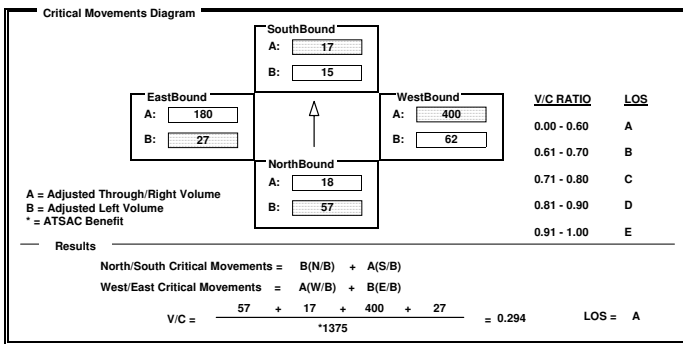

INTERSECTION DATA SUMMARY SHEET

N/S: Lincoln Blvd W/E: Fiji Way I/S No: 56
 AM/PM: AM Comments: Existing
 COUNT DATE: STUDY DATE: GROWTH FACTOR:

	NORTHBOUND			SOUTHBOUND			WESTBOUND			EASTBOUND		
	LT	TH	RT	LT	TH	RT	LT	TH	RT	LT	TH	RT
EXISTING	575	1858	48	67	1103	60	28	17	21	102	23	582
AMBIENT												
RELATED												
PROJECT												
TOTAL	575	1858	48	67	1103	60	28	17	21	102	23	582
LANE	2	2	1	1	2	1	1	1	1	1	1	1
SIGNAL	Prot-Fix	Auto	Prot-Fix	Auto	Perm	Auto	Perm	Auto	Perm	Free	Prot-Fix	Auto

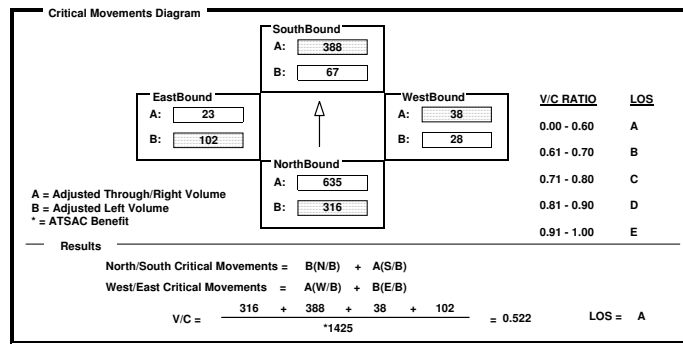

INTERSECTION DATA SUMMARY SHEET

N/S: Sepulveda Blvd W/E: Howard Hughes Pkwy I/S No: 65
 AM/PM: AM Comments: Existing
 COUNT DATE: STUDY DATE: GROWTH FACTOR:

	NORTHBOUND			SOUTHBOUND			WESTBOUND			EASTBOUND		
	LT	TH	RT	LT	TH	RT	LT	TH	RT	LT	TH	RT
EXISTING	0	1914	854	186	918	0	457	0	323	0	0	0
AMBIENT												
RELATED												
PROJECT												
TOTAL	0	1914	854	186	918	0	457	0	323	0	0	0
LANE		4	1	2	3		3		1			
SIGNAL	<none>	Free	Prot-Fix	Auto	Split	Auto	<none>	<none>	<none>	<none>	<none>	<none>

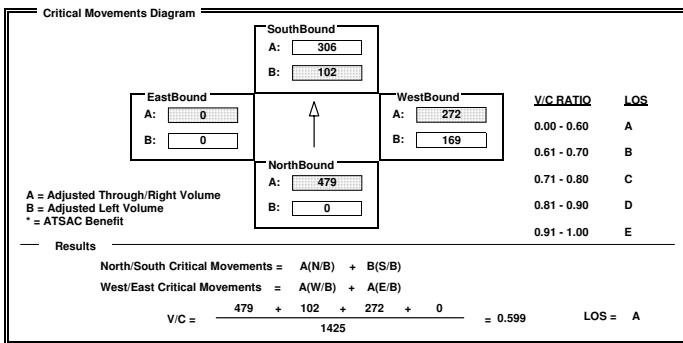

INTERSECTION DATA SUMMARY SHEET

N/S: La Cienega Blvd W/E: Imperial Hwy I/S No: 67
 AM/PM: AM Comments: Existing
 COUNT DATE: STUDY DATE: GROWTH FACTOR:

	NORTHBOUND			SOUTHBOUND			WESTBOUND			EASTBOUND		
	LT	TH	RT	LT	TH	RT	LT	TH	RT	LT	TH	RT
EXISTING	87	187	121	64	243	340	86	707	436	284	180	236
AMBIENT												
RELATED												
PROJECT												
TOTAL	87	187	121	64	243	340	86	707	436	284	180	236
LANE	2	1	1	2	1	1	2	3	2	2	3	2
SIGNAL	Prot-Fix	Auto	Prot-Fix	Auto	Prot-Fix	OLA	Prot-Fix	OLA	Prot-Fix	OLA	Prot-Fix	OLA

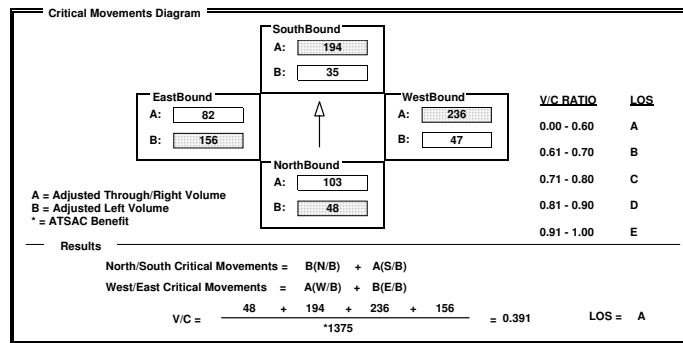

INTERSECTION DATA SUMMARY SHEET

N/S: W/E: I/S No:

AM/PM: Comments:

COUNT DATE: STUDY DATE: GROWTH FACTOR:

	NORTHBOUND			SOUTHBOUND			WESTBOUND			EASTBOUND		
	LT	TH	RT	LT	TH	RT	LT	TH	RT	LT	TH	RT
EXISTING	132	1660	682	273	2057	26	195	325	251	216	267	175
AMBIENT												
RELATED												
PROJECT												
TOTAL	132	1660	682	273	2057	26	195	325	251	216	267	175
LANE	1	3	1	2	3	1	2	3	1	2	3	1
Phasing	Prot-Fix		Auto	Prot-Fix		Auto	Prot-Fix		Auto	Prot-Fix		Auto
SIGNAL	Prot-Fix		Auto	Prot-Fix		Auto	Prot-Fix		Auto	Prot-Fix		Auto

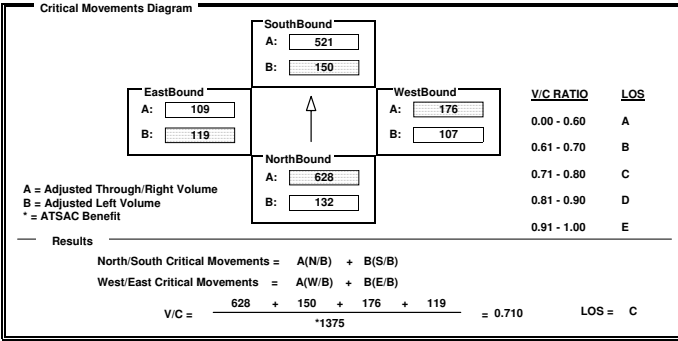

INTERSECTION DATA SUMMARY SHEET

N/S: W/E: I/S No:

AM/PM: Comments:

COUNT DATE: STUDY DATE: GROWTH FACTOR:

	NORTHBOUND			SOUTHBOUND			WESTBOUND			EASTBOUND		
	LT	TH	RT	LT	TH	RT	LT	TH	RT	LT	TH	RT
EXISTING	15	0	20	335	1090	517	245	807	0	0	534	91
AMBIENT												
RELATED												
PROJECT												
TOTAL	15	0	20	335	1090	517	245	807	0	0	534	91
LANE	1			2	1	1	2	3			2	1
Phasing	Split		Auto	Split		Auto	Prot-Fix		Auto	Perm		Auto
SIGNAL	Split		Auto	Split		Auto	Prot-Fix		Auto	Perm		Auto

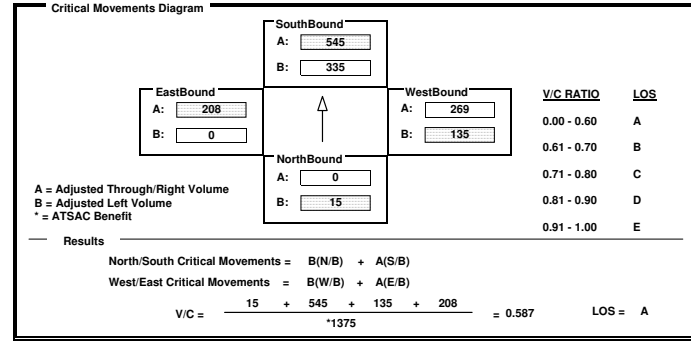

INTERSECTION DATA SUMMARY SHEET

N/S: W/E: I/S No:

AM/PM: Comments:

COUNT DATE: STUDY DATE: GROWTH FACTOR:

	NORTHBOUND			SOUTHBOUND			WESTBOUND			EASTBOUND		
	LT	TH	RT	LT	TH	RT	LT	TH	RT	LT	TH	RT
EXISTING	1068	0	390	0	0	0	100	967	0	0	341	532
AMBIENT												
RELATED												
PROJECT												
TOTAL	1068	0	390	0	0	0	100	967	0	0	341	532
LANE	2		2				2	2		2	1	1
Phasing	Split		OLA	<none>		<none>	Prot-Fix		Auto	Perm		OLA
SIGNAL	Split		OLA	<none>		<none>	Prot-Fix		Auto	Perm		OLA

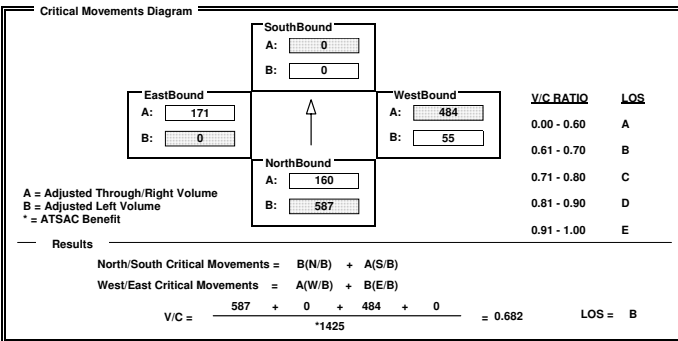

INTERSECTION DATA SUMMARY SHEET

N/S: W/E: I/S No:

AM/PM: Comments:

COUNT DATE: STUDY DATE: GROWTH FACTOR:

	NORTHBOUND			SOUTHBOUND			WESTBOUND			EASTBOUND		
	LT	TH	RT	LT	TH	RT	LT	TH	RT	LT	TH	RT
EXISTING	16	1576	412	207	1303	203	327	100	425	201	298	16
AMBIENT												
RELATED												
PROJECT												
TOTAL	16	1576	412	207	1303	203	327	100	425	201	298	16
LANE	1	2	1	2	2	1	2	2	2	1	1	1
Phasing	Prot-Fix		OLA	Prot-Fix		OLA	Prot-Fix		OLA	Prot-Fix		Auto
SIGNAL	Prot-Fix		OLA	Prot-Fix		OLA	Prot-Fix		OLA	Prot-Fix		Auto

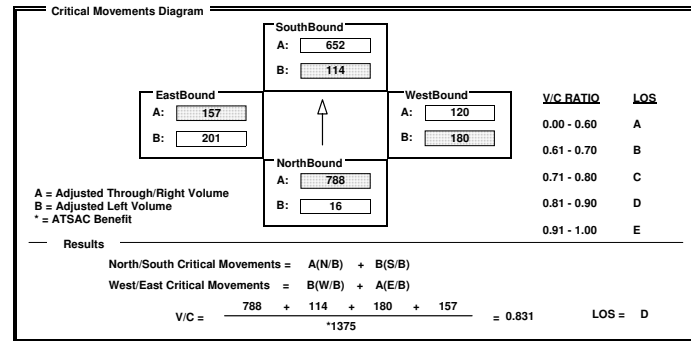

INTERSECTION DATA SUMMARY SHEET

N/S: W/E: I/S No:

AM/PM: Comments:

COUNT DATE: STUDY DATE: GROWTH FACTOR:

	NORTHBOUND			SOUTHBOUND			WESTBOUND			EASTBOUND		
	LT	TH	RT	LT	TH	RT	LT	TH	RT	LT	TH	RT
EXISTING	0	2629	58	0	2250	1120	0	0	0	743	173	0
AMBIENT												
RELATED												
PROJECT												
TOTAL	0	2629	58	0	2250	1120	0	0	0	743	173	0
LANE	1 2 1			1 2 1			1 2 1			3 1 1		
SIGNAL	Phasing		RTOR	Phasing		RTOR	Phasing		RTOR	Phasing		RTOR
	Perm		Auto	Perm		OLA	<none>		<none>	Split		Auto

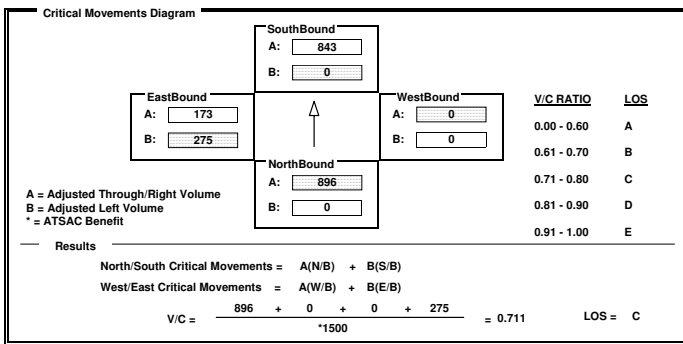

INTERSECTION DATA SUMMARY SHEET

N/S: W/E: I/S No:

AM/PM: Comments:

COUNT DATE: STUDY DATE: GROWTH FACTOR:

	NORTHBOUND			SOUTHBOUND			WESTBOUND			EASTBOUND		
	LT	TH	RT	LT	TH	RT	LT	TH	RT	LT	TH	RT
EXISTING	48	1293	17	15	1239	25	9	7	16	33	13	36
AMBIENT												
RELATED												
PROJECT												
TOTAL	48	1293	17	15	1239	25	9	7	16	33	13	36
LANE	1 2 1			1 2 1			1 1 1			1 1 1		
SIGNAL	Phasing		RTOR	Phasing		RTOR	Phasing		RTOR	Phasing		RTOR
	Prot-Fix		Auto	Prot-Fix		Auto	Perm		Auto	Perm		OLA

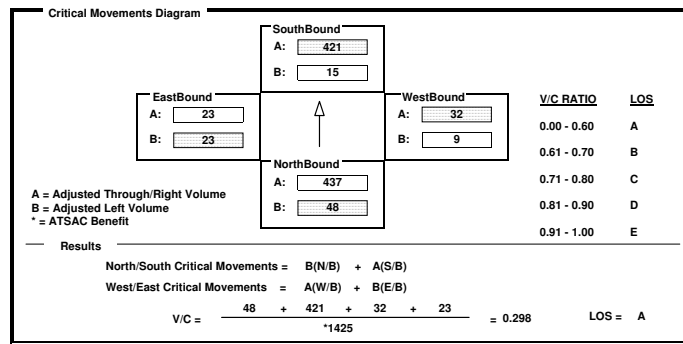

INTERSECTION DATA SUMMARY SHEET

N/S: W/E: I/S No:

AM/PM: Comments:

COUNT DATE: STUDY DATE: GROWTH FACTOR:

	NORTHBOUND			SOUTHBOUND			WESTBOUND			EASTBOUND		
	LT	TH	RT	LT	TH	RT	LT	TH	RT	LT	TH	RT
EXISTING	19	366	104	15	376	243	98	1108	27	136	533	12
AMBIENT												
RELATED												
PROJECT												
TOTAL	19	366	104	15	376	243	98	1108	27	136	533	12
LANE	1 2 1			1 2 1			1 2 1			1 2 1		
SIGNAL	Phasing		RTOR	Phasing		RTOR	Phasing		RTOR	Phasing		RTOR
	Perm		Auto	Perm		Auto	Prot-Fix		Auto	Prot-Fix		Free

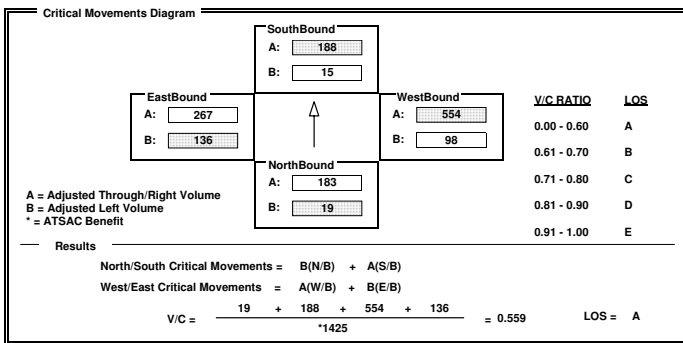

INTERSECTION DATA SUMMARY SHEET

N/S: W/E: I/S No:

AM/PM: Comments:

COUNT DATE: STUDY DATE: GROWTH FACTOR:

	NORTHBOUND			SOUTHBOUND			WESTBOUND			EASTBOUND		
	LT	TH	RT	LT	TH	RT	LT	TH	RT	LT	TH	RT
EXISTING	94	1365	101	45	1081	54	200	193	32	43	313	77
AMBIENT												
RELATED												
PROJECT												
TOTAL	94	1365	101	45	1081	54	200	193	32	43	313	77
LANE	1 3 1			1 3 1			1 2 1			1 2 1		
SIGNAL	Phasing		RTOR	Phasing		RTOR	Phasing		RTOR	Phasing		RTOR
	Perm		Auto	Perm		Auto	Perm		Auto	Perm		Auto

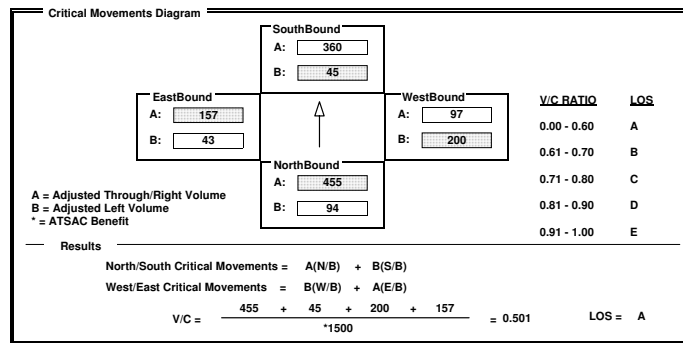

INTERSECTION DATA SUMMARY SHEET

N/S: W/E: I/S No:

AM/PM: Comments:

COUNT DATE: STUDY DATE: GROWTH FACTOR:

	NORTHBOUND			SOUTHBOUND			WESTBOUND			EASTBOUND		
	LT	TH	RT	LT	TH	RT	LT	TH	RT	LT	TH	RT
EXISTING	104	0	175	0	0	0	0	1156	331	447	725	0
AMBIENT												
RELATED												
PROJECT												
TOTAL	104	0	175	0	0	0	0	1156	331	447	725	0
LANE	1 1 1			1 1 1			3 1 1			1 3 1		
SIGNAL	Phasing		RTOR	Phasing		RTOR	Phasing		RTOR	Phasing		RTOR
	Split		Auto	<none>		<none>	Perm		Auto	Prot-Fix		<none>

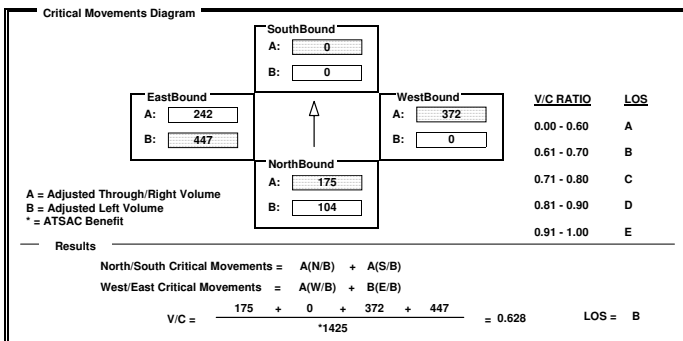

INTERSECTION DATA SUMMARY SHEET

N/S: W/E: I/S No:

AM/PM: Comments:

COUNT DATE: STUDY DATE: GROWTH FACTOR:

	NORTHBOUND			SOUTHBOUND			WESTBOUND			EASTBOUND		
	LT	TH	RT	LT	TH	RT	LT	TH	RT	LT	TH	RT
EXISTING	0	0	0	81	0	346	323	937	0	0	1091	212
AMBIENT												
RELATED												
PROJECT												
TOTAL	0	0	0	81	0	346	323	937	0	0	1091	212
LANE	1 1 1			1 1 1			1 3 1			1 3 1		
SIGNAL	Phasing		RTOR	Phasing		RTOR	Phasing		RTOR	Phasing		RTOR
	<none>		<none>	Split		<none>	Prot-Fix		<none>	Perm		Auto

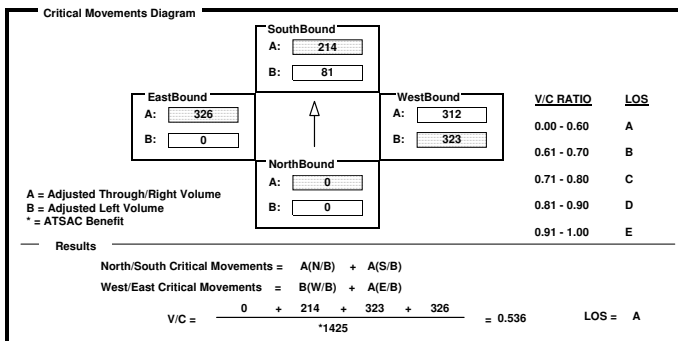

INTERSECTION DATA SUMMARY SHEET

N/S: W/E: I/S No:

AM/PM: Comments:

COUNT DATE: STUDY DATE: GROWTH FACTOR:

	NORTHBOUND			SOUTHBOUND			WESTBOUND			EASTBOUND		
	LT	TH	RT	LT	TH	RT	LT	TH	RT	LT	TH	RT
EXISTING	17	1933	208	161	1467	18	31	0	55	16	18	22
AMBIENT												
RELATED												
PROJECT												
TOTAL	17	1933	208	161	1467	18	31	0	55	16	18	22
LANE	1 2 1			2 2 1			1 1 1			1 1 1		
SIGNAL	Phasing		RTOR	Phasing		RTOR	Phasing		RTOR	Phasing		RTOR
	Prot-Fix		Auto	Prot-Fix		Auto	Perm		Auto	Perm		Auto

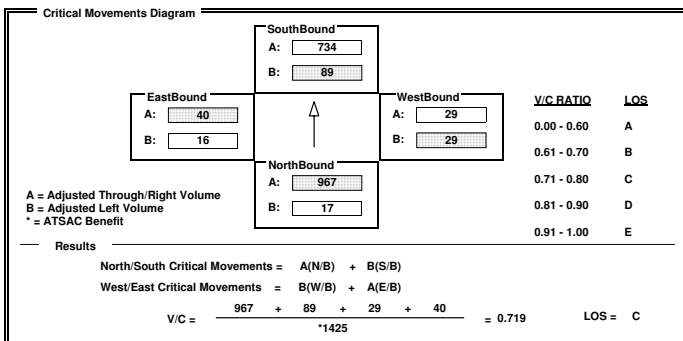

INTERSECTION DATA SUMMARY SHEET

N/S: W/E: I/S No:

AM/PM: Comments:

COUNT DATE: STUDY DATE: GROWTH FACTOR:

	NORTHBOUND			SOUTHBOUND			WESTBOUND			EASTBOUND		
	LT	TH	RT	LT	TH	RT	LT	TH	RT	LT	TH	RT
EXISTING	43	1173	103	138	1170	39	128	268	302	101	299	70
AMBIENT												
RELATED												
PROJECT												
TOTAL	43	1173	103	138	1170	39	128	268	302	101	299	70
LANE	1 2 1			1 2 1			1 2 1			1 2 1		
SIGNAL	Phasing		RTOR	Phasing		RTOR	Phasing		RTOR	Phasing		RTOR
	Prot-Fix		Auto	Prot-Fix		Auto	Prot-Fix		OLA	Prot-Fix		Auto

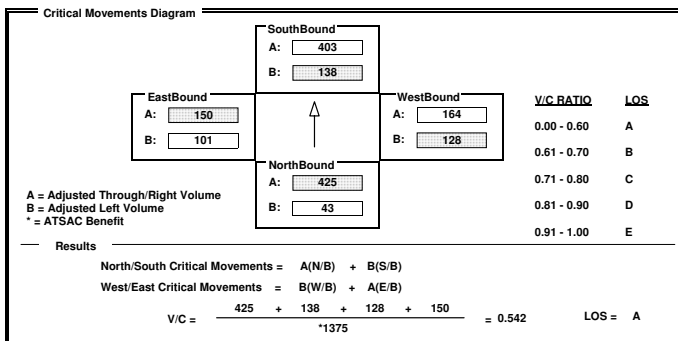

INTERSECTION DATA SUMMARY SHEET

N/S: Lincoln Blvd W/E: Marina Pointe Dr/ Maxella Ave I/S No: 106
 AM/PM: AM Comments: Existing
 COUNT DATE: STUDY DATE: GROWTH FACTOR:

	NORTHBOUND			SOUTHBOUND			WESTBOUND			EASTBOUND		
	LT	TH	RT	LT	TH	RT	LT	TH	RT	LT	TH	RT
EXISTING	162	1858	225	151	1617	38	259	76	188	142	88	101
AMBIENT												
RELATED												
PROJECT												
TOTAL	162	1858	225	151	1617	38	259	76	188	142	88	101
LANE	2	3	1	2	3	1	1	1	1	1	1	1
SIGNAL	Prot-Fix	OLA	Prot-Fix	Auto	Perm	OLA	Perm	OLA				

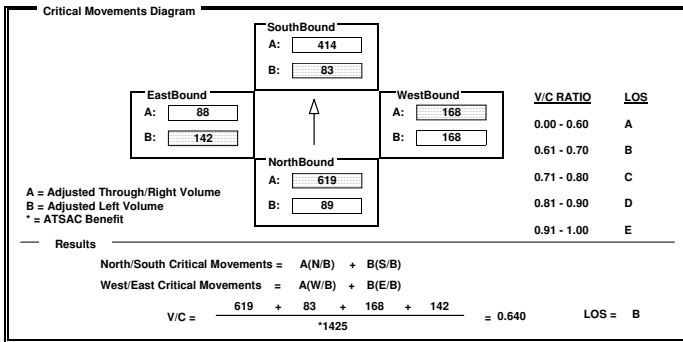

INTERSECTION DATA SUMMARY SHEET

N/S: Lincoln Blvd W/E: Mindanao Way I/S No: 107
 AM/PM: AM Comments: Existing
 COUNT DATE: STUDY DATE: GROWTH FACTOR:

	NORTHBOUND			SOUTHBOUND			WESTBOUND			EASTBOUND		
	LT	TH	RT	LT	TH	RT	LT	TH	RT	LT	TH	RT
EXISTING	118	1425	240	96	1078	49	240	432	115	1	422	32
AMBIENT												
RELATED												
PROJECT												
TOTAL	118	1425	240	96	1078	49	240	432	115	1	422	32
LANE	1	3	1	1	2	1	2	1	1	1	1	1
SIGNAL	Prot-Fix	Auto	Prot-Fix	Auto	Prot-Fix	Auto	Prot-Fix	Auto	Perm	Auto		

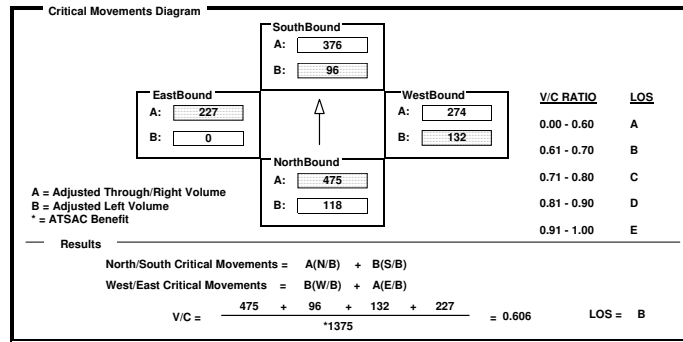

INTERSECTION DATA SUMMARY SHEET

N/S: Sepulveda Blvd W/E: Lincoln Blvd I/S No: 108
 AM/PM: AM Comments: Existing
 COUNT DATE: STUDY DATE: GROWTH FACTOR:

	NORTHBOUND			SOUTHBOUND			WESTBOUND			EASTBOUND		
	LT	TH	RT	LT	TH	RT	LT	TH	RT	LT	TH	RT
EXISTING	1160	1678	386	0	1390	4	0	0	3	0	0	1069
AMBIENT												
RELATED												
PROJECT												
TOTAL	1160	1678	386	0	1390	4	0	0	3	0	0	1069
LANE	3	2	1	3	1				1			4
SIGNAL	Prot-Fix	Auto	<none>	Auto	<none>	Auto	<none>	Auto	<none>	Auto		

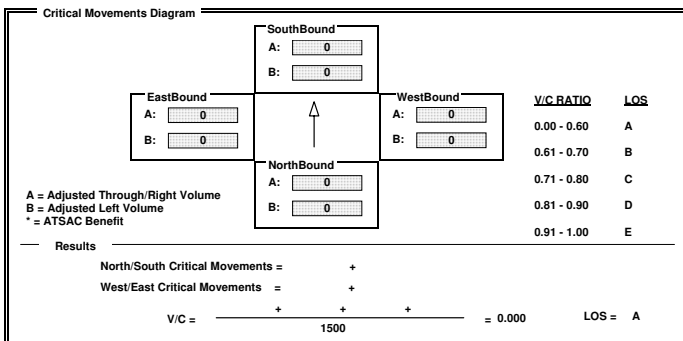

INTERSECTION DATA SUMMARY SHEET

N/S: Lincoln Blvd W/E: Venice Blvd I/S No: 109
 AM/PM: AM Comments: Existing
 COUNT DATE: STUDY DATE: GROWTH FACTOR:

	NORTHBOUND			SOUTHBOUND			WESTBOUND			EASTBOUND		
	LT	TH	RT	LT	TH	RT	LT	TH	RT	LT	TH	RT
EXISTING	137	1633	154	147	1269	38	262	540	263	112	792	119
AMBIENT												
RELATED												
PROJECT												
TOTAL	137	1633	154	147	1269	38	262	540	263	112	792	119
LANE	2	2	1	2	2	1	2	2	1	2	3	1
SIGNAL	Prot-Fix	Auto	Prot-Fix	Auto	Prot-Fix	OLA	Prot-Fix	OLA				

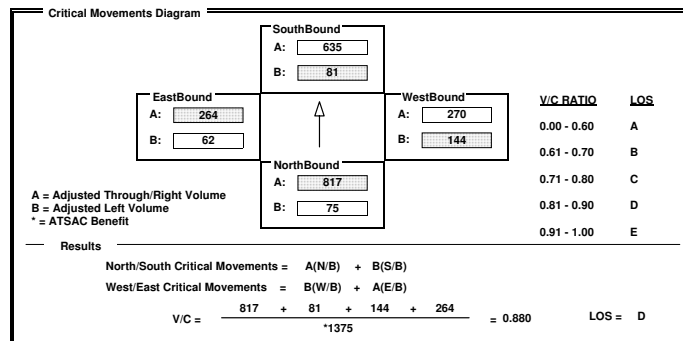

INTERSECTION DATA SUMMARY SHEET

N/S: W/E: I/S No:

AM/PM: Comments:

COUNT DATE: STUDY DATE: GROWTH FACTOR:

	NORTHBOUND			SOUTHBOUND			WESTBOUND			EASTBOUND		
	LT	TH	RT	LT	TH	RT	LT	TH	RT	LT	TH	RT
EXISTING	375	1617	149	215	1506	152	154	648	224	137	689	193
AMBIENT												
RELATED												
PROJECT												
TOTAL	375	1617	149	215	1506	152	154	648	224	137	689	193
LANE	2	2	1	2	2	1	2	2	1	2	2	1
SIGNAL	Prot-Fix		Auto	Prot-Fix		Auto	Prot-Fix		OLA	Prot-Fix		OLA

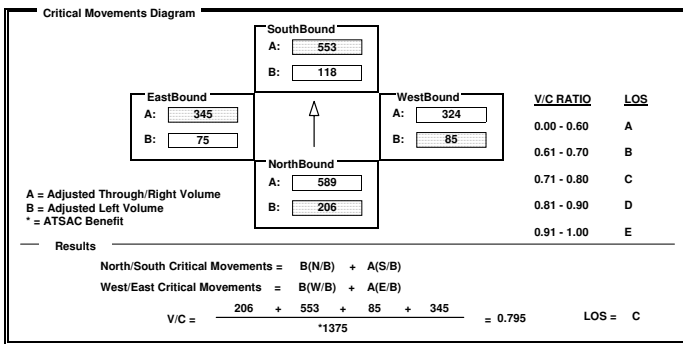

INTERSECTION DATA SUMMARY SHEET

N/S: W/E: I/S No:

AM/PM: Comments:

COUNT DATE: STUDY DATE: GROWTH FACTOR:

	NORTHBOUND			SOUTHBOUND			WESTBOUND			EASTBOUND		
	LT	TH	RT	LT	TH	RT	LT	TH	RT	LT	TH	RT
EXISTING	6	1745	9	103	1191	68	24	28	206	31	62	352
AMBIENT												
RELATED												
PROJECT												
TOTAL	6	1745	9	103	1191	68	24	28	206	31	62	352
LANE	1	2	1	1	2	1	1	1	1	1	1	1
SIGNAL	Perm		Auto	Prot-Fix		Auto	Perm		OLA	Prot-Fix		Auto

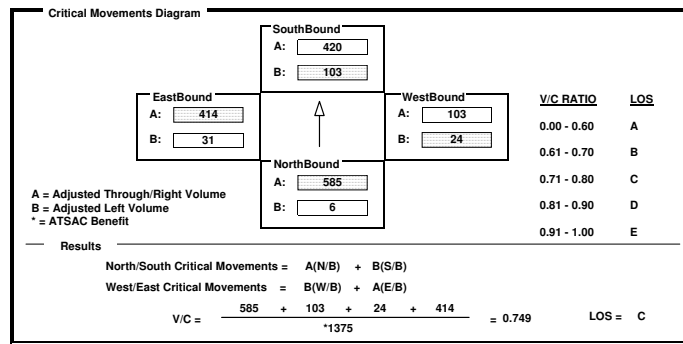

INTERSECTION DATA SUMMARY SHEET

N/S: W/E: I/S No:

AM/PM: Comments:

COUNT DATE: STUDY DATE: GROWTH FACTOR:

	NORTHBOUND			SOUTHBOUND			WESTBOUND			EASTBOUND		
	LT	TH	RT	LT	TH	RT	LT	TH	RT	LT	TH	RT
EXISTING	104	1388	47	141	962	101	84	867	364	131	518	70
AMBIENT												
RELATED												
PROJECT												
TOTAL	104	1388	47	141	962	101	84	867	364	131	518	70
LANE	1	3	1	1	3	1	1	2	1	2	2	1
SIGNAL	Prot-Fix		Auto	Prot-Fix		Auto	Prot-Fix		Auto	Prot-Fix		Auto

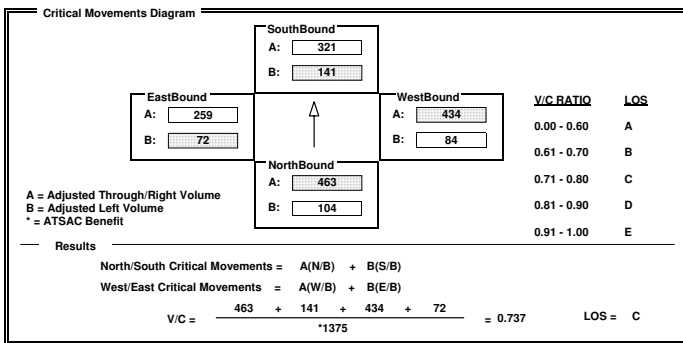

INTERSECTION DATA SUMMARY SHEET

N/S: W/E: I/S No:

AM/PM: Comments:

COUNT DATE: STUDY DATE: GROWTH FACTOR:

	NORTHBOUND			SOUTHBOUND			WESTBOUND			EASTBOUND		
	LT	TH	RT	LT	TH	RT	LT	TH	RT	LT	TH	RT
EXISTING	151	1433	46	91	1126	41	111	251	99	13	180	59
AMBIENT												
RELATED												
PROJECT												
TOTAL	151	1433	46	91	1126	41	111	251	99	13	180	59
LANE	1	2	1	1	2	1	1	1	1	1	2	1
SIGNAL	Prot-Fix		Auto	Prot-Fix		Auto	Prot-Fix		Auto	Prot-Fix		Auto

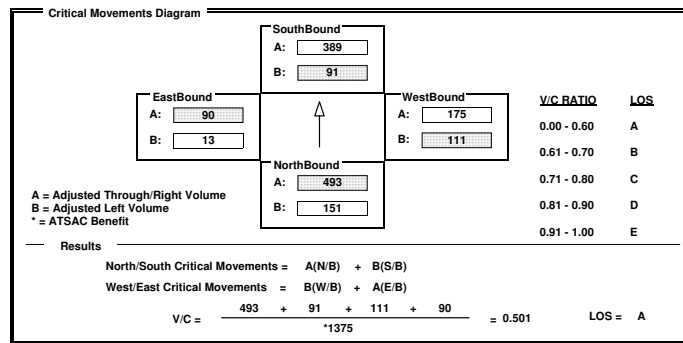

INTERSECTION DATA SUMMARY SHEET

N/S: W/E: I/S No:

AM/PM: Comments:

COUNT DATE: STUDY DATE: GROWTH FACTOR:

Volume/Lane/Signal Configurations

	NORTHBOUND			SOUTHBOUND			WESTBOUND			EASTBOUND		
	LT	TH	RT	LT	TH	RT	LT	TH	RT	LT	TH	RT
EXISTING	37	1932	11	42	1182	118	26	63	240	590	37	50
AMBIENT												
RELATED												
PROJECT												
TOTAL	37	1932	11	42	1182	118	26	63	240	590	37	50
LANE	1	3	1	1	2	1	1	1	1	2	1	1
Phasing	Perm		Auto	Perm		Auto	Perm		Auto	Perm		Auto
SIGNAL	Perm		Auto	Perm		Auto	Perm		Auto	Perm		Auto

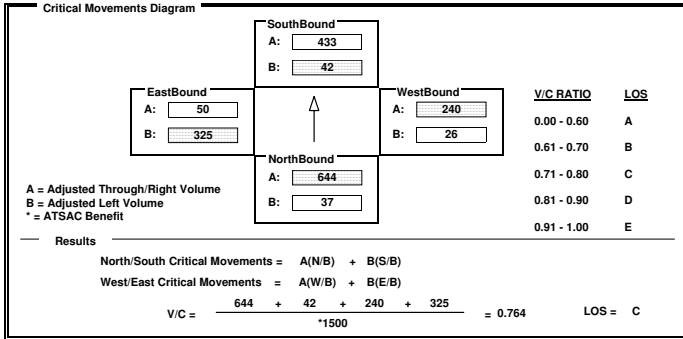

INTERSECTION DATA SUMMARY SHEET

N/S: W/E: I/S No:

AM/PM: Comments:

COUNT DATE: STUDY DATE: GROWTH FACTOR:

Volume/Lane/Signal Configurations

	NORTHBOUND			SOUTHBOUND			WESTBOUND			EASTBOUND		
	LT	TH	RT	LT	TH	RT	LT	TH	RT	LT	TH	RT
EXISTING	83	1877	11	30	995	116	17	177	104	136	85	75
AMBIENT												
RELATED												
PROJECT												
TOTAL	83	1877	11	30	995	116	17	177	104	136	85	75
LANE	1	2	1	1	3	1	1	1	1	1	1	1
Phasing	Perm		Auto	Perm		Auto	Perm		Auto	Perm		Auto
SIGNAL	Perm		Auto	Perm		Auto	Perm		Auto	Perm		Auto

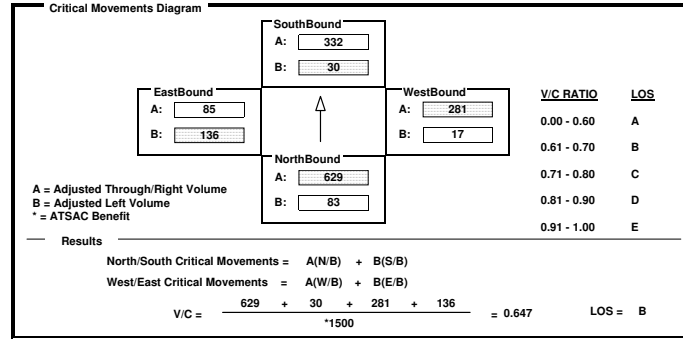

INTERSECTION DATA SUMMARY SHEET

N/S: W/E: I/S No:

AM/PM: Comments:

COUNT DATE: STUDY DATE: GROWTH FACTOR:

Volume/Lane/Signal Configurations

	NORTHBOUND			SOUTHBOUND			WESTBOUND			EASTBOUND		
	LT	TH	RT	LT	TH	RT	LT	TH	RT	LT	TH	RT
EXISTING	27	1792	5	24	1076	44	5	72	38	62	89	42
AMBIENT												
RELATED												
PROJECT												
TOTAL	27	1792	5	24	1076	44	5	72	38	62	89	42
LANE	1	2	1	1	2	1	1	1	1	1	1	1
Phasing	Perm		Auto	Perm		Auto	Perm		Auto	Perm		Auto
SIGNAL	Perm		Auto	Perm		Auto	Perm		Auto	Perm		Auto

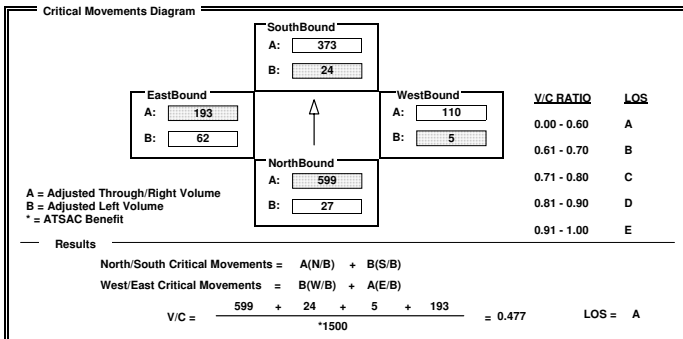

INTERSECTION DATA SUMMARY SHEET

N/S: W/E: I/S No:

AM/PM: Comments:

COUNT DATE: STUDY DATE: GROWTH FACTOR:

Volume/Lane/Signal Configurations

	NORTHBOUND			SOUTHBOUND			WESTBOUND			EASTBOUND		
	LT	TH	RT	LT	TH	RT	LT	TH	RT	LT	TH	RT
EXISTING	0	2127	0	0	0	0	0	0	1988	0	0	0
AMBIENT												
RELATED												
PROJECT												
TOTAL	0	2127	0	0	0	0	0	0	1988	0	0	0
LANE	3			0					3			0
Phasing	Split		<none>	<none>		<none>	Split		<none>	<none>		<none>
SIGNAL	Split		<none>	<none>		<none>	Split		<none>	<none>		<none>

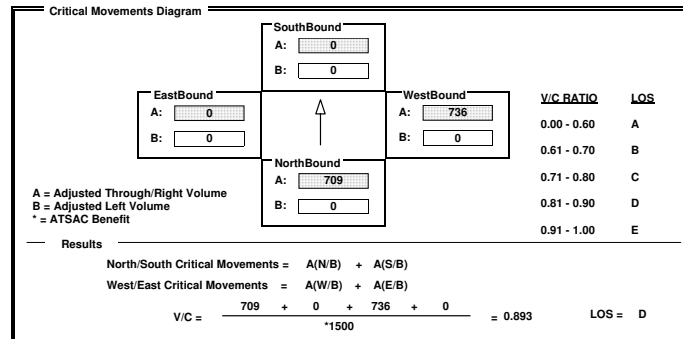

INTERSECTION DATA SUMMARY SHEET

N/S: Airport Blvd W/E: 96th St I/S No: 141
AM/PM: AM Comments: Existing
COUNT DATE: STUDY DATE: GROWTH FACTOR:

Volume/Lane/Signal Configurations table with columns for Northbound, Southbound, Westbound, Eastbound and rows for Existing, Ambient, Related, Project, Total, Lane, Phasing, RTOR, Signal.

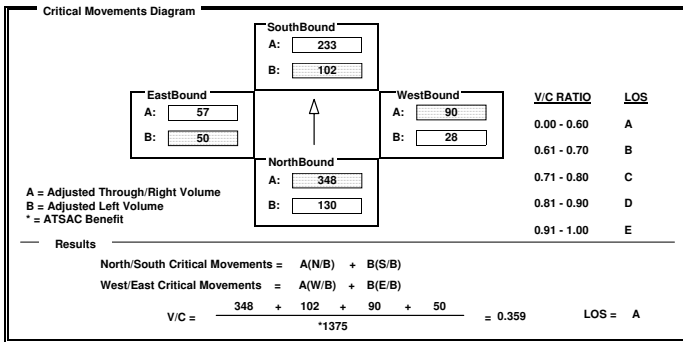

INTERSECTION DATA SUMMARY SHEET

N/S: Airport Blvd W/E: 98 St I/S No: 144
AM/PM: AM Comments: Existing
COUNT DATE: STUDY DATE: GROWTH FACTOR:

Volume/Lane/Signal Configurations table with columns for Northbound, Southbound, Westbound, Eastbound and rows for Existing, Ambient, Related, Project, Total, Lane, Phasing, RTOR, Signal.

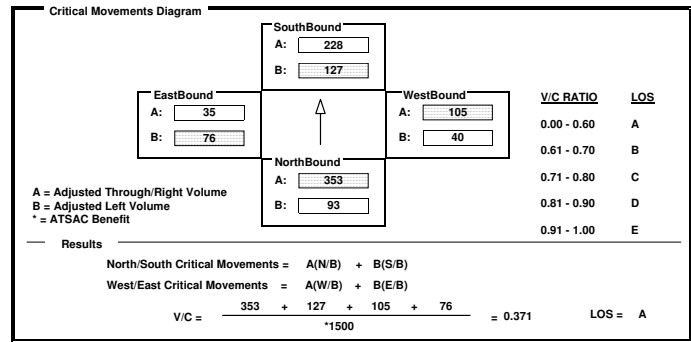

INTERSECTION DATA SUMMARY SHEET

N/S: Sepulveda Eastway W/E: Westchester Pkwy I/S No: 146
AM/PM: AM Comments: Existing
COUNT DATE: STUDY DATE: GROWTH FACTOR:

Volume/Lane/Signal Configurations table with columns for Northbound, Southbound, Westbound, Eastbound and rows for Existing, Ambient, Related, Project, Total, Lane, Phasing, RTOR, Signal.

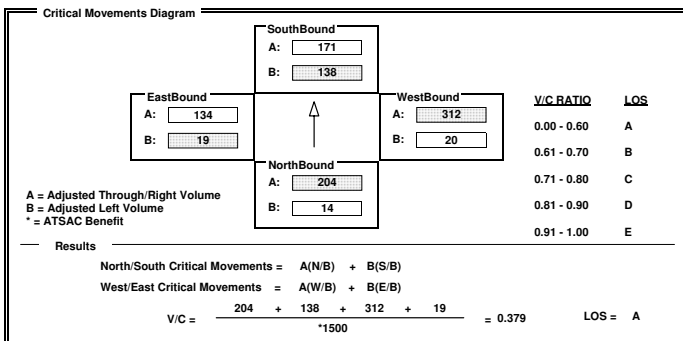

INTERSECTION DATA SUMMARY SHEET

N/S: La Cienega Blvd W/E: I-405 SB Ramps N/O Century I/S No: 96
AM/PM: AM Comments: Existing
COUNT DATE: STUDY DATE: GROWTH FACTOR:

Volume/Lane/Signal Configurations table with columns for Northbound, Southbound, Westbound, Eastbound and rows for Existing, Ambient, Related, Project, Total, Lane, Phasing, RTOR, Signal.

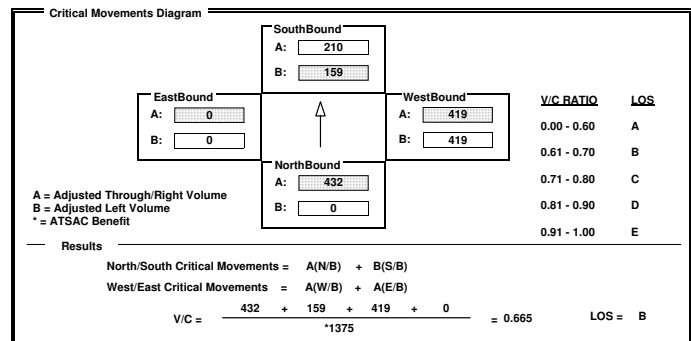

INTERSECTION DATA SUMMARY SHEET

N/S: La Cienega Blvd W/E: I-405 SB Ramps S/O Century I/S No: 97
 AM/PM: AM Comments: Existing
 COUNT DATE: STUDY DATE: GROWTH FACTOR:

	NORTHBOUND			SOUTHBOUND			WESTBOUND			EASTBOUND		
	LT	TH	RT	LT	TH	RT	LT	TH	RT	LT	TH	RT
EXISTING	0	584	32	494	605	0	0	0	158	0	0	0
AMBIENT												
RELATED												
PROJECT												
TOTAL	0	584	32	494	605	0	0	0	158	0	0	0
LANE	1 1			2 2			2			2		
SIGNAL	Phasing RTOR		Phasing RTOR		Phasing RTOR		Phasing RTOR		Phasing RTOR		Phasing RTOR	
	Perm Auto		Prot-Fix Auto		Split OLA		Split Auto					

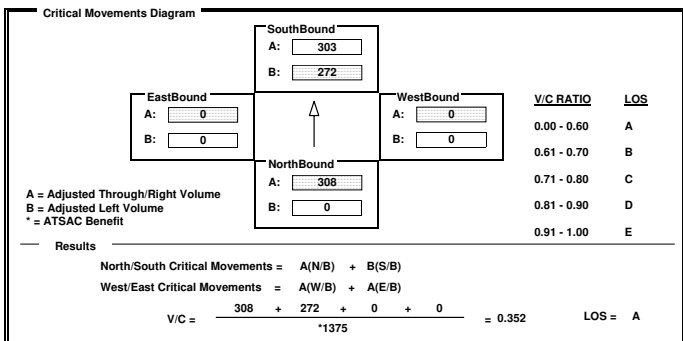

INTERSECTION DATA SUMMARY SHEET

N/S: La Cienega Blvd W/E: Centinela Blvd I/S No: 26
 AM/PM: AM Comments: Existing
 COUNT DATE: STUDY DATE: GROWTH FACTOR:

	NORTHBOUND			SOUTHBOUND			WESTBOUND			EASTBOUND		
	LT	TH	RT	LT	TH	RT	LT	TH	RT	LT	TH	RT
EXISTING	199	2461	41	93	2167	8	191	1214	180	0	418	124
AMBIENT												
RELATED												
PROJECT												
TOTAL	199	2461	41	93	2167	8	191	1214	180	0	418	124
LANE	2 2 1			1 2 1			1 2 1			2 1		
SIGNAL	Phasing RTOR		Phasing RTOR		Phasing RTOR		Phasing RTOR		Phasing RTOR		Phasing RTOR	
	Prot-Fix Auto		Prot-Fix Auto		Prot-Fix Auto		Prot-Fix Auto		Perm Auto			

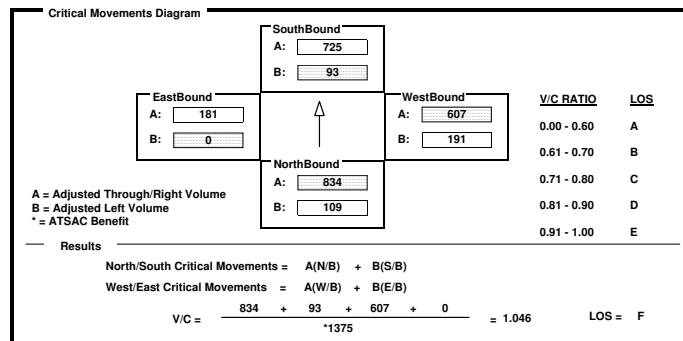

INTERSECTION DATA SUMMARY SHEET

N/S: Centinela Ave W/E: Venice Blvd I/S No: 29
 AM/PM: AM Comments: Existing
 COUNT DATE: STUDY DATE: GROWTH FACTOR:

	NORTHBOUND			SOUTHBOUND			WESTBOUND			EASTBOUND		
	LT	TH	RT	LT	TH	RT	LT	TH	RT	LT	TH	RT
EXISTING	79	1384	117	65	657	63	183	1009	162	238	1311	82
AMBIENT												
RELATED												
PROJECT												
TOTAL	79	1384	117	65	657	63	183	1009	162	238	1311	82
LANE	1 2 1			1 2 1			1 2 1			1 2 1		
SIGNAL	Phasing RTOR		Phasing RTOR		Phasing RTOR		Phasing RTOR		Phasing RTOR		Phasing RTOR	
	Perm Auto		Prot-Fix Auto		Prot-Fix Auto		Prot-Fix Auto		Prot-Fix Auto			

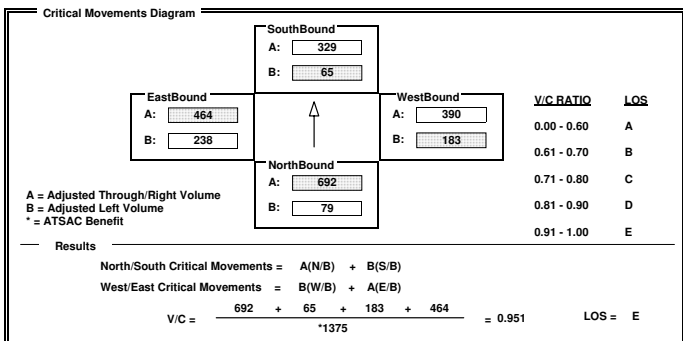

INTERSECTION DATA SUMMARY SHEET

N/S: La Brea Ave W/E: Manchester Ave I/S No: 85
 AM/PM: AM Comments: Existing
 COUNT DATE: STUDY DATE: GROWTH FACTOR:

	NORTHBOUND			SOUTHBOUND			WESTBOUND			EASTBOUND		
	LT	TH	RT	LT	TH	RT	LT	TH	RT	LT	TH	RT
EXISTING	87	687	13	99	454	99	27	968	138	155	454	61
AMBIENT												
RELATED												
PROJECT												
TOTAL	87	687	13	99	454	99	27	968	138	155	454	61
LANE	1 1 1			1 2 1			1 2 1			1 2 1		
SIGNAL	Phasing RTOR		Phasing RTOR		Phasing RTOR		Phasing RTOR		Phasing RTOR		Phasing RTOR	
	Prot-Fix Auto		Prot-Fix Auto		Prot-Fix Auto		Prot-Fix Auto		Prot-Fix Auto			

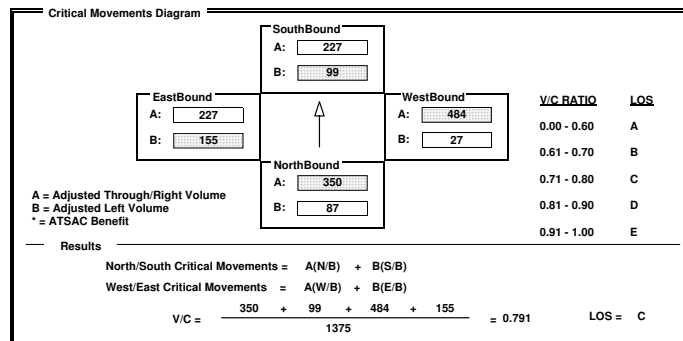

INTERSECTION DATA SUMMARY SHEET

N/S: La Cienega Blvd W/E: Stocker Ave I/S No: 93
AM/PM: AM Comments: Existing
COUNT DATE: STUDY DATE: GROWTH FACTOR:

Volume/Lane/Signal Configurations table with columns for Northbound, Southbound, Westbound, Eastbound and rows for Existing, Ambient, Related, Project, Total, Lane, and Signal.

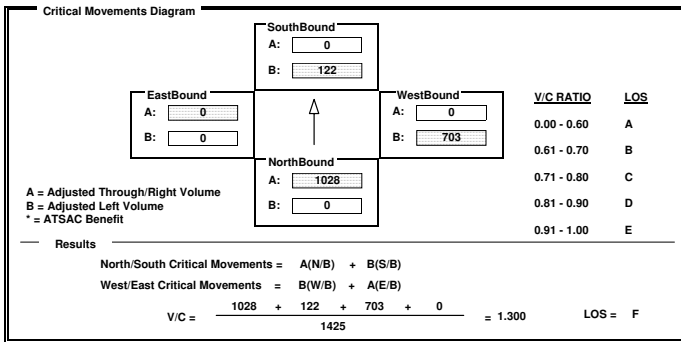

INTERSECTION DATA SUMMARY SHEET

N/S: Overland Ave W/E: Venice Blvd I/S No: 121
AM/PM: AM Comments: Existing
COUNT DATE: STUDY DATE: GROWTH FACTOR:

Volume/Lane/Signal Configurations table with columns for Northbound, Southbound, Westbound, Eastbound and rows for Existing, Ambient, Related, Project, Total, Lane, and Signal.

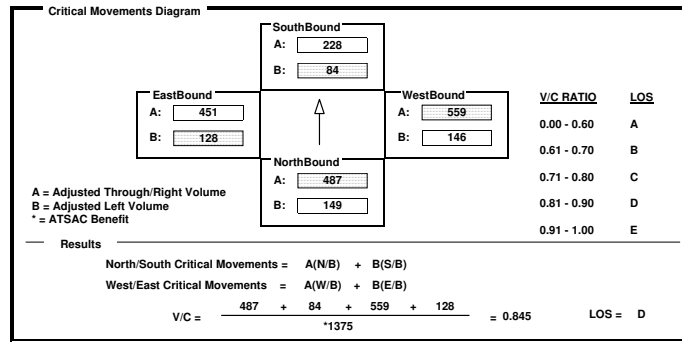

INTERSECTION DATA SUMMARY SHEET

N/S: Lincoln Blvd W/E: Rose Ave I/S No: 160
AM/PM: AM Comments: Existing
COUNT DATE: STUDY DATE: GROWTH FACTOR:

Volume/Lane/Signal Configurations table with columns for Northbound, Southbound, Westbound, Eastbound and rows for Existing, Ambient, Related, Project, Total, Lane, and Signal.

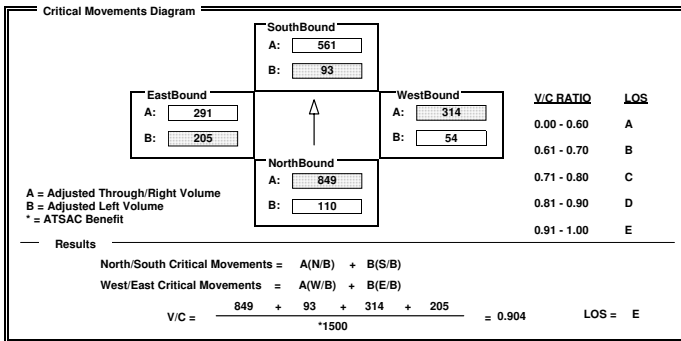

INTERSECTION DATA SUMMARY SHEET

N/S: Western Ave W/E: Century Blvd I/S No: 161
AM/PM: AM Comments: Existing
COUNT DATE: STUDY DATE: GROWTH FACTOR:

Volume/Lane/Signal Configurations table with columns for Northbound, Southbound, Westbound, Eastbound and rows for Existing, Ambient, Related, Project, Total, Lane, and Signal.

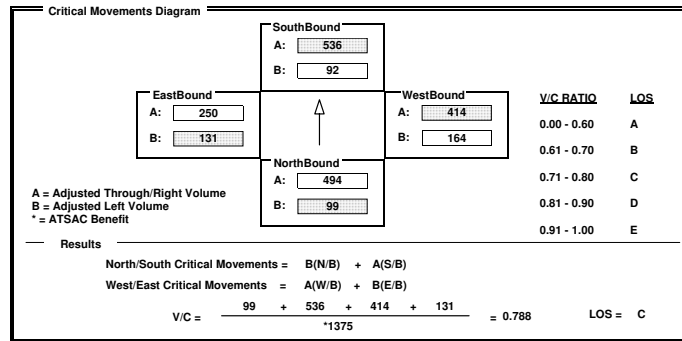

INTERSECTION DATA SUMMARY SHEET

N/S: W/E: I/S No:

AM/PM: Comments:

COUNT DATE: STUDY DATE: GROWTH FACTOR:

Volume/Lane/Signal Configurations

	NORTHBOUND			SOUTHBOUND			WESTBOUND			EASTBOUND		
	LT	TH	RT	LT	TH	RT	LT	TH	RT	LT	TH	RT
EXISTING	87	2409	94	50	2076	567	317	1167	119	440	565	117
AMBIENT												
RELATED												
PROJECT												
TOTAL	87	2409	94	50	2076	567	317	1167	119	440	565	117
LANE	1	2	1	1	3	1	2	2	1	2	1	1
SIGNAL	Phasing: <input type="text" value="Perm"/> RTOR: <input type="text" value="Auto"/>		Phasing: <input type="text" value="Perm"/> RTOR: <input type="text" value="OLA"/>		Phasing: <input type="text" value="Prot-Fix"/> RTOR: <input type="text" value="Auto"/>		Phasing: <input type="text" value="Prot-Fix"/> RTOR: <input type="text" value="Auto"/>					

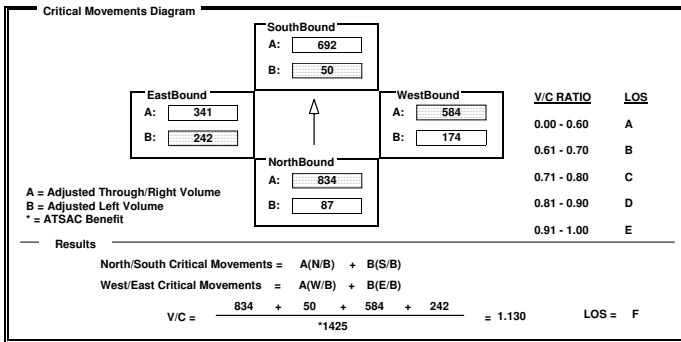

INTERSECTION DATA SUMMARY SHEET

N/S: W/E: I/S No:

AM/PM: Comments:

COUNT DATE: STUDY DATE: GROWTH FACTOR:

Volume/Lane/Signal Configurations

	NORTHBOUND			SOUTHBOUND			WESTBOUND			EASTBOUND		
	LT	TH	RT	LT	TH	RT	LT	TH	RT	LT	TH	RT
EXISTING	135	751	120	75	609	73	175	448	138	93	465	108
AMBIENT												
RELATED												
PROJECT												
TOTAL	135	751	120	75	609	73	175	448	138	93	465	108
LANE	1	2	1	1	3	1	1	1	1	1	2	1
SIGNAL	Phasing: <input type="text" value="Prot-Fix"/> RTOR: <input type="text" value="Auto"/>		Phasing: <input type="text" value="Prot-Fix"/> RTOR: <input type="text" value="Auto"/>		Phasing: <input type="text" value="Prot-Fix"/> RTOR: <input type="text" value="Auto"/>		Phasing: <input type="text" value="Prot-Fix"/> RTOR: <input type="text" value="Auto"/>					

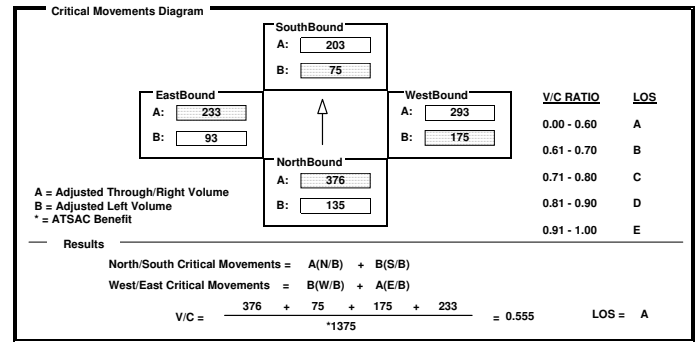

INTERSECTION DATA SUMMARY SHEET

N/S: W/E: I/S No:

AM/PM: Comments:

COUNT DATE: STUDY DATE: GROWTH FACTOR:

Volume/Lane/Signal Configurations

	NORTHBOUND			SOUTHBOUND			WESTBOUND			EASTBOUND		
	LT	TH	RT	LT	TH	RT	LT	TH	RT	LT	TH	RT
EXISTING	16	40	33	326	13	374	60	1539	356	543	1437	24
AMBIENT												
RELATED												
PROJECT												
TOTAL	16	40	33	326	13	374	60	1539	356	543	1437	24
LANE	1	2	1	2	1	1	1	4	1	2	4	1
SIGNAL	Phasing: <input type="text" value="Split"/> RTOR: <input type="text" value="Auto"/>		Phasing: <input type="text" value="Split"/> RTOR: <input type="text" value="Auto"/>		Phasing: <input type="text" value="Prot-Fix"/> RTOR: <input type="text" value="OLA"/>		Phasing: <input type="text" value="Prot-Fix"/> RTOR: <input type="text" value="Auto"/>					

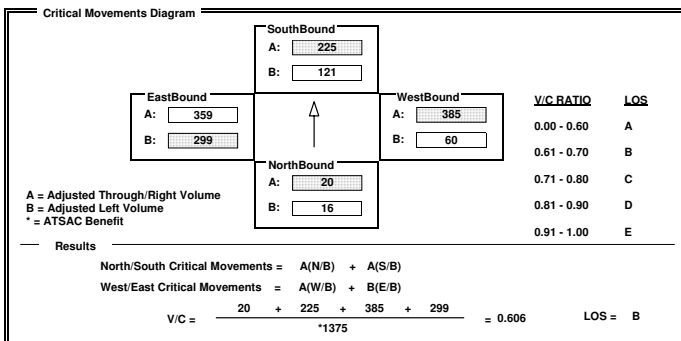

INTERSECTION DATA SUMMARY SHEET

N/S: W/E: I/S No:

AM/PM: Comments:

COUNT DATE: STUDY DATE: GROWTH FACTOR:

Volume/Lane/Signal Configurations

	NORTHBOUND			SOUTHBOUND			WESTBOUND			EASTBOUND		
	LT	TH	RT	LT	TH	RT	LT	TH	RT	LT	TH	RT
EXISTING	45	44	630	72	80	19	537	634	21	17	516	18
AMBIENT												
RELATED												
PROJECT												
TOTAL	45	44	630	72	80	19	537	634	21	17	516	18
LANE	1	2	1	1	1	1	2	1	1	1	2	1
SIGNAL	Phasing: <input type="text" value="Split"/> RTOR: <input type="text" value="OLA"/>		Phasing: <input type="text" value="Split"/> RTOR: <input type="text" value="Auto"/>		Phasing: <input type="text" value="Prot-Fix"/> RTOR: <input type="text" value="Auto"/>		Phasing: <input type="text" value="Prot-Fix"/> RTOR: <input type="text" value="Auto"/>					

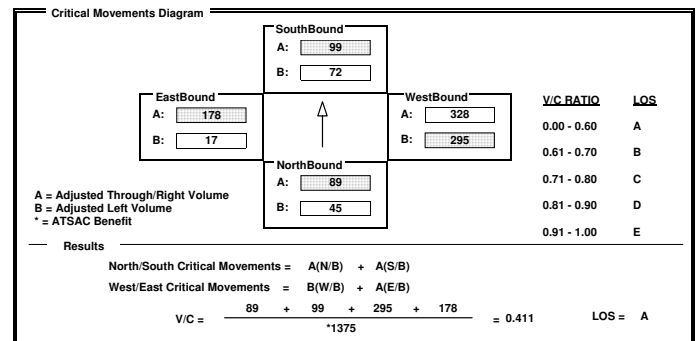

INTERSECTION DATA SUMMARY SHEET

N/S: Airport Blvd W/E: Manchester Ave I/S No: 9
AM/PM: MD Comments: Existing
COUNT DATE: STUDY DATE: GROWTH FACTOR:

Volume/Lane/Signal Configurations table with columns for Northbound, Southbound, Westbound, Eastbound and rows for Existing, Ambient, Related, Project, Total, Lane, Phasing, RTOR, Signal.

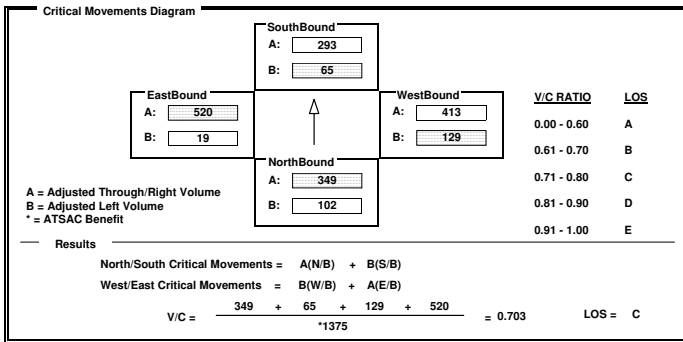

INTERSECTION DATA SUMMARY SHEET

N/S: Aviation Blvd W/E: Arbor Vitae St I/S No: 10
AM/PM: MD Comments: Existing
COUNT DATE: STUDY DATE: GROWTH FACTOR:

Volume/Lane/Signal Configurations table with columns for Northbound, Southbound, Westbound, Eastbound and rows for Existing, Ambient, Related, Project, Total, Lane, Phasing, RTOR, Signal.

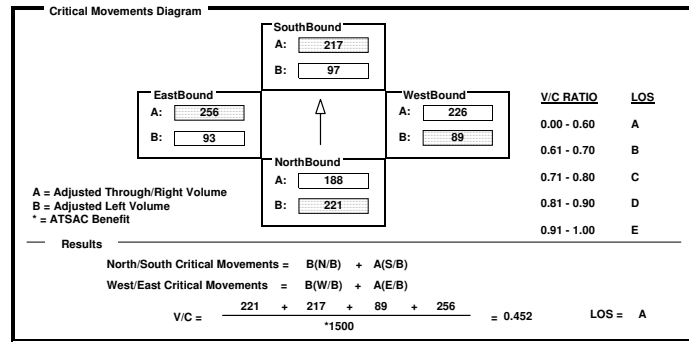

INTERSECTION DATA SUMMARY SHEET

N/S: Aviation Blvd W/E: Century Blvd I/S No: 14
AM/PM: MD Comments: Existing
COUNT DATE: STUDY DATE: GROWTH FACTOR:

Volume/Lane/Signal Configurations table with columns for Northbound, Southbound, Westbound, Eastbound and rows for Existing, Ambient, Related, Project, Total, Lane, Phasing, RTOR, Signal.

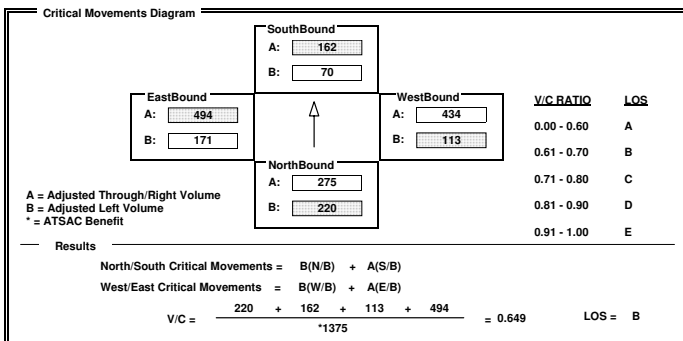

INTERSECTION DATA SUMMARY SHEET

N/S: Aviation Blvd W/E: Imperial Hwy I/S No: 16
AM/PM: MD Comments: Existing
COUNT DATE: STUDY DATE: GROWTH FACTOR:

Volume/Lane/Signal Configurations table with columns for Northbound, Southbound, Westbound, Eastbound and rows for Existing, Ambient, Related, Project, Total, Lane, Phasing, RTOR, Signal.

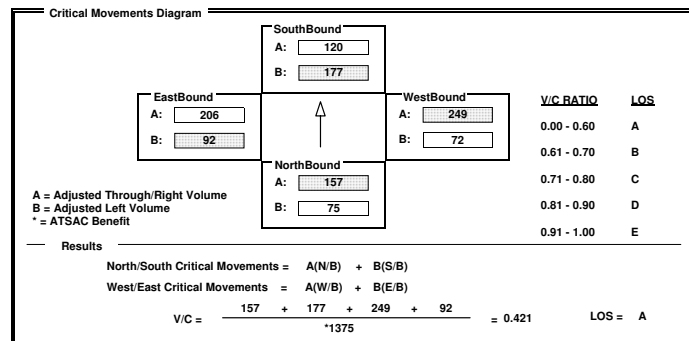

INTERSECTION DATA SUMMARY SHEET

N/S: Lincoln Blvd W/E: Bali Way I/S No: 21
 AM/PM: MD Comments: Existing
 COUNT DATE: STUDY DATE: GROWTH FACTOR:

	NORTHBOUND			SOUTHBOUND			WESTBOUND			EASTBOUND		
	LT	TH	RT	LT	TH	RT	LT	TH	RT	LT	TH	RT
EXISTING	93	1308	8	54	1194	250	1	0	18	268	2	50
AMBIENT												
RELATED												
PROJECT												
TOTAL	93	1308	8	54	1194	250	1	0	18	268	2	50
LANE	1 2 1			1 2 1			1			1 1 1		
SIGNAL	Prot-Fix		Auto	Prot-Fix		Auto	Prot-Fix		Auto	Prot-Fix		Auto

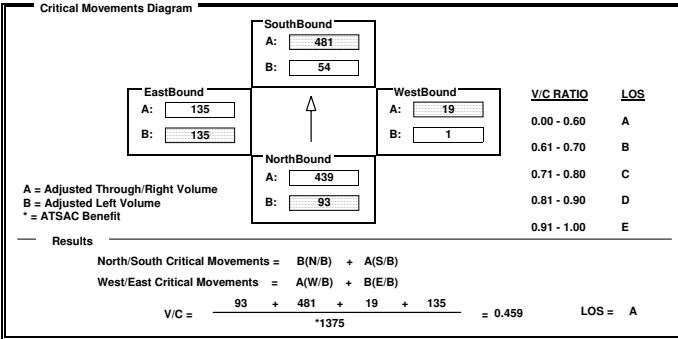

INTERSECTION DATA SUMMARY SHEET

N/S: Lincoln Blvd W/E: Bluff Creek Dr I/S No: 22
 AM/PM: MD Comments: Existing
 COUNT DATE: STUDY DATE: GROWTH FACTOR:

	NORTHBOUND			SOUTHBOUND			WESTBOUND			EASTBOUND		
	LT	TH	RT	LT	TH	RT	LT	TH	RT	LT	TH	RT
EXISTING	0	1562	0	0	1679	0	0	0	0	0	0	0
AMBIENT												
RELATED												
PROJECT												
TOTAL	0	1562	0	0	1679	0	0	0	0	0	0	0
LANE	2 1 1			2 1 1			2 1 1			2 1 1		
SIGNAL	<none>		Auto	<none>		Auto	<none>		Auto	<none>		Auto

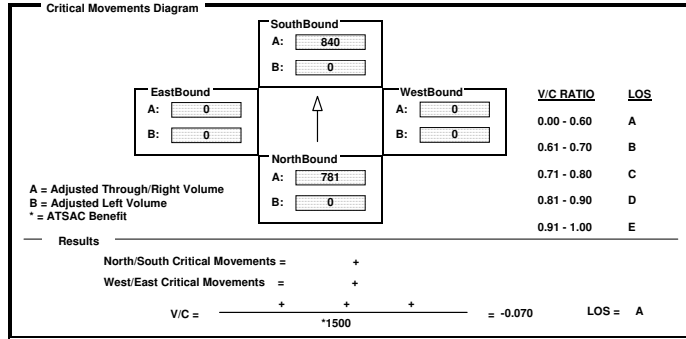

INTERSECTION DATA SUMMARY SHEET

N/S: La Tijera Blvd W/E: Centinela Ave I/S No: 27
 AM/PM: MD Comments: Existing
 COUNT DATE: STUDY DATE: GROWTH FACTOR:

	NORTHBOUND			SOUTHBOUND			WESTBOUND			EASTBOUND		
	LT	TH	RT	LT	TH	RT	LT	TH	RT	LT	TH	RT
EXISTING	186	758	174	83	757	100	194	677	18	119	569	99
AMBIENT												
RELATED												
PROJECT												
TOTAL	186	758	174	83	757	100	194	677	18	119	569	99
LANE	2 2 1			1 2 1			1 2 1			1 2 1		
SIGNAL	Prot-Fix		Auto	Prot-Fix		Auto	Prot-Fix		Auto	Prot-Fix		Auto

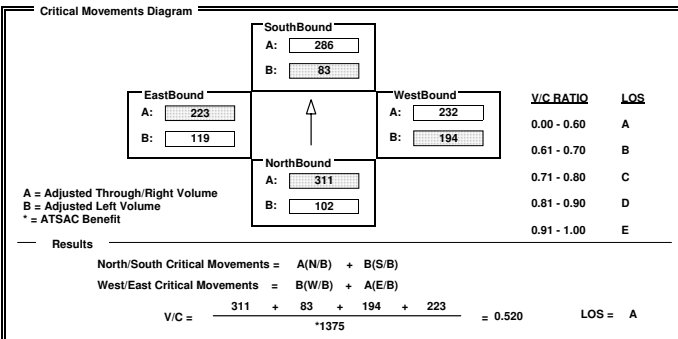

INTERSECTION DATA SUMMARY SHEET

N/S: La Cienega Blvd W/E: Century Blvd I/S No: 36
 AM/PM: MD Comments: Existing
 COUNT DATE: STUDY DATE: GROWTH FACTOR:

	NORTHBOUND			SOUTHBOUND			WESTBOUND			EASTBOUND		
	LT	TH	RT	LT	TH	RT	LT	TH	RT	LT	TH	RT
EXISTING	157	261	385	244	415	741	162	906	259	125	1180	562
AMBIENT												
RELATED												
PROJECT												
TOTAL	157	261	385	244	415	741	162	906	259	125	1180	562
LANE	1 2 2			1 2 2			1 3 1			1 3 1		
SIGNAL	Prot-Fix		OLA	Prot-Fix		OLA	Prot-Fix		Auto	Prot-Fix		OLA

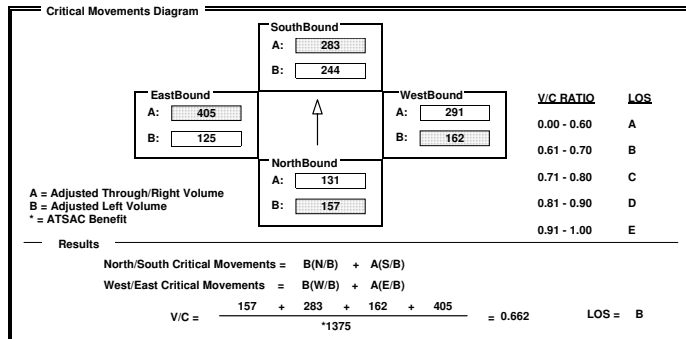

INTERSECTION DATA SUMMARY SHEET

N/S: Sepulveda Blvd W/E: Century Blvd I/S No: 38
AM/PM: MD Comments: Existing
COUNT DATE: STUDY DATE: GROWTH FACTOR:

Volume/Lane/Signal Configurations table with columns for Northbound, Southbound, Westbound, Eastbound and rows for Existing, Ambient, Related, Project, Total, Lane, and Signal.

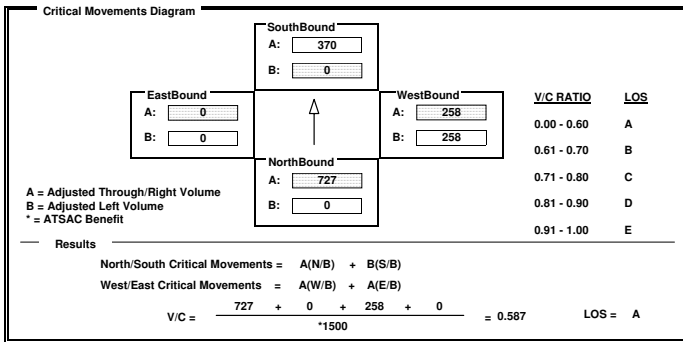

INTERSECTION DATA SUMMARY SHEET

N/S: Douglas St W/E: Imperial Hwy I/S No: 47
AM/PM: MD Comments: Existing
COUNT DATE: STUDY DATE: GROWTH FACTOR:

Volume/Lane/Signal Configurations table with columns for Northbound, Southbound, Westbound, Eastbound and rows for Existing, Ambient, Related, Project, Total, Lane, and Signal.

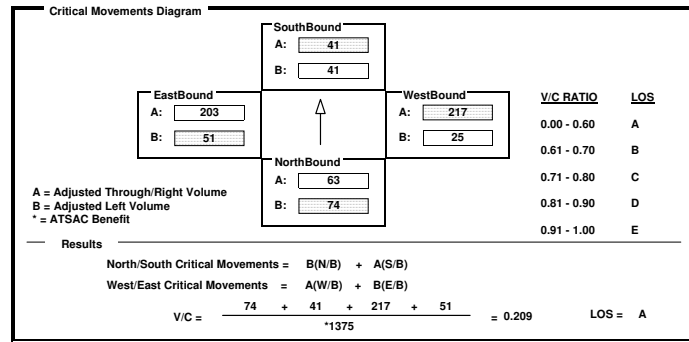

INTERSECTION DATA SUMMARY SHEET

N/S: Lincoln Blvd W/E: Fiji Way I/S No: 56
AM/PM: MD Comments: Existing
COUNT DATE: STUDY DATE: GROWTH FACTOR:

Volume/Lane/Signal Configurations table with columns for Northbound, Southbound, Westbound, Eastbound and rows for Existing, Ambient, Related, Project, Total, Lane, and Signal.

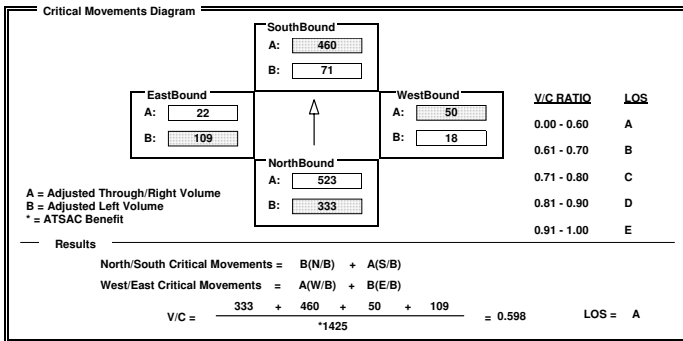

INTERSECTION DATA SUMMARY SHEET

N/S: Sepulveda Blvd W/E: Howard Hughes Pkwy I/S No: 65
AM/PM: MD Comments: Existing
COUNT DATE: STUDY DATE: GROWTH FACTOR:

Volume/Lane/Signal Configurations table with columns for Northbound, Southbound, Westbound, Eastbound and rows for Existing, Ambient, Related, Project, Total, Lane, and Signal.

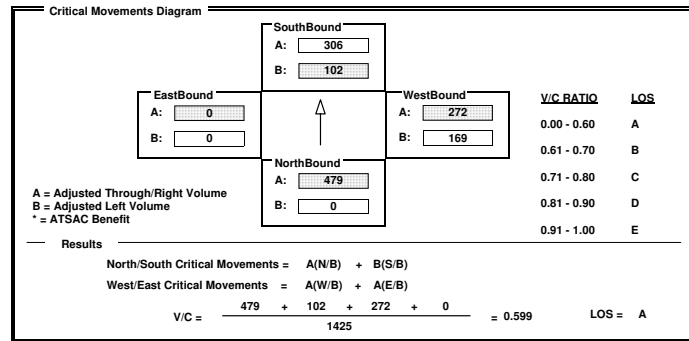

INTERSECTION DATA SUMMARY SHEET

N/S: W/E: I/S No:

AM/PM: Comments:

COUNT DATE: STUDY DATE: GROWTH FACTOR:

	NORTHBOUND			SOUTHBOUND			WESTBOUND			EASTBOUND		
	LT	TH	RT	LT	TH	RT	LT	TH	RT	LT	TH	RT
EXISTING	120	215	213	142	185	225	43	382	233	183	363	140
AMBIENT												
RELATED												
PROJECT												
TOTAL	120	215	213	142	185	225	43	382	233	183	363	140
LANE												
SIGNAL	Phasing		RTOR	Phasing		RTOR	Phasing		RTOR	Phasing		RTOR
	Prot-Fix		Auto	Prot-Fix		Auto	Prot-Fix		OLA	Prot-Fix		OLA

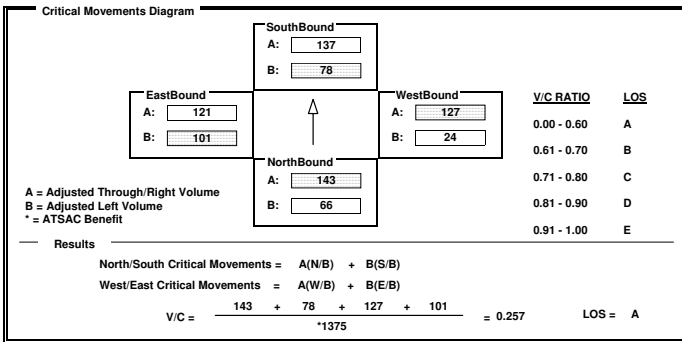

INTERSECTION DATA SUMMARY SHEET

N/S: W/E: I/S No:

AM/PM: Comments:

COUNT DATE: STUDY DATE: GROWTH FACTOR:

	NORTHBOUND			SOUTHBOUND			WESTBOUND			EASTBOUND		
	LT	TH	RT	LT	TH	RT	LT	TH	RT	LT	TH	RT
EXISTING	163	1278	739	256	1606	46	182	290	259	181	279	150
AMBIENT												
RELATED												
PROJECT												
TOTAL	163	1278	739	256	1606	46	182	290	259	181	279	150
LANE												
SIGNAL	Phasing		RTOR	Phasing		RTOR	Phasing		RTOR	Phasing		RTOR
	Prot-Fix		Auto	Prot-Fix		Auto	Prot-Fix		Auto	Prot-Fix		Auto

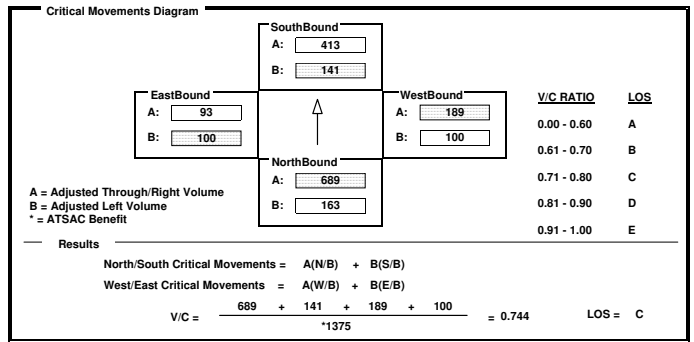

INTERSECTION DATA SUMMARY SHEET

N/S: W/E: I/S No:

AM/PM: Comments:

COUNT DATE: STUDY DATE: GROWTH FACTOR:

	NORTHBOUND			SOUTHBOUND			WESTBOUND			EASTBOUND		
	LT	TH	RT	LT	TH	RT	LT	TH	RT	LT	TH	RT
EXISTING	18	0	43	50	338	171	68	722	0	0	450	54
AMBIENT												
RELATED												
PROJECT												
TOTAL	18	0	43	50	338	171	68	722	0	0	450	54
LANE												
SIGNAL	Phasing		RTOR	Phasing		RTOR	Phasing		RTOR	Phasing		RTOR
	Split		Auto	Split		Auto	Prot-Fix		Auto	Perm		Auto

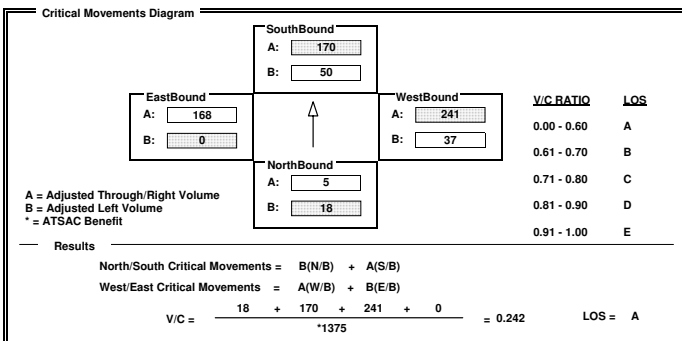

INTERSECTION DATA SUMMARY SHEET

N/S: W/E: I/S No:

AM/PM: Comments:

COUNT DATE: STUDY DATE: GROWTH FACTOR:

	NORTHBOUND			SOUTHBOUND			WESTBOUND			EASTBOUND		
	LT	TH	RT	LT	TH	RT	LT	TH	RT	LT	TH	RT
EXISTING	526	0	552	0	0	0	209	551	0	0	208	486
AMBIENT												
RELATED												
PROJECT												
TOTAL	526	0	552	0	0	0	209	551	0	0	208	486
LANE												
SIGNAL	Phasing		RTOR	Phasing		RTOR	Phasing		RTOR	Phasing		RTOR
	Split		OLA	<none>		<none>	Prot-Fix		Auto	Perm		OLA

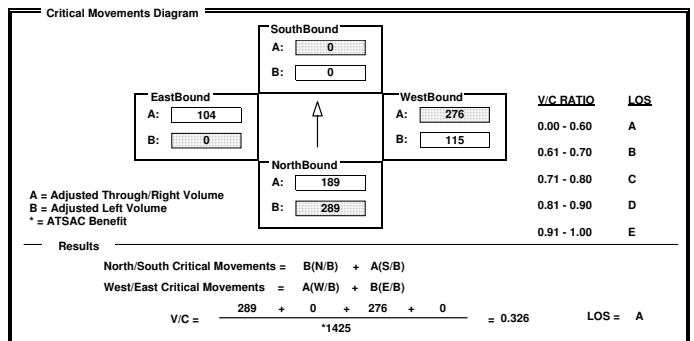

INTERSECTION DATA SUMMARY SHEET

N/S: Lincoln Blvd W/E: Jefferson Blvd I/S No: 78
AM/PM: MD Comments: Existing
COUNT DATE: STUDY DATE: GROWTH FACTOR:

Volume/Lane/Signal Configurations table with columns for Northbound, Southbound, Westbound, Eastbound and rows for Existing, Ambient, Related, Project, Total, Lane, Phasing, RTOR, Signal.

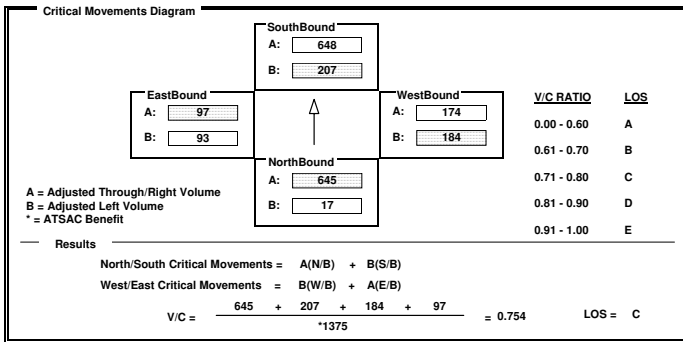

INTERSECTION DATA SUMMARY SHEET

N/S: La Cienega Blvd W/E: La Tijera Blvd I/S No: 88
AM/PM: MD Comments: Existing
COUNT DATE: STUDY DATE: GROWTH FACTOR:

Volume/Lane/Signal Configurations table with columns for Northbound, Southbound, Westbound, Eastbound and rows for Existing, Ambient, Related, Project, Total, Lane, Phasing, RTOR, Signal.

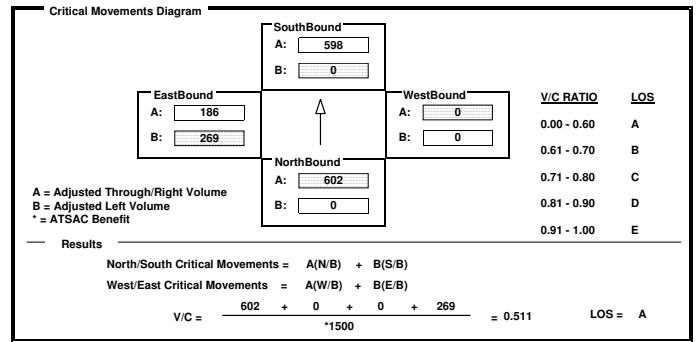

INTERSECTION DATA SUMMARY SHEET

N/S: Lincoln Blvd W/E: La Tijera Blvd I/S No: 99
AM/PM: MD Comments: Existing
COUNT DATE: STUDY DATE: GROWTH FACTOR:

Volume/Lane/Signal Configurations table with columns for Northbound, Southbound, Westbound, Eastbound and rows for Existing, Ambient, Related, Project, Total, Lane, Phasing, RTOR, Signal.

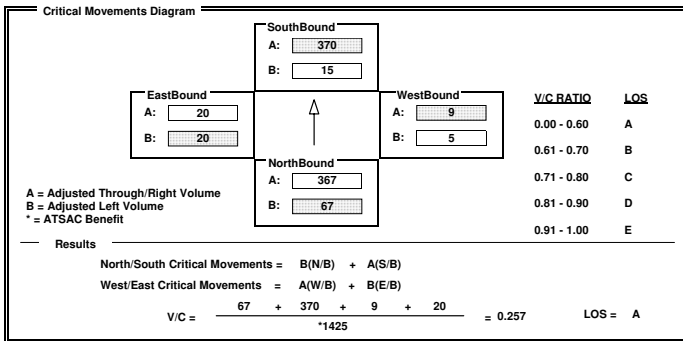

INTERSECTION DATA SUMMARY SHEET

N/S: La Tijera W/E: Manchester Ave I/S No: 100
AM/PM: MD Comments: Existing
COUNT DATE: STUDY DATE: GROWTH FACTOR:

Volume/Lane/Signal Configurations table with columns for Northbound, Southbound, Westbound, Eastbound and rows for Existing, Ambient, Related, Project, Total, Lane, Phasing, RTOR, Signal.

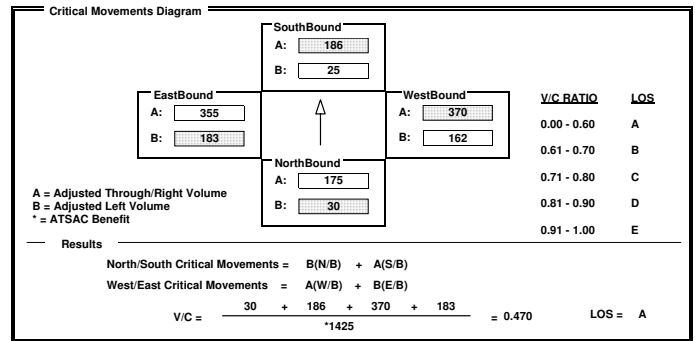

INTERSECTION DATA SUMMARY SHEET

N/S: W/E: I/S No:

AM/PM: Comments:

COUNT DATE: STUDY DATE: GROWTH FACTOR:

Volume/Lane/Signal Configurations

	NORTHBOUND			SOUTHBOUND			WESTBOUND			EASTBOUND								
	LT	TH	RT	LT	TH	RT	LT	TH	RT	LT	TH	RT						
EXISTING	104	1179	160	59	1092	47	261	210	69	77	257	68						
AMBIENT																		
RELATED																		
PROJECT																		
TOTAL	104	1179	160	59	1092	47	261	210	69	77	257	68						
LANE	1 3 1	1 3 1	1 3 1	1 3 1	1 3 1	1 3 1	1 2 1	1 2 1	1 2 1	1 2 1	1 2 1	1 2 1						
Phasing	Perm			Auto			Perm			Auto			Perm			Auto		
RTOR	Auto			Auto			Auto			Auto			Auto			Auto		
SIGNAL	Perm			Auto			Perm			Auto			Perm			Auto		

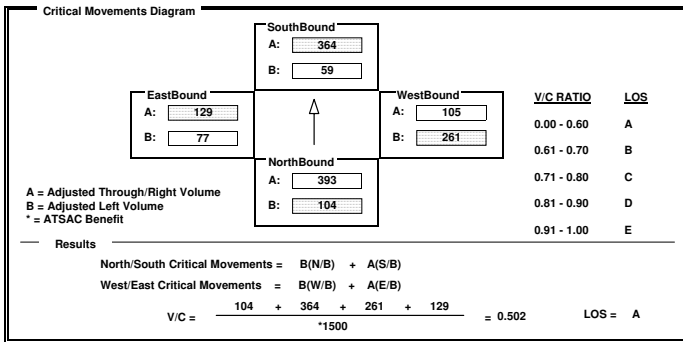

INTERSECTION DATA SUMMARY SHEET

N/S: W/E: I/S No:

AM/PM: Comments:

COUNT DATE: STUDY DATE: GROWTH FACTOR:

Volume/Lane/Signal Configurations

	NORTHBOUND			SOUTHBOUND			WESTBOUND			EASTBOUND								
	LT	TH	RT	LT	TH	RT	LT	TH	RT	LT	TH	RT						
EXISTING	149	0	245	0	0	0	0	1095	214	381	927	0						
AMBIENT																		
RELATED																		
PROJECT																		
TOTAL	149	0	245	0	0	0	0	1095	214	381	927	0						
LANE	1 1 1		1 1					3 1 1		1 3 1								
Phasing	Split			Auto			<none>			<none>			Perm			Auto		
RTOR	Auto			Auto			<none>			<none>			Auto			Auto		
SIGNAL	Split			Auto			<none>			<none>			Prot-Fix			<none>		

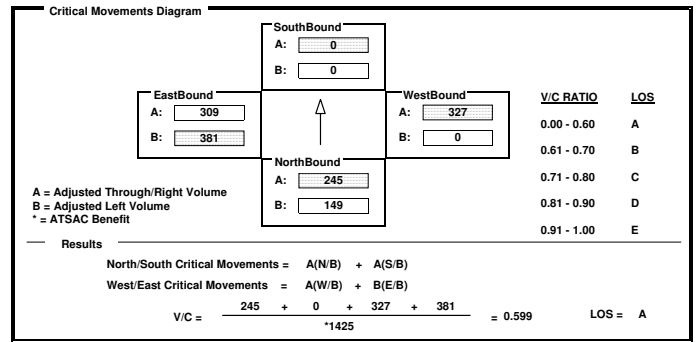

INTERSECTION DATA SUMMARY SHEET

N/S: W/E: I/S No:

AM/PM: Comments:

COUNT DATE: STUDY DATE: GROWTH FACTOR:

Volume/Lane/Signal Configurations

	NORTHBOUND			SOUTHBOUND			WESTBOUND			EASTBOUND					
	LT	TH	RT	LT	TH	RT	LT	TH	RT	LT	TH	RT			
EXISTING	0	0	0	163	0	445	206	1038	0	0	1145	172			
AMBIENT															
RELATED															
PROJECT															
TOTAL	0	0	0	163	0	445	206	1038	0	0	1145	172			
LANE						1 1	1 3			3 1					
Phasing	<none>			Split			Prot-Fix			Perm			Auto		
RTOR	<none>			Auto			Auto			Auto			Auto		
SIGNAL	<none>			Split			Prot-Fix			Perm			Auto		

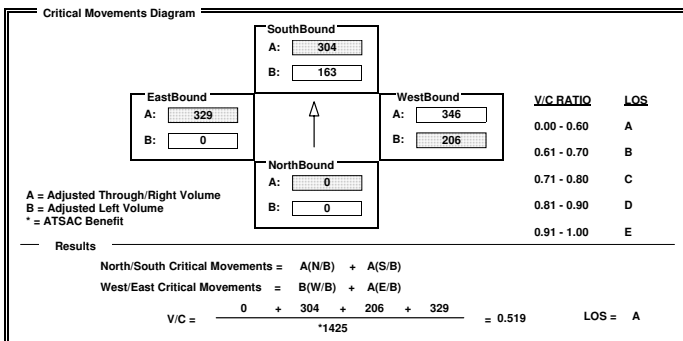

INTERSECTION DATA SUMMARY SHEET

N/S: W/E: I/S No:

AM/PM: Comments:

COUNT DATE: STUDY DATE: GROWTH FACTOR:

Volume/Lane/Signal Configurations

	NORTHBOUND			SOUTHBOUND			WESTBOUND			EASTBOUND								
	LT	TH	RT	LT	TH	RT	LT	TH	RT	LT	TH	RT						
EXISTING	9	1456	116	138	1524	17	93	1	90	16	8	12						
AMBIENT																		
RELATED																		
PROJECT																		
TOTAL	9	1456	116	138	1524	17	93	1	90	16	8	12						
LANE	1 2 1	2 2 1	1 1 1	1 1 1	1 1 1	1 1 1	1 1 1	1 1 1	1 1 1	1 1 1	1 1 1	1 1 1						
Phasing	Prot-Fix			Auto			Prot-Fix			Auto			Perm			Auto		
RTOR	Auto			Auto			Auto			Auto			Auto			Auto		
SIGNAL	Prot-Fix			Auto			Prot-Fix			Auto			Perm			Auto		

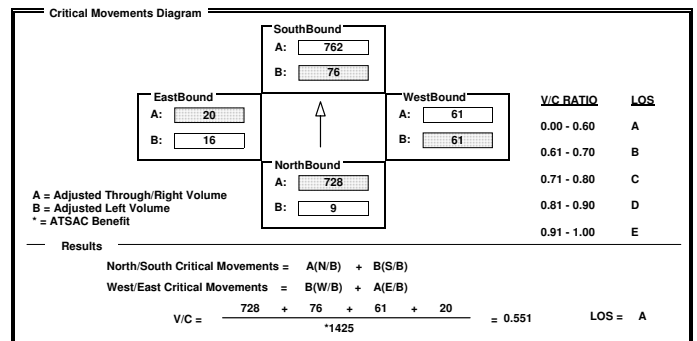

INTERSECTION DATA SUMMARY SHEET

N/S: Lincoln Blvd W/E: Manchester Blvd I/S No: 105
AM/PM: MD Comments: Existing
COUNT DATE: STUDY DATE: GROWTH FACTOR:

Volume/Lane/Signal Configurations table with columns for Northbound, Southbound, Westbound, Eastbound and rows for Existing, Ambient, Related, Project, Total, Lane, Phasing, RTOR, Signal.

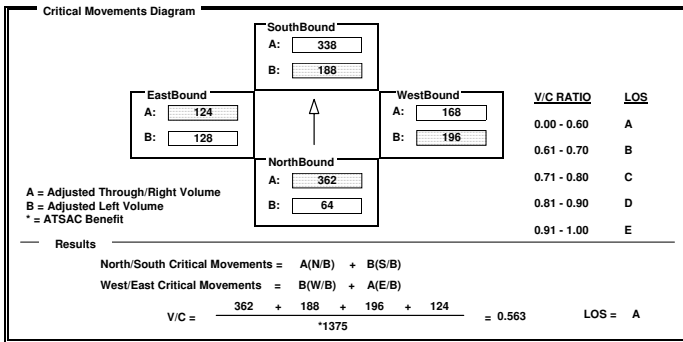

INTERSECTION DATA SUMMARY SHEET

N/S: Lincoln Blvd W/E: Marina Pointe Dr/ Maxella Ave I/S No: 106
AM/PM: MD Comments: Existing
COUNT DATE: STUDY DATE: GROWTH FACTOR:

Volume/Lane/Signal Configurations table with columns for Northbound, Southbound, Westbound, Eastbound and rows for Existing, Ambient, Related, Project, Total, Lane, Phasing, RTOR, Signal.

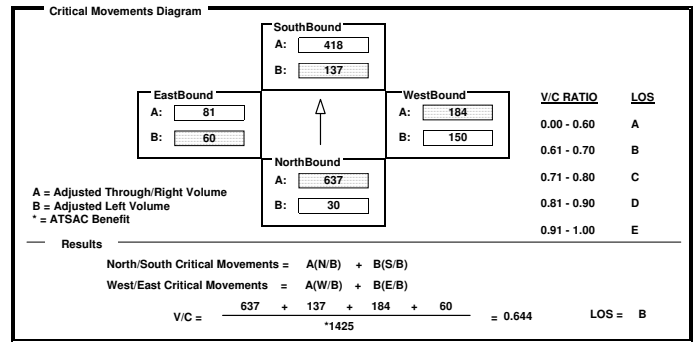

INTERSECTION DATA SUMMARY SHEET

N/S: Lincoln Blvd W/E: Mindanao Way I/S No: 107
AM/PM: MD Comments: Existing
COUNT DATE: STUDY DATE: GROWTH FACTOR:

Volume/Lane/Signal Configurations table with columns for Northbound, Southbound, Westbound, Eastbound and rows for Existing, Ambient, Related, Project, Total, Lane, Phasing, RTOR, Signal.

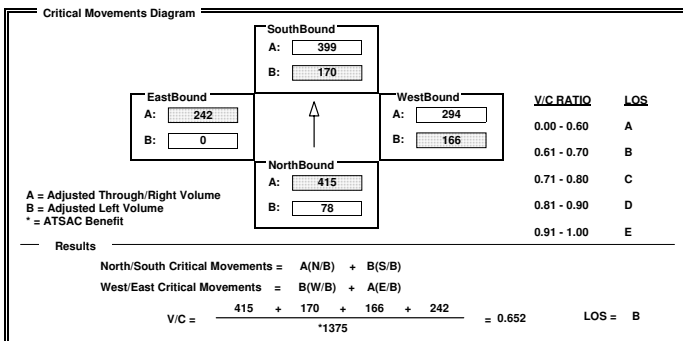

INTERSECTION DATA SUMMARY SHEET

N/S: Sepulveda Blvd W/E: Lincoln Blvd I/S No: 108
AM/PM: MD Comments: Existing
COUNT DATE: STUDY DATE: GROWTH FACTOR:

Volume/Lane/Signal Configurations table with columns for Northbound, Southbound, Westbound, Eastbound and rows for Existing, Ambient, Related, Project, Total, Lane, Phasing, RTOR, Signal.

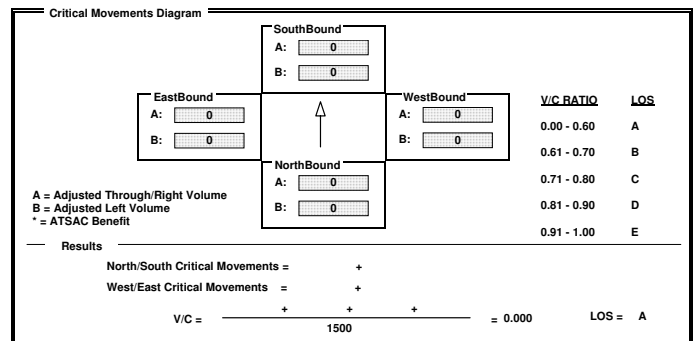

INTERSECTION DATA SUMMARY SHEET

N/S: Lincoln Blvd W/E: Venice Blvd I/S No: 109
 AM/PM: MD Comments: Existing
 COUNT DATE: STUDY DATE: GROWTH FACTOR:

	NORTHBOUND			SOUTHBOUND			WESTBOUND			EASTBOUND		
	LT	TH	RT	LT	TH	RT	LT	TH	RT	LT	TH	RT
EXISTING	228	1606	147	232	1775	105	252	564	190	120	598	206
AMBIENT												
RELATED												
PROJECT												
TOTAL	228	1606	147	232	1775	105	252	564	190	120	598	206
LANE	2	2	1	2	2	1	2	2	1	2	3	1
SIGNAL	Prot-Fix	Auto	Prot-Fix	Auto	Prot-Fix	OLA	Prot-Fix	OLA	Prot-Fix	OLA	Prot-Fix	OLA

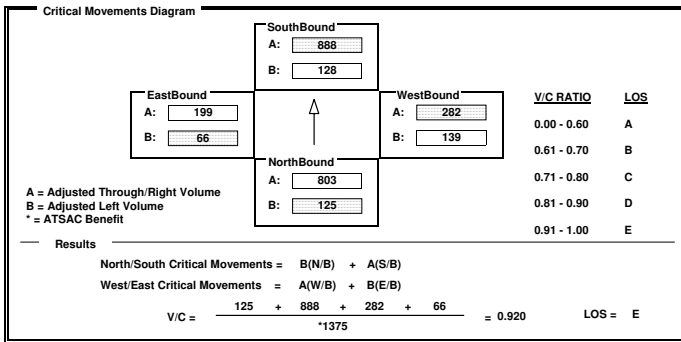

INTERSECTION DATA SUMMARY SHEET

N/S: Lincoln Blvd W/E: Washington Blvd I/S No: 110
 AM/PM: MD Comments: Existing
 COUNT DATE: STUDY DATE: GROWTH FACTOR:

	NORTHBOUND			SOUTHBOUND			WESTBOUND			EASTBOUND		
	LT	TH	RT	LT	TH	RT	LT	TH	RT	LT	TH	RT
EXISTING	313	1567	332	319	1535	161	269	679	356	166	635	240
AMBIENT												
RELATED												
PROJECT												
TOTAL	313	1567	332	319	1535	161	269	679	356	166	635	240
LANE	2	2	1	2	2	1	2	2	1	2	2	1
SIGNAL	Prot-Fix	Auto	Prot-Fix	Auto	Prot-Fix	OLA	Prot-Fix	OLA	Prot-Fix	OLA	Prot-Fix	OLA

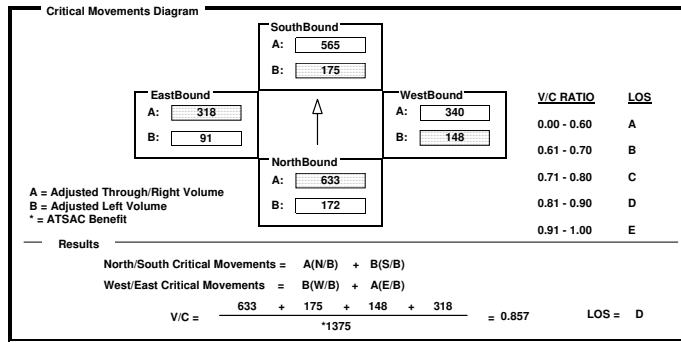

INTERSECTION DATA SUMMARY SHEET

N/S: Lincoln Blvd W/E: 83rd St I/S No: 111
 AM/PM: MD Comments: Existing
 COUNT DATE: STUDY DATE: GROWTH FACTOR:

	NORTHBOUND			SOUTHBOUND			WESTBOUND			EASTBOUND		
	LT	TH	RT	LT	TH	RT	LT	TH	RT	LT	TH	RT
EXISTING	38	1228	20	151	1193	138	43	50	148	26	61	126
AMBIENT												
RELATED												
PROJECT												
TOTAL	38	1228	20	151	1193	138	43	50	148	26	61	126
LANE	1	1	1	1	1	1	1	1	1	1	1	1
SIGNAL	Perm	Auto	Prot-Fix	Auto	Perm	OLA	Prot-Fix	Auto	Prot-Fix	Auto	Prot-Fix	Auto

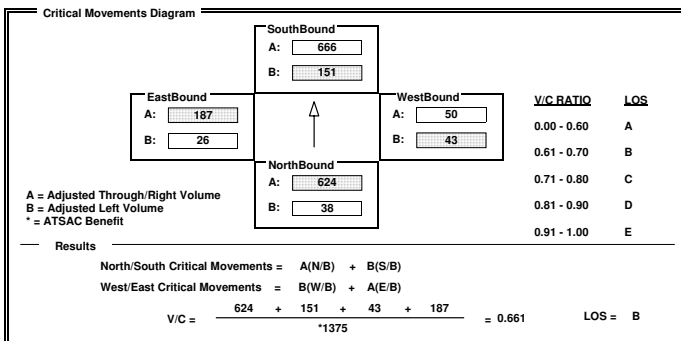

INTERSECTION DATA SUMMARY SHEET

N/S: Sepulveda Blvd W/E: Manchester Ave I/S No: 114
 AM/PM: MD Comments: Existing
 COUNT DATE: STUDY DATE: GROWTH FACTOR:

	NORTHBOUND			SOUTHBOUND			WESTBOUND			EASTBOUND		
	LT	TH	RT	LT	TH	RT	LT	TH	RT	LT	TH	RT
EXISTING	152	914	142	221	981	213	112	624	194	286	721	85
AMBIENT												
RELATED												
PROJECT												
TOTAL	152	914	142	221	981	213	112	624	194	286	721	85
LANE	1	3	1	1	3	1	1	2	1	2	2	1
SIGNAL	Prot-Fix	Auto	Prot-Fix	Auto	Prot-Fix	Auto	Prot-Fix	Auto	Prot-Fix	Auto	Prot-Fix	Auto

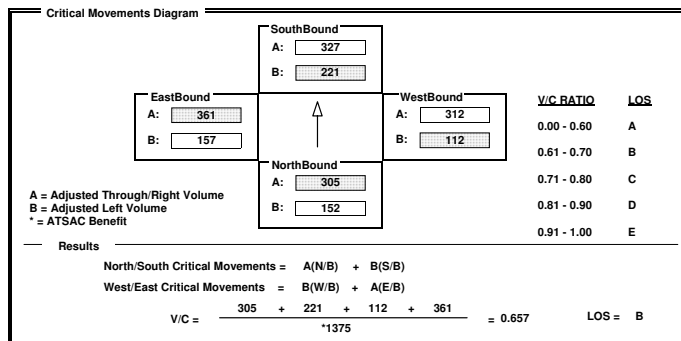

INTERSECTION DATA SUMMARY SHEET

N/S: Sepulveda Blvd W/E: Westchester Pkwy I/S No: 135
AM/PM: MD Comments: Existing
COUNT DATE: STUDY DATE: GROWTH FACTOR:

Volume/Lane/Signal Configurations table with columns for Northbound, Southbound, Westbound, Eastbound and rows for Existing, Ambient, Related, Project, Total, Lane, Phasing, RTOR, Signal.

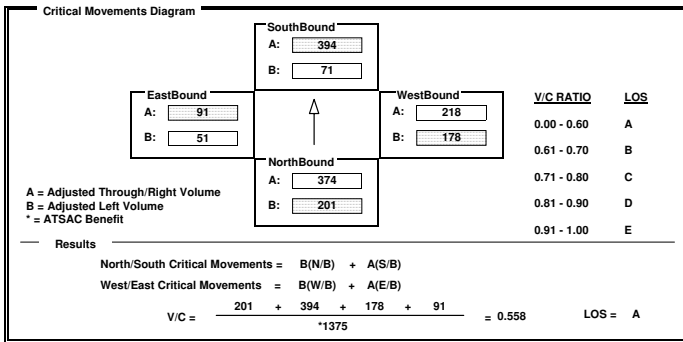

INTERSECTION DATA SUMMARY SHEET

N/S: Sepulveda Blvd W/E: 76th St/77th St I/S No: 136
AM/PM: MD Comments: Existing
COUNT DATE: STUDY DATE: GROWTH FACTOR:

Volume/Lane/Signal Configurations table with columns for Northbound, Southbound, Westbound, Eastbound and rows for Existing, Ambient, Related, Project, Total, Lane, Phasing, RTOR, Signal.

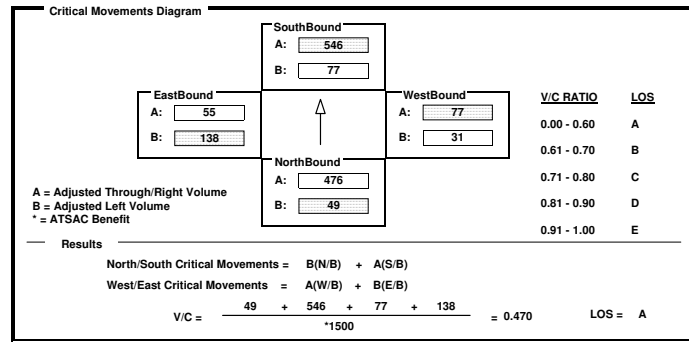

INTERSECTION DATA SUMMARY SHEET

N/S: Sepulveda Blvd W/E: 79 St/80th St I/S No: 137
AM/PM: MD Comments: Existing
COUNT DATE: STUDY DATE: GROWTH FACTOR:

Volume/Lane/Signal Configurations table with columns for Northbound, Southbound, Westbound, Eastbound and rows for Existing, Ambient, Related, Project, Total, Lane, Phasing, RTOR, Signal.

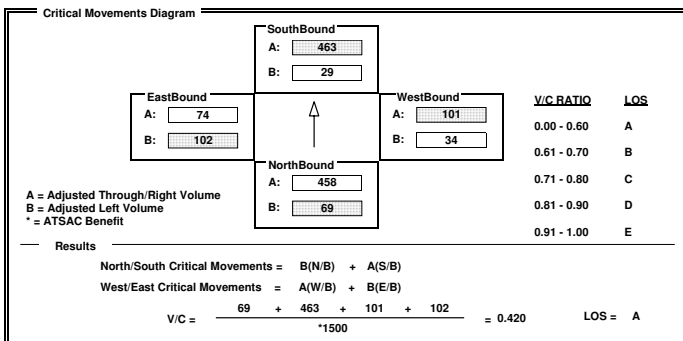

INTERSECTION DATA SUMMARY SHEET

N/S: Sepulveda Blvd W/E: 83rd St I/S No: 138
AM/PM: MD Comments: Existing
COUNT DATE: STUDY DATE: GROWTH FACTOR:

Volume/Lane/Signal Configurations table with columns for Northbound, Southbound, Westbound, Eastbound and rows for Existing, Ambient, Related, Project, Total, Lane, Phasing, RTOR, Signal.

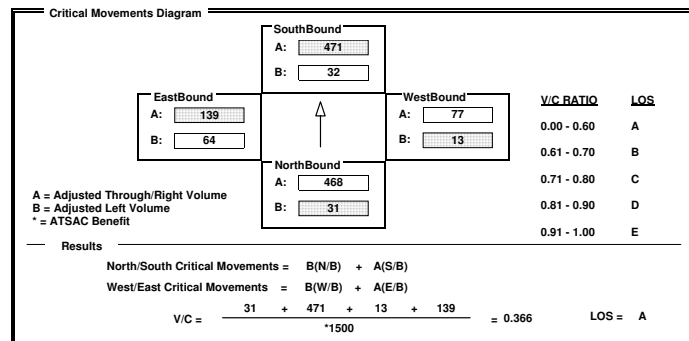

INTERSECTION DATA SUMMARY SHEET

N/S: Sepulveda Blvd W/E: I-105 WB Ramp I/S No: 139
 AM/PM: MD Comments: Existing
 COUNT DATE: STUDY DATE: GROWTH FACTOR:

	NORTHBOUND			SOUTHBOUND			WESTBOUND			EASTBOUND		
	LT	TH	RT	LT	TH	RT	LT	TH	RT	LT	TH	RT
EXISTING	0	1718	0	0	0	0	0	0	2068	0	0	0
AMBIENT												
RELATED												
PROJECT												
TOTAL	0	1718	0	0	0	0	0	0	2068	0	0	0
LANE	1 2 1			1 2 1			1 1 1			1 1 1		
SIGNAL	Phasing		RTOR	Phasing		RTOR	Phasing		RTOR	Phasing		RTOR
	Split		<none>	<none>		<none>	Split		<none>	<none>		<none>

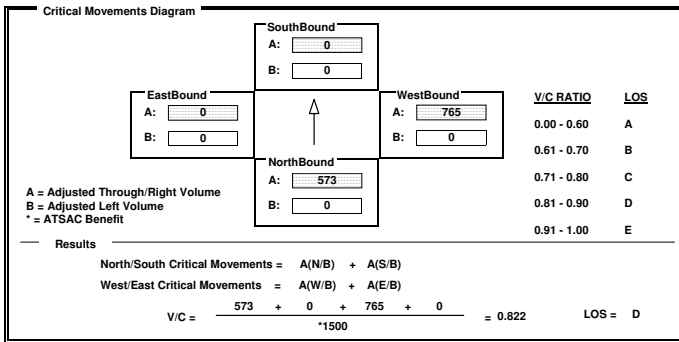

INTERSECTION DATA SUMMARY SHEET

N/S: Airport Blvd W/E: 96th St I/S No: 141
 AM/PM: MD Comments: Existing
 COUNT DATE: STUDY DATE: GROWTH FACTOR:

	NORTHBOUND			SOUTHBOUND			WESTBOUND			EASTBOUND		
	LT	TH	RT	LT	TH	RT	LT	TH	RT	LT	TH	RT
EXISTING	160	855	40	75	607	239	27	31	110	149	37	102
AMBIENT												
RELATED												
PROJECT												
TOTAL	160	855	40	75	607	239	27	31	110	149	37	102
LANE	1 2 1			1 3 1			1 1 1			2 1 1		
SIGNAL	Phasing		RTOR	Phasing		RTOR	Phasing		RTOR	Phasing		RTOR
	Prot-Fix		Auto	Perm		Free	Perm		Auto	Prot-Fix		Auto

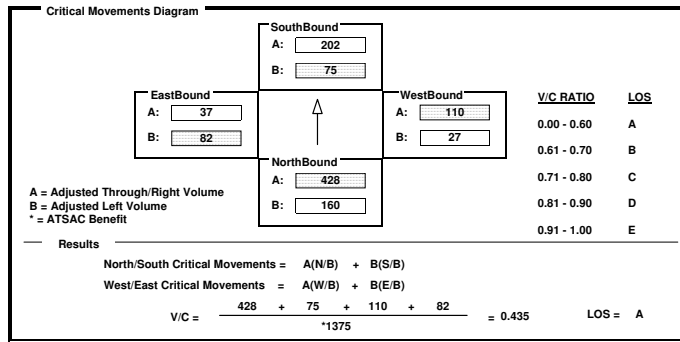

INTERSECTION DATA SUMMARY SHEET

N/S: Airport Blvd W/E: 98 St I/S No: 144
 AM/PM: MD Comments: Existing
 COUNT DATE: STUDY DATE: GROWTH FACTOR:

	NORTHBOUND			SOUTHBOUND			WESTBOUND			EASTBOUND		
	LT	TH	RT	LT	TH	RT	LT	TH	RT	LT	TH	RT
EXISTING	80	770	65	82	596	92	46	41	101	185	57	53
AMBIENT												
RELATED												
PROJECT												
TOTAL	80	770	65	82	596	92	46	41	101	185	57	53
LANE	1 2 1			1 2 1			1 1 1			1 1 1		
SIGNAL	Phasing		RTOR	Phasing		RTOR	Phasing		RTOR	Phasing		RTOR
	Perm		Auto	Perm		Auto	Perm		Auto	Perm		Auto

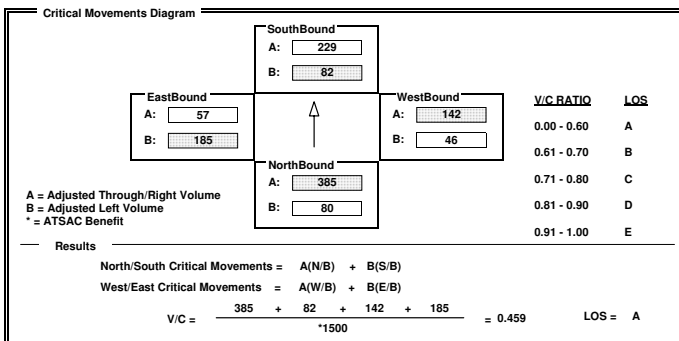

INTERSECTION DATA SUMMARY SHEET

N/S: Sepulveda Eastway W/E: Westchester Pkwy I/S No: 146
 AM/PM: MD Comments: Existing
 COUNT DATE: STUDY DATE: GROWTH FACTOR:

	NORTHBOUND			SOUTHBOUND			WESTBOUND			EASTBOUND		
	LT	TH	RT	LT	TH	RT	LT	TH	RT	LT	TH	RT
EXISTING	25	193	111	212	14	97	17	477	150	65	230	9
AMBIENT												
RELATED												
PROJECT												
TOTAL	25	193	111	212	14	97	17	477	150	65	230	9
LANE	1 1 1			1 1 1			1 1 1			1 1 1		
SIGNAL	Phasing		RTOR	Phasing		RTOR	Phasing		RTOR	Phasing		RTOR
	Perm		Auto	Perm		Auto	Perm		Auto	Perm		Auto

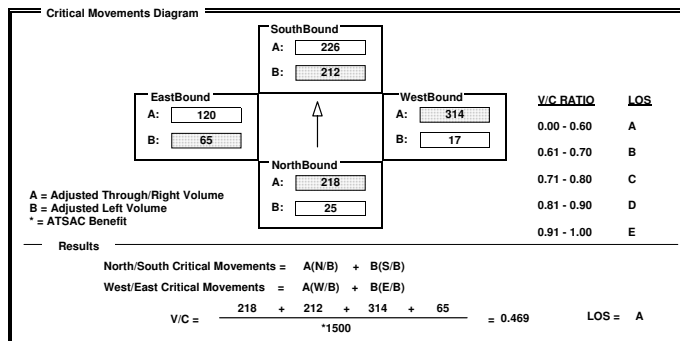

INTERSECTION DATA SUMMARY SHEET

N/S: W/E: I/S No:

AM/PM: Comments:

COUNT DATE: STUDY DATE: GROWTH FACTOR:

	NORTHBOUND			SOUTHBOUND			WESTBOUND			EASTBOUND		
	LT	TH	RT	LT	TH	RT	LT	TH	RT	LT	TH	RT
EXISTING	0	501	140	140	582	0	815	0	70	0	0	0
AMBIENT												
RELATED												
PROJECT												
TOTAL	0	501	140	140	582	0	815	0	70	0	0	0
LANE	1 1 1			1 2			1			1		
SIGNAL	Phasing		RTOR	Phasing		RTOR	Phasing		RTOR	Phasing		RTOR
	Prot-Fix		Auto	Prot-Fix		Auto	Prot-Fix		Auto	Prot-Fix		Auto

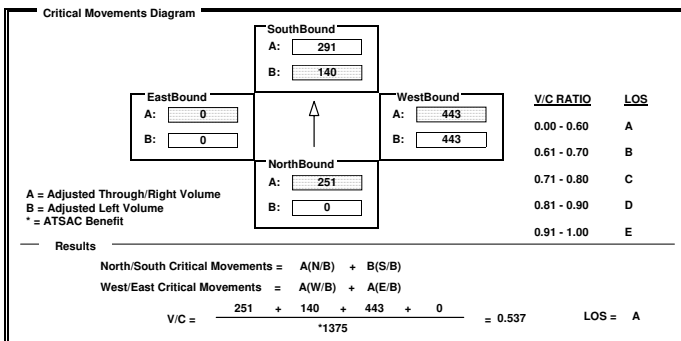

INTERSECTION DATA SUMMARY SHEET

N/S: W/E: I/S No:

AM/PM: Comments:

COUNT DATE: STUDY DATE: GROWTH FACTOR:

	NORTHBOUND			SOUTHBOUND			WESTBOUND			EASTBOUND		
	LT	TH	RT	LT	TH	RT	LT	TH	RT	LT	TH	RT
EXISTING	0	565	38	667	460	0	0	0	240	0	0	0
AMBIENT												
RELATED												
PROJECT												
TOTAL	0	565	38	667	460	0	0	0	240	0	0	0
LANE	1 1			2 2			2			1 1		
SIGNAL	Phasing		RTOR	Phasing		RTOR	Phasing		RTOR	Phasing		RTOR
	Prot-Fix		Auto	Prot-Fix		Auto	Prot-Fix		Auto	Prot-Fix		Auto

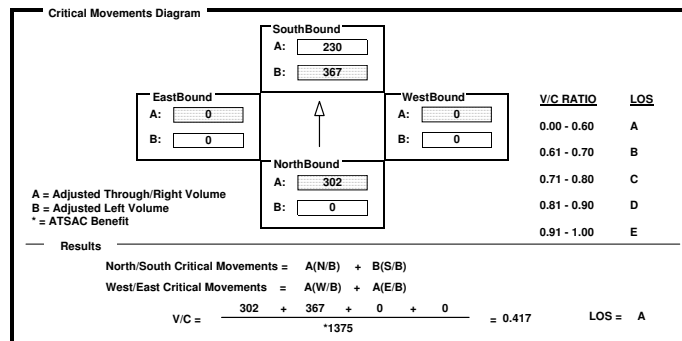

INTERSECTION DATA SUMMARY SHEET

N/S: W/E: I/S No:

AM/PM: Comments:

COUNT DATE: STUDY DATE: GROWTH FACTOR:

	NORTHBOUND			SOUTHBOUND			WESTBOUND			EASTBOUND		
	LT	TH	RT	LT	TH	RT	LT	TH	RT	LT	TH	RT
EXISTING	152	1703	124	137	1375	23	141	690	130	1	683	177
AMBIENT												
RELATED												
PROJECT												
TOTAL	152	1703	124	137	1375	23	141	690	130	1	683	177
LANE	2 2 1			1 2 1			1 2 1			2 1		
SIGNAL	Phasing		RTOR	Phasing		RTOR	Phasing		RTOR	Phasing		RTOR
	Prot-Fix		Auto	Prot-Fix		Auto	Prot-Fix		Auto	Prot-Fix		Auto

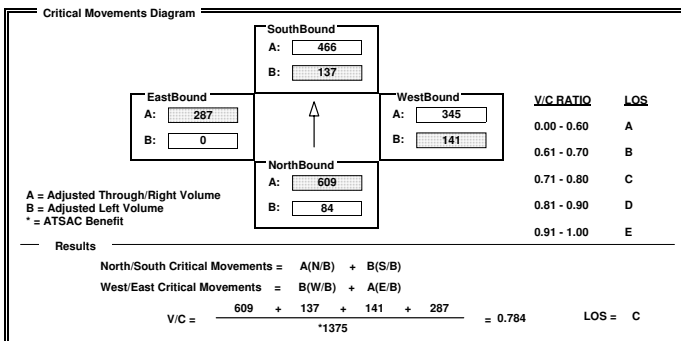

INTERSECTION DATA SUMMARY SHEET

N/S: W/E: I/S No:

AM/PM: Comments:

COUNT DATE: STUDY DATE: GROWTH FACTOR:

	NORTHBOUND			SOUTHBOUND			WESTBOUND			EASTBOUND		
	LT	TH	RT	LT	TH	RT	LT	TH	RT	LT	TH	RT
EXISTING	51	1057	129	110	864	128	222	1012	106	149	929	67
AMBIENT												
RELATED												
PROJECT												
TOTAL	51	1057	129	110	864	128	222	1012	106	149	929	67
LANE	1 2 1			1 2 1			1 2 1			1 2 1		
SIGNAL	Phasing		RTOR	Phasing		RTOR	Phasing		RTOR	Phasing		RTOR
	Prot-Fix		Auto	Prot-Fix		Auto	Prot-Fix		Auto	Prot-Fix		Auto

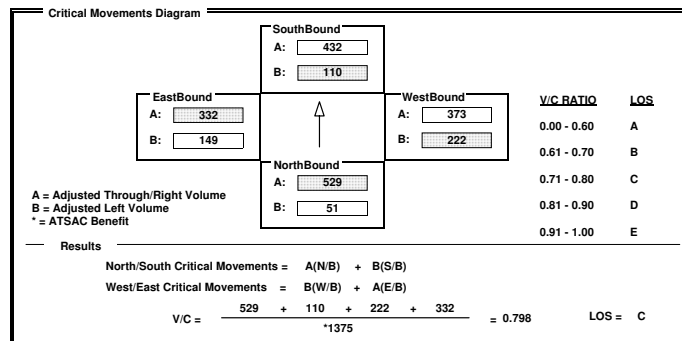

INTERSECTION DATA SUMMARY SHEET

N/S: W/E: I/S No:

AM/PM: Comments:

COUNT DATE: STUDY DATE: GROWTH FACTOR:

	NORTHBOUND			SOUTHBOUND			WESTBOUND			EASTBOUND		
	LT	TH	RT	LT	TH	RT	LT	TH	RT	LT	TH	RT
EXISTING	108	477	35	154	634	111	30	870	139	136	664	95
AMBIENT												
RELATED												
PROJECT												
TOTAL	108	477	35	154	634	111	30	870	139	136	664	95
LANE	1 1 1			1 2 1			1 2 1			1 2 1		
SIGNAL	Prot-Fix		Auto	Prot-Fix		Auto	Prot-Fix		Auto	Prot-Fix		Auto

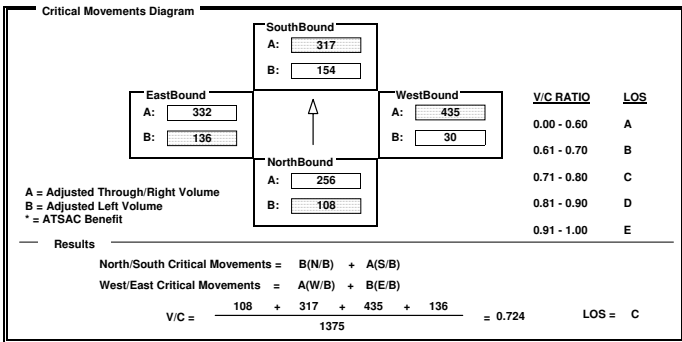

INTERSECTION DATA SUMMARY SHEET

N/S: W/E: I/S No:

AM/PM: Comments:

COUNT DATE: STUDY DATE: GROWTH FACTOR:

	NORTHBOUND			SOUTHBOUND			WESTBOUND			EASTBOUND		
	LT	TH	RT	LT	TH	RT	LT	TH	RT	LT	TH	RT
EXISTING	0	1809	692	137	0	0	668	0	52	0	0	0
AMBIENT												
RELATED												
PROJECT												
TOTAL	0	1809	692	137	0	0	668	0	52	0	0	0
LANE	2 1 1			1 1 1			2 1 1			1 1 1		
SIGNAL	Prot-Fix		Auto	Prot-Fix			Split		Free			

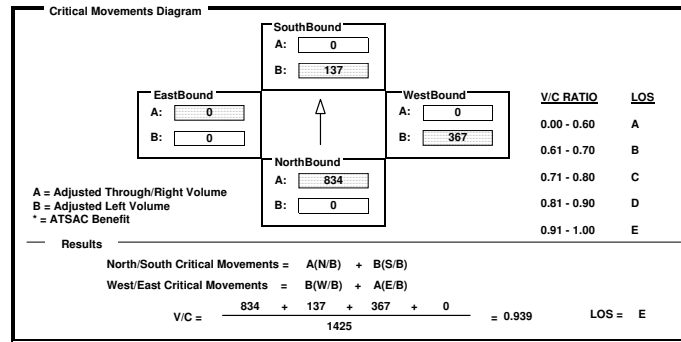

INTERSECTION DATA SUMMARY SHEET

N/S: W/E: I/S No:

AM/PM: Comments:

COUNT DATE: STUDY DATE: GROWTH FACTOR:

	NORTHBOUND			SOUTHBOUND			WESTBOUND			EASTBOUND		
	LT	TH	RT	LT	TH	RT	LT	TH	RT	LT	TH	RT
EXISTING	133	789	140	88	498	134	218	1393	178	169	1136	76
AMBIENT												
RELATED												
PROJECT												
TOTAL	133	789	140	88	498	134	218	1393	178	169	1136	76
LANE	1 2 1			1 2 1			2 2 1			2 2 1		
SIGNAL	Prot-Fix		OLA	Prot-Fix		OLA	Prot-Fix		Auto	Prot-Fix		Auto

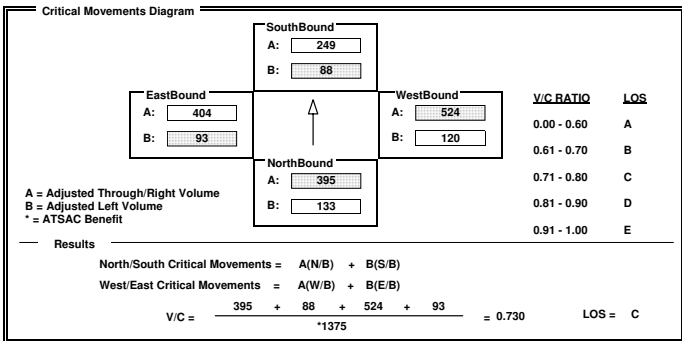

INTERSECTION DATA SUMMARY SHEET

N/S: W/E: I/S No:

AM/PM: Comments:

COUNT DATE: STUDY DATE: GROWTH FACTOR:

	NORTHBOUND			SOUTHBOUND			WESTBOUND			EASTBOUND		
	LT	TH	RT	LT	TH	RT	LT	TH	RT	LT	TH	RT
EXISTING	112	1428	38	83	1356	208	93	233	109	273	258	173
AMBIENT												
RELATED												
PROJECT												
TOTAL	112	1428	38	83	1356	208	93	233	109	273	258	173
LANE	1 2 1			1 2 1			1 1 1			1 1 1		
SIGNAL	Perm		Auto	Perm		Auto	Perm		Auto	Perm		Auto

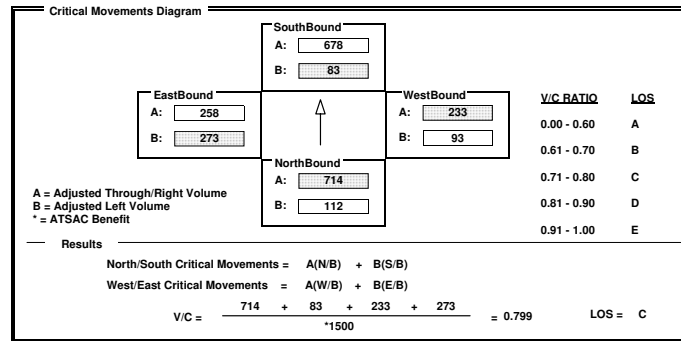

INTERSECTION DATA SUMMARY SHEET

N/S: Western Ave W/E: Century Blvd I/S No: 161
AM/PM: MD Comments: Existing
COUNT DATE: STUDY DATE: GROWTH FACTOR:

Volume/Lane/Signal Configurations table with columns for Northbound, Southbound, Westbound, Eastbound and rows for Existing, Ambient, Related, Project, Total, Lane, and Signal.

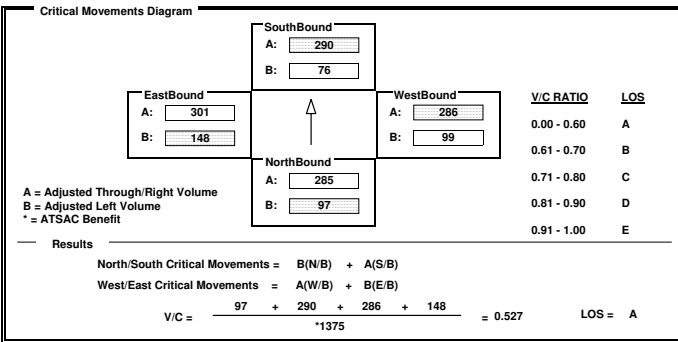

INTERSECTION DATA SUMMARY SHEET

N/S: La Cienega Blvd W/E: Jefferson Blvd I/S No: 200
AM/PM: MD Comments: Existing
COUNT DATE: STUDY DATE: GROWTH FACTOR:

Volume/Lane/Signal Configurations table with columns for Northbound, Southbound, Westbound, Eastbound and rows for Existing, Ambient, Related, Project, Total, Lane, and Signal.

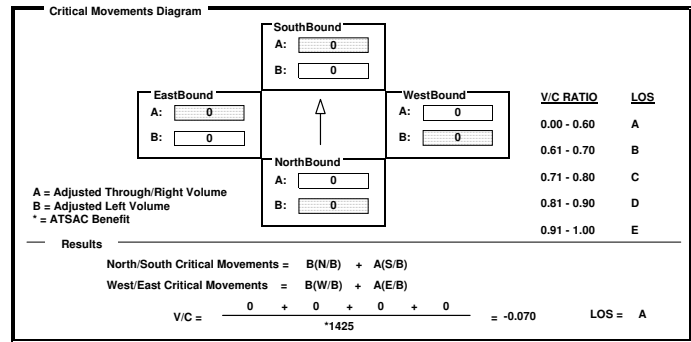

INTERSECTION DATA SUMMARY SHEET

N/S: Airport Blvd W/E: Westchester Blvd I/S No: 6
AM/PM: PM Comments: Existing
COUNT DATE: STUDY DATE: GROWTH FACTOR:

Volume/Lane/Signal Configurations table with columns for Northbound, Southbound, Westbound, Eastbound and rows for Existing, Ambient, Related, Project, Total, Lane, and Signal.

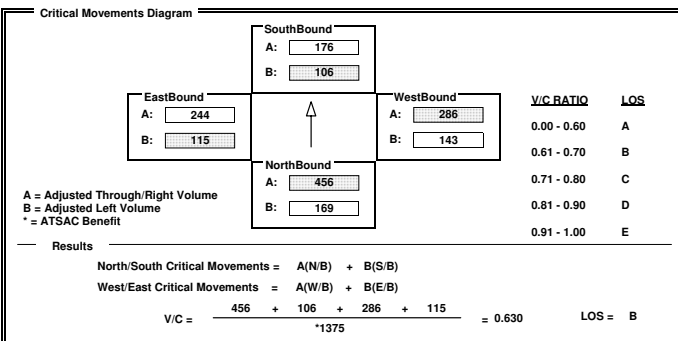

INTERSECTION DATA SUMMARY SHEET

N/S: Airport Blvd W/E: Century Blvd I/S No: 7
AM/PM: PM Comments: Existing
COUNT DATE: STUDY DATE: GROWTH FACTOR:

Volume/Lane/Signal Configurations table with columns for Northbound, Southbound, Westbound, Eastbound and rows for Existing, Ambient, Related, Project, Total, Lane, and Signal.

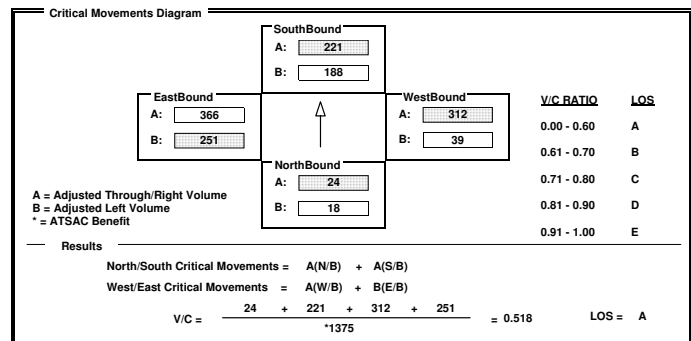

INTERSECTION DATA SUMMARY SHEET

N/S: Airport Blvd W/E: La Tijera Blvd I/S No: 8
 AM/PM: PM Comments: Existing
 COUNT DATE: STUDY DATE: GROWTH FACTOR:

	NORTHBOUND			SOUTHBOUND			WESTBOUND			EASTBOUND		
	LT	TH	RT	LT	TH	RT	LT	TH	RT	LT	TH	RT
EXISTING	30	109	825	47	100	9	515	726	26	26	711	22
AMBIENT												
RELATED												
PROJECT												
TOTAL	30	109	825	47	100	9	515	726	26	26	711	22
LANE	1 2 1			1 1 1			2 1 1			1 2 1		
SIGNAL	Phasing		RTOR	Phasing		RTOR	Phasing		RTOR	Phasing		RTOR
	Split		OLA	Split		Auto	Prot-Fix		Auto	Prot-Fix		Auto

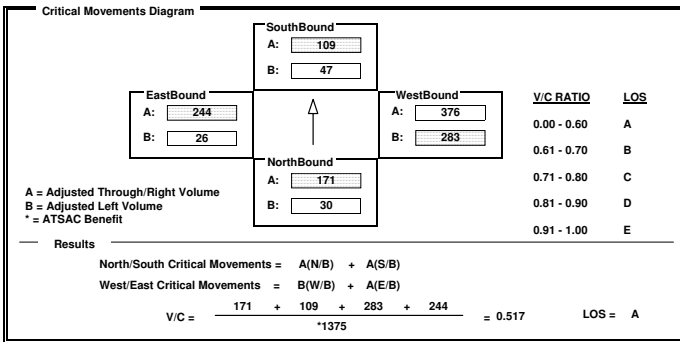

INTERSECTION DATA SUMMARY SHEET

N/S: Airport Blvd W/E: Manchester Ave I/S No: 9
 AM/PM: PM Comments: Existing
 COUNT DATE: STUDY DATE: GROWTH FACTOR:

	NORTHBOUND			SOUTHBOUND			WESTBOUND			EASTBOUND		
	LT	TH	RT	LT	TH	RT	LT	TH	RT	LT	TH	RT
EXISTING	188	703	275	228	327	124	201	842	163	119	1245	161
AMBIENT												
RELATED												
PROJECT												
TOTAL	188	703	275	228	327	124	201	842	163	119	1245	161
LANE	1 2 1			1 1 1			1 2 1			1 2 1		
SIGNAL	Phasing		RTOR	Phasing		RTOR	Phasing		RTOR	Phasing		RTOR
	Prot-Fix		Auto	Prot-Fix		Auto	Prot-Fix		Auto	Prot-Fix		Auto

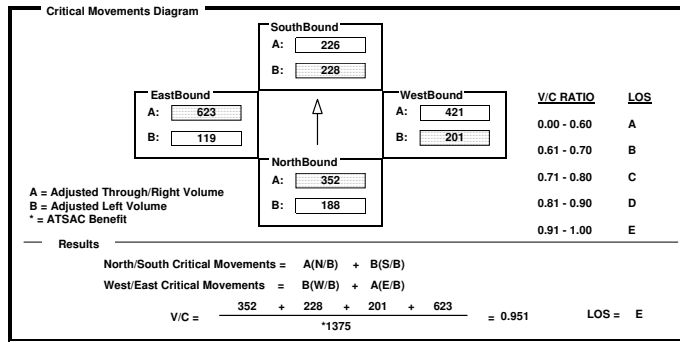

INTERSECTION DATA SUMMARY SHEET

N/S: Aviation Blvd W/E: Arbor Vitae St I/S No: 10
 AM/PM: PM Comments: Existing
 COUNT DATE: STUDY DATE: GROWTH FACTOR:

	NORTHBOUND			SOUTHBOUND			WESTBOUND			EASTBOUND		
	LT	TH	RT	LT	TH	RT	LT	TH	RT	LT	TH	RT
EXISTING	210	622	123	71	405	90	89	380	51	126	745	315
AMBIENT												
RELATED												
PROJECT												
TOTAL	210	622	123	71	405	90	89	380	51	126	745	315
LANE	1 2 1			1 1 1			1 1 1			1 1 1		
SIGNAL	Phasing		RTOR	Phasing		RTOR	Phasing		RTOR	Phasing		RTOR
	Perm		Auto	Perm		Auto	Perm		Auto	Perm		Auto

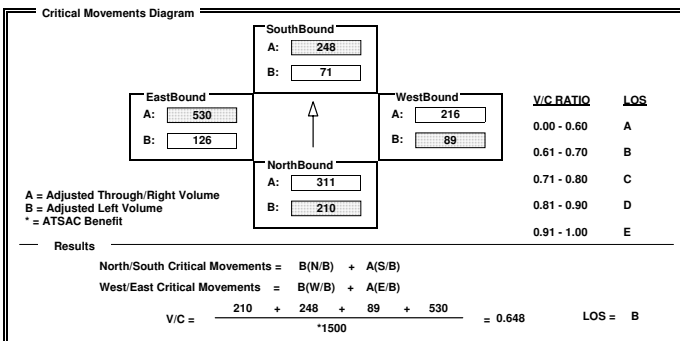

INTERSECTION DATA SUMMARY SHEET

N/S: Aviation Blvd W/E: Century Blvd I/S No: 14
 AM/PM: PM Comments: Existing
 COUNT DATE: STUDY DATE: GROWTH FACTOR:

	NORTHBOUND			SOUTHBOUND			WESTBOUND			EASTBOUND		
	LT	TH	RT	LT	TH	RT	LT	TH	RT	LT	TH	RT
EXISTING	448	655	83	122	523	111	94	1233	112	134	1726	416
AMBIENT												
RELATED												
PROJECT												
TOTAL	448	655	83	122	523	111	94	1233	112	134	1726	416
LANE	2 1 1			2 2 1			1 3 1			1 3 1		
SIGNAL	Phasing		RTOR	Phasing		RTOR	Phasing		RTOR	Phasing		RTOR
	Prot-Fix		Auto	Prot-Fix		OLA	Prot-Fix		Auto	Prot-Fix		Auto

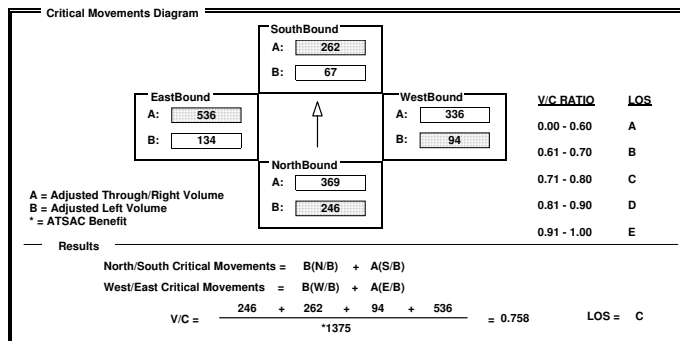

INTERSECTION DATA SUMMARY SHEET

N/S: W/E: I/S No:

AM/PM: Comments:

COUNT DATE: STUDY DATE: GROWTH FACTOR:

Volume/Lane/Signal Configurations

	NORTHBOUND			SOUTHBOUND			WESTBOUND			EASTBOUND		
	LT	TH	RT	LT	TH	RT	LT	TH	RT	LT	TH	RT
EXISTING	185	479	307	404	606	107	236	396	323	227	1084	280
AMBIENT												
RELATED												
PROJECT												
TOTAL	185	479	307	404	606	107	236	396	323	227	1084	280
LANE	[Diagram]			[Diagram]			[Diagram]			[Diagram]		
SIGNAL	Prot-Fix		OLA	Prot-Fix		OLA	Prot-Fix		OLA	Prot-Fix		Auto

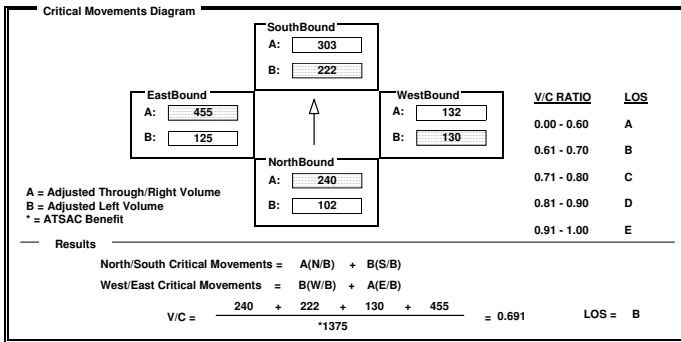

INTERSECTION DATA SUMMARY SHEET

N/S: W/E: I/S No:

AM/PM: Comments:

COUNT DATE: STUDY DATE: GROWTH FACTOR:

Volume/Lane/Signal Configurations

	NORTHBOUND			SOUTHBOUND			WESTBOUND			EASTBOUND		
	LT	TH	RT	LT	TH	RT	LT	TH	RT	LT	TH	RT
EXISTING	144	1423	18	57	1483	336	4	0	27	311	0	60
AMBIENT												
RELATED												
PROJECT												
TOTAL	144	1423	18	57	1483	336	4	0	27	311	0	60
LANE	[Diagram]			[Diagram]			[Diagram]			[Diagram]		
SIGNAL	Prot-Fix		Auto	Prot-Fix		Auto	Prot-Fix		Auto	Prot-Fix		Auto

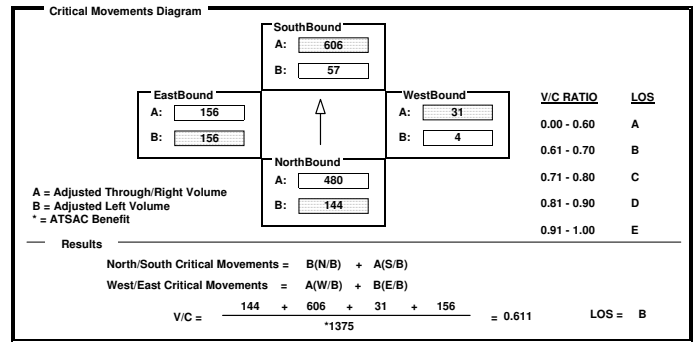

INTERSECTION DATA SUMMARY SHEET

N/S: W/E: I/S No:

AM/PM: Comments:

COUNT DATE: STUDY DATE: GROWTH FACTOR:

Volume/Lane/Signal Configurations

	NORTHBOUND			SOUTHBOUND			WESTBOUND			EASTBOUND		
	LT	TH	RT	LT	TH	RT	LT	TH	RT	LT	TH	RT
EXISTING	0	2114	0	0	2150	0	0	0	0	0	0	0
AMBIENT												
RELATED												
PROJECT												
TOTAL	0	2114	0	0	2150	0	0	0	0	0	0	0
LANE	[Diagram]			[Diagram]			[Diagram]			[Diagram]		
SIGNAL	<none>		Auto	<none>		Auto	<none>		Auto	<none>		Auto

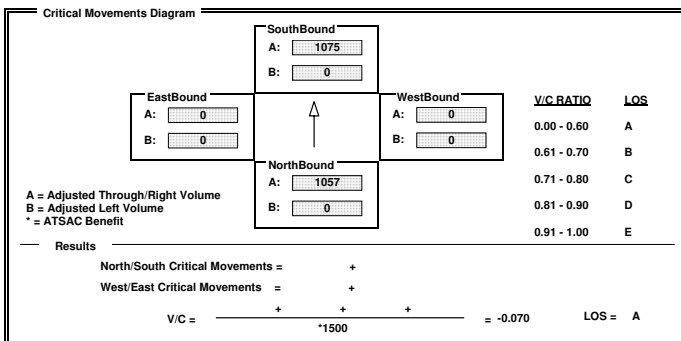

INTERSECTION DATA SUMMARY SHEET

N/S: W/E: I/S No:

AM/PM: Comments:

COUNT DATE: STUDY DATE: GROWTH FACTOR:

Volume/Lane/Signal Configurations

	NORTHBOUND			SOUTHBOUND			WESTBOUND			EASTBOUND		
	LT	TH	RT	LT	TH	RT	LT	TH	RT	LT	TH	RT
EXISTING	189	1079	281	139	916	124	154	692	11	137	656	48
AMBIENT												
RELATED												
PROJECT												
TOTAL	189	1079	281	139	916	124	154	692	11	137	656	48
LANE	[Diagram]			[Diagram]			[Diagram]			[Diagram]		
SIGNAL	Prot-Fix		Auto	Prot-Fix		Auto	Prot-Fix		Auto	Prot-Fix		Auto

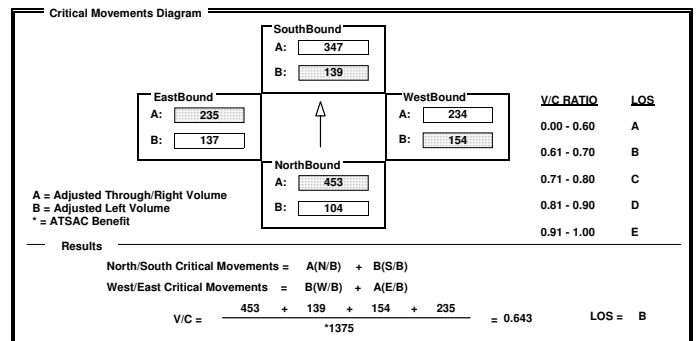

INTERSECTION DATA SUMMARY SHEET

N/S: W/E: I/S No:

AM/PM: Comments:

COUNT DATE: STUDY DATE: GROWTH FACTOR:

	NORTHBOUND			SOUTHBOUND			WESTBOUND			EASTBOUND		
	LT	TH	RT	LT	TH	RT	LT	TH	RT	LT	TH	RT
EXISTING	164	310	625	355	545	440	109	788	233	173	1231	836
AMBIENT												
RELATED												
PROJECT												
TOTAL	164	310	625	355	545	440	109	788	233	173	1231	836
LANE	1	2	2	1	2	2	1	3	1	1	3	1
SIGNAL	Phasing		RTOR	Phasing		RTOR	Phasing		RTOR	Phasing		RTOR
	Prot-Fix		OLA	Prot-Fix		OLA	Prot-Fix		Auto	Prot-Fix		OLA

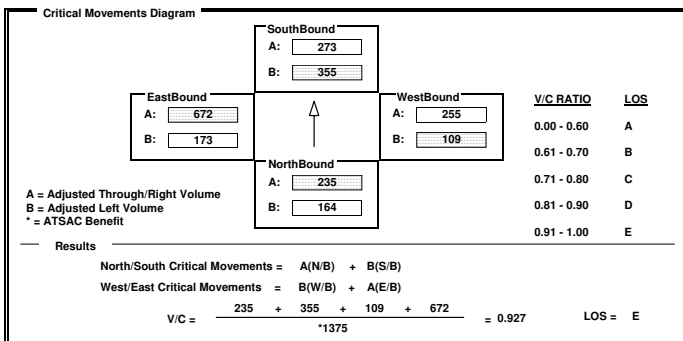

INTERSECTION DATA SUMMARY SHEET

N/S: W/E: I/S No:

AM/PM: Comments:

COUNT DATE: STUDY DATE: GROWTH FACTOR:

	NORTHBOUND			SOUTHBOUND			WESTBOUND			EASTBOUND		
	LT	TH	RT	LT	TH	RT	LT	TH	RT	LT	TH	RT
EXISTING	0	3438	17	0	2226	241	556	26	300	0	0	0
AMBIENT												
RELATED												
PROJECT												
TOTAL	0	3438	17	0	2226	241	556	26	300	0	0	0
LANE		4	1		4	1	1	1	2			
SIGNAL	Phasing		RTOR	Phasing		RTOR	Phasing		RTOR	Phasing		RTOR
	Perm		Free	Perm		Auto	Split		Auto	<none>		Auto

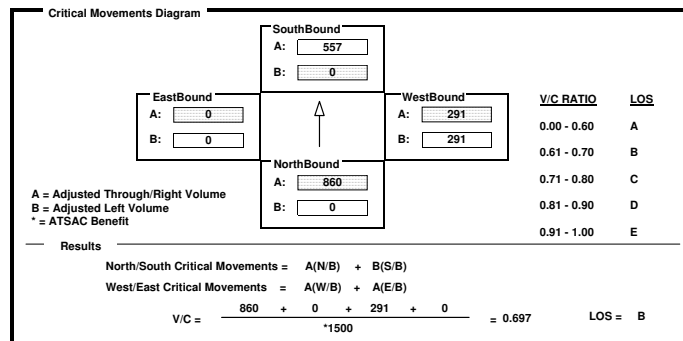

INTERSECTION DATA SUMMARY SHEET

N/S: W/E: I/S No:

AM/PM: Comments:

COUNT DATE: STUDY DATE: GROWTH FACTOR:

	NORTHBOUND			SOUTHBOUND			WESTBOUND			EASTBOUND		
	LT	TH	RT	LT	TH	RT	LT	TH	RT	LT	TH	RT
EXISTING	167	14	444	73	8	38	30	595	32	36	1029	42
AMBIENT												
RELATED												
PROJECT												
TOTAL	167	14	444	73	8	38	30	595	32	36	1029	42
LANE	1	1	2	1	1	1	2	2	1	1	2	1
SIGNAL	Phasing		RTOR	Phasing		RTOR	Phasing		RTOR	Phasing		RTOR
	Split		OLA	Split		Auto	Prot-Fix		Auto	Prot-Fix		Auto

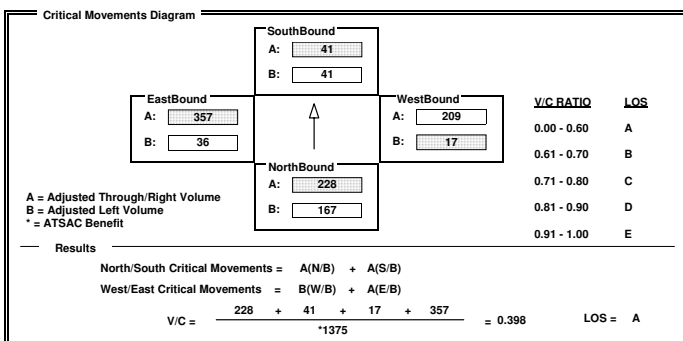

INTERSECTION DATA SUMMARY SHEET

N/S: W/E: I/S No:

AM/PM: Comments:

COUNT DATE: STUDY DATE: GROWTH FACTOR:

	NORTHBOUND			SOUTHBOUND			WESTBOUND			EASTBOUND		
	LT	TH	RT	LT	TH	RT	LT	TH	RT	LT	TH	RT
EXISTING	684	1820	24	74	1548	115	46	14	32	119	21	979
AMBIENT												
RELATED												
PROJECT												
TOTAL	684	1820	24	74	1548	115	46	14	32	119	21	979
LANE	2	2	1	1	2	1	1	1	1	1	1	1
SIGNAL	Phasing		RTOR	Phasing		RTOR	Phasing		RTOR	Phasing		RTOR
	Prot-Fix		Auto	Prot-Fix		Auto	Perm		Auto	Perm		Free

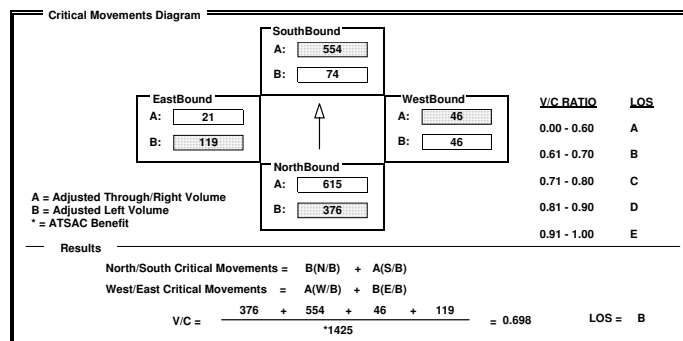

INTERSECTION DATA SUMMARY SHEET

N/S: Sepulveda Blvd W/E: Howard Hughes Pkwy I/S No: 65
AM/PM: PM Comments: Existing
COUNT DATE: STUDY DATE: GROWTH FACTOR:

Volume/Lane/Signal Configurations table with columns for Northbound, Southbound, Westbound, Eastbound and rows for Existing, Ambient, Related, Project, Total, Lane, and Signal.

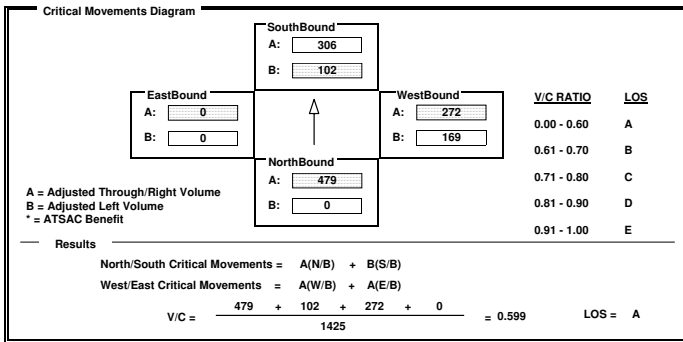

INTERSECTION DATA SUMMARY SHEET

N/S: La Cienega Blvd W/E: Imperial Hwy I/S No: 67
AM/PM: PM Comments: Existing
COUNT DATE: STUDY DATE: GROWTH FACTOR:

Volume/Lane/Signal Configurations table with columns for Northbound, Southbound, Westbound, Eastbound and rows for Existing, Ambient, Related, Project, Total, Lane, and Signal.

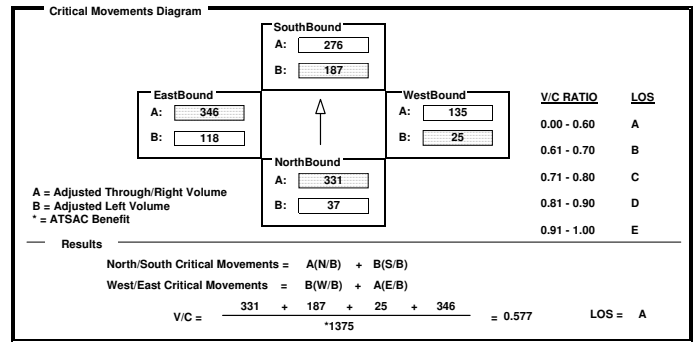

INTERSECTION DATA SUMMARY SHEET

N/S: Sepulveda Blvd W/E: Imperial Hwy I/S No: 71
AM/PM: PM Comments: Existing
COUNT DATE: STUDY DATE: GROWTH FACTOR:

Volume/Lane/Signal Configurations table with columns for Northbound, Southbound, Westbound, Eastbound and rows for Existing, Ambient, Related, Project, Total, Lane, and Signal.

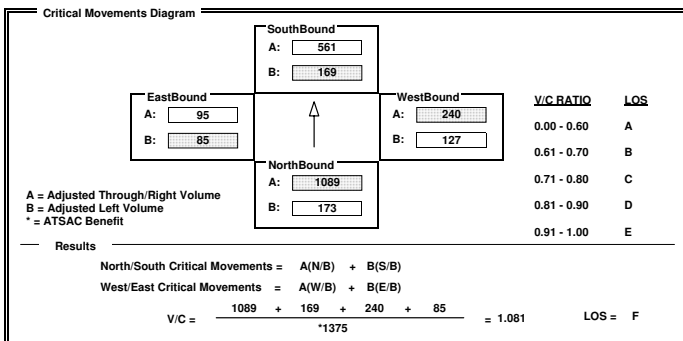

INTERSECTION DATA SUMMARY SHEET

N/S: 105 WB Off Ramps/Nash St W/E: Imperial Hwy I/S No: 73
AM/PM: PM Comments: Existing
COUNT DATE: STUDY DATE: GROWTH FACTOR:

Volume/Lane/Signal Configurations table with columns for Northbound, Southbound, Westbound, Eastbound and rows for Existing, Ambient, Related, Project, Total, Lane, and Signal.

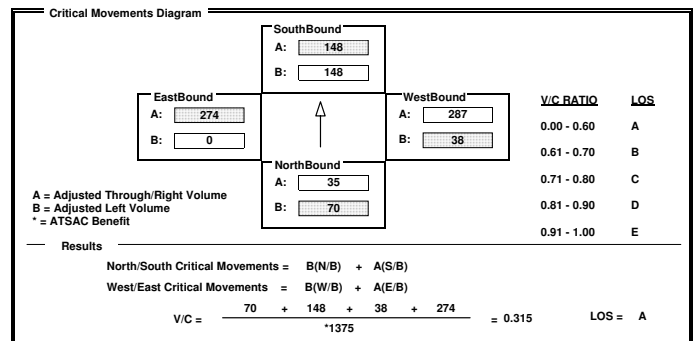

INTERSECTION DATA SUMMARY SHEET

N/S: 105 EB On Ramps W/E: Imperial Hwy I/S No: 74
 AM/PM: PM Comments: Existing
 COUNT DATE: STUDY DATE: GROWTH FACTOR:

	NORTHBOUND			SOUTHBOUND			WESTBOUND			EASTBOUND		
	LT	TH	RT	LT	TH	RT	LT	TH	RT	LT	TH	RT
EXISTING	436	0	515	0	0	0	258	614	0	0	957	789
AMBIENT												
RELATED												
PROJECT												
TOTAL	436	0	515	0	0	0	258	614	0	0	957	789
LANE	2		2				2	2			2	1
SIGNAL	Phasing: Split	RTOR: OLA	Phasing: <none>	RTOR: <none>	Phasing: Prot-Fix	RTOR: Auto	Phasing: Perm	RTOR: OLA				

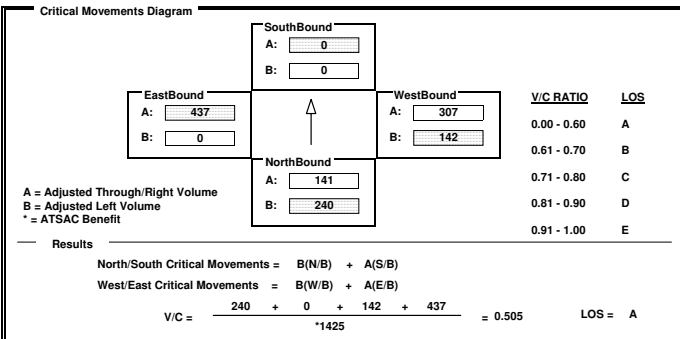

INTERSECTION DATA SUMMARY SHEET

N/S: Lincoln Blvd W/E: Jefferson Blvd I/S No: 78
 AM/PM: PM Comments: Existing
 COUNT DATE: STUDY DATE: GROWTH FACTOR:

	NORTHBOUND			SOUTHBOUND			WESTBOUND			EASTBOUND		
	LT	TH	RT	LT	TH	RT	LT	TH	RT	LT	TH	RT
EXISTING	39	1686	389	400	1628	545	484	434	478	59	183	38
AMBIENT												
RELATED												
PROJECT												
TOTAL	39	1686	389	400	1628	545	484	434	478	59	183	38
LANE	1	2	1	2	2	1	2	2	2	1	1	1
SIGNAL	Phasing: Prot-Fix	RTOR: OLA	Phasing: Prot-Fix	RTOR: OLA	Phasing: Prot-Fix	RTOR: OLA	Phasing: Prot-Fix	RTOR: OLA	Phasing: Prot-Fix	RTOR: Auto		

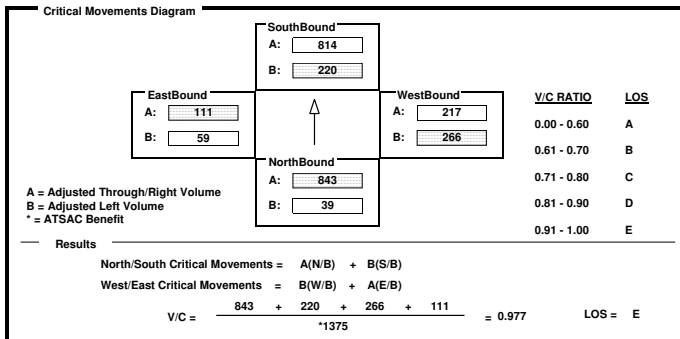

INTERSECTION DATA SUMMARY SHEET

N/S: La Cienega Blvd W/E: La Tijera Blvd I/S No: 88
 AM/PM: PM Comments: Existing
 COUNT DATE: STUDY DATE: GROWTH FACTOR:

	NORTHBOUND			SOUTHBOUND			WESTBOUND			EASTBOUND		
	LT	TH	RT	LT	TH	RT	LT	TH	RT	LT	TH	RT
EXISTING	0	2270	208	0	2703	1241	0	0	0	1066	251	19
AMBIENT												
RELATED												
PROJECT												
TOTAL	0	2270	208	0	2703	1241	0	0	0	1066	251	19
LANE		2	1		2	1				3		1
SIGNAL	Phasing: Perm	RTOR: Auto	Phasing: Perm	RTOR: OLA	Phasing: <none>	RTOR: <none>	Phasing: Split	RTOR: Auto				

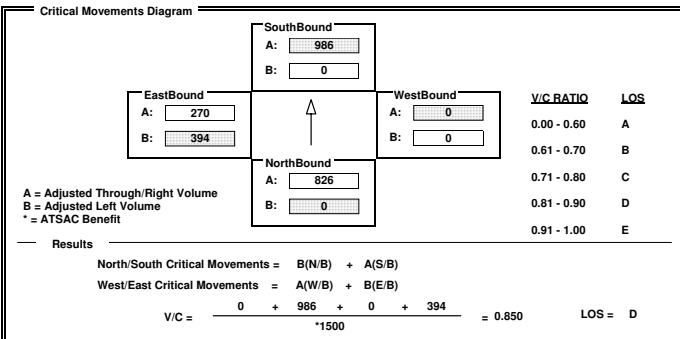

INTERSECTION DATA SUMMARY SHEET

N/S: Lincoln Blvd W/E: La Tijera Blvd I/S No: 99
 AM/PM: PM Comments: Existing
 COUNT DATE: STUDY DATE: GROWTH FACTOR:

	NORTHBOUND			SOUTHBOUND			WESTBOUND			EASTBOUND		
	LT	TH	RT	LT	TH	RT	LT	TH	RT	LT	TH	RT
EXISTING	34	1664	18	37	1635	18	14	5	5	24	12	51
AMBIENT												
RELATED												
PROJECT												
TOTAL	34	1664	18	37	1635	18	14	5	5	24	12	51
LANE	1	2	1	1	2	1				1	1	1
SIGNAL	Phasing: Prot-Fix	RTOR: Auto	Phasing: Prot-Fix	RTOR: Auto	Phasing: Perm	RTOR: Auto	Phasing: Perm	RTOR: OLA				

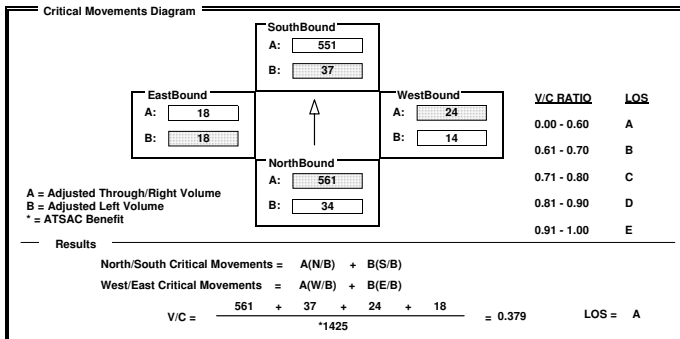

INTERSECTION DATA SUMMARY SHEET

N/S: W/E: I/S No:

AM/PM: Comments:

COUNT DATE: STUDY DATE: GROWTH FACTOR:

Volume/Lane/Signal Configurations

	NORTHBOUND			SOUTHBOUND			WESTBOUND			EASTBOUND		
	LT	TH	RT	LT	TH	RT	LT	TH	RT	LT	TH	RT
EXISTING	157	231	378	174	220	323	268	745	164	334	983	172
AMBIENT												
RELATED												
PROJECT												
TOTAL	157	231	378	174	220	323	268	745	164	334	983	172
LANE	1	2	1	1	2	1	1	2	1	1	2	1
SIGNAL	Phasing: Perm	RTOR: Auto		Phasing: Perm	RTOR: Auto		Phasing: Prot-Fix	RTOR: Auto		Phasing: Prot-Fix	RTOR: Free	

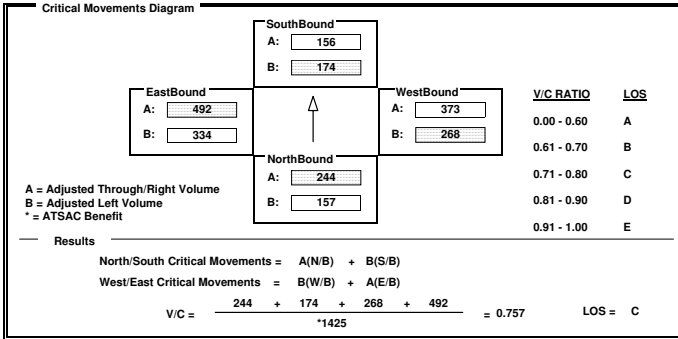

INTERSECTION DATA SUMMARY SHEET

N/S: W/E: I/S No:

AM/PM: Comments:

COUNT DATE: STUDY DATE: GROWTH FACTOR:

Volume/Lane/Signal Configurations

	NORTHBOUND			SOUTHBOUND			WESTBOUND			EASTBOUND		
	LT	TH	RT	LT	TH	RT	LT	TH	RT	LT	TH	RT
EXISTING	140	1535	150	64	1190	79	201	383	58	87	440	70
AMBIENT												
RELATED												
PROJECT												
TOTAL	140	1535	150	64	1190	79	201	383	58	87	440	70
LANE	1	3	1	1	3	1	1	2	1	1	2	1
SIGNAL	Phasing: Perm	RTOR: Auto		Phasing: Perm	RTOR: Auto		Phasing: Perm	RTOR: Auto		Phasing: Perm	RTOR: Auto	

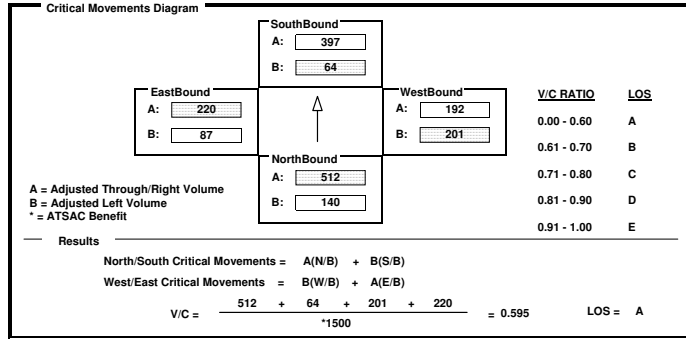

INTERSECTION DATA SUMMARY SHEET

N/S: W/E: I/S No:

AM/PM: Comments:

COUNT DATE: STUDY DATE: GROWTH FACTOR:

Volume/Lane/Signal Configurations

	NORTHBOUND			SOUTHBOUND			WESTBOUND			EASTBOUND		
	LT	TH	RT	LT	TH	RT	LT	TH	RT	LT	TH	RT
EXISTING	177	0	245	0	0	0	0	1062	110	285	1325	0
AMBIENT												
RELATED												
PROJECT												
TOTAL	177	0	245	0	0	0	0	1062	110	285	1325	0
LANE	1		1					3	1	1	3	
SIGNAL	Phasing: Split	RTOR: Auto		Phasing: <none>	RTOR: <none>		Phasing: Perm	RTOR: Auto		Phasing: Prot-Fix	RTOR: <none>	

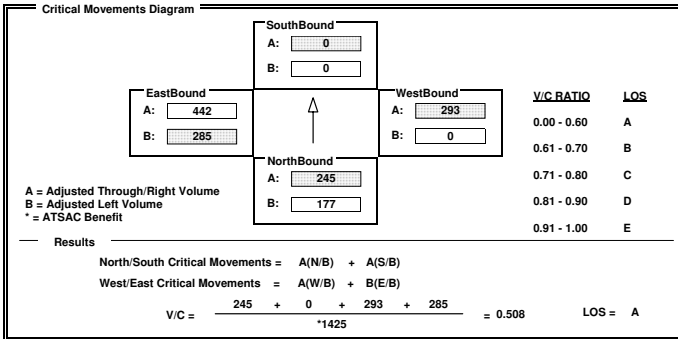

INTERSECTION DATA SUMMARY SHEET

N/S: W/E: I/S No:

AM/PM: Comments:

COUNT DATE: STUDY DATE: GROWTH FACTOR:

Volume/Lane/Signal Configurations

	NORTHBOUND			SOUTHBOUND			WESTBOUND			EASTBOUND		
	LT	TH	RT	LT	TH	RT	LT	TH	RT	LT	TH	RT
EXISTING	0	0	0	309	0	368	373	866	0	0	1301	190
AMBIENT												
RELATED												
PROJECT												
TOTAL	0	0	0	309	0	368	373	866	0	0	1301	190
LANE										1	3	1
SIGNAL	Phasing: <none>	RTOR: <none>		Phasing: Split	RTOR: <none>		Phasing: Prot-Fix	RTOR: <none>		Phasing: Perm	RTOR: Auto	

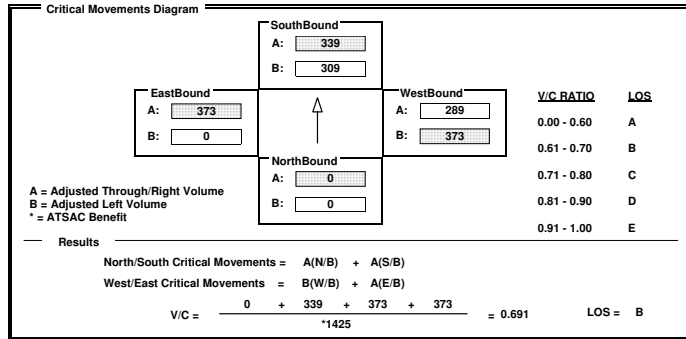

INTERSECTION DATA SUMMARY SHEET

N/S: Lincoln Blvd W/E: LMU Dr I/S No: 104
 AM/PM: PM Comments: Existing
 COUNT DATE: STUDY DATE: GROWTH FACTOR:

	NORTHBOUND			SOUTHBOUND			WESTBOUND			EASTBOUND		
	LT	TH	RT	LT	TH	RT	LT	TH	RT	LT	TH	RT
EXISTING	12	1973	81	65	2051	34	158	0	128	13	9	26
AMBIENT												
RELATED												
PROJECT												
TOTAL	12	1973	81	65	2051	34	158	0	128	13	9	26
LANE	1	2	1	2	2	1	1	1	1	1	1	1
SIGNAL	Prot-Fix	Auto	Prot-Fix	Auto	Perm	Auto	Perm	Auto	Perm	Auto	Perm	Auto

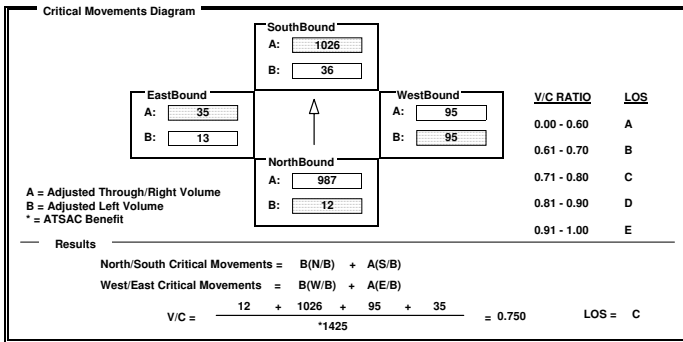

INTERSECTION DATA SUMMARY SHEET

N/S: Lincoln Blvd W/E: Manchester Blvd I/S No: 105
 AM/PM: PM Comments: Existing
 COUNT DATE: STUDY DATE: GROWTH FACTOR:

	NORTHBOUND			SOUTHBOUND			WESTBOUND			EASTBOUND		
	LT	TH	RT	LT	TH	RT	LT	TH	RT	LT	TH	RT
EXISTING	72	1581	212	207	1488	50	172	314	237	98	258	78
AMBIENT												
RELATED												
PROJECT												
TOTAL	72	1581	212	207	1488	50	172	314	237	98	258	78
LANE	1	2	1	1	2	1	1	2	1	1	2	1
SIGNAL	Prot-Fix	Auto	Prot-Fix	Auto	Prot-Fix	OLA	Prot-Fix	Auto	Prot-Fix	Auto	Prot-Fix	Auto

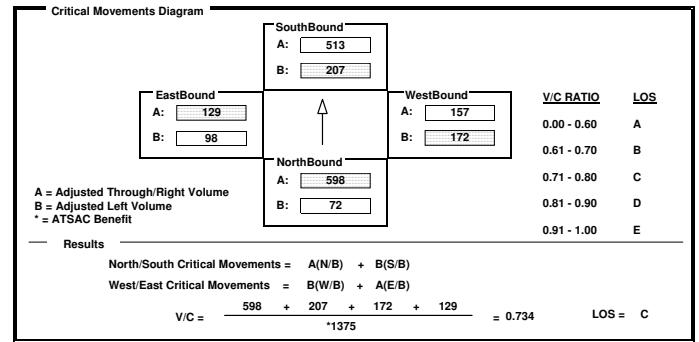

INTERSECTION DATA SUMMARY SHEET

N/S: Lincoln Blvd W/E: Marina Pointe Dr/ Maxella Ave I/S No: 106
 AM/PM: PM Comments: Existing
 COUNT DATE: STUDY DATE: GROWTH FACTOR:

	NORTHBOUND			SOUTHBOUND			WESTBOUND			EASTBOUND		
	LT	TH	RT	LT	TH	RT	LT	TH	RT	LT	TH	RT
EXISTING	344	1775	249	223	2175	66	218	94	249	63	57	68
AMBIENT												
RELATED												
PROJECT												
TOTAL	344	1775	249	223	2175	66	218	94	249	63	57	68
LANE	2	3	1	2	3	1	1	1	1	1	1	1
SIGNAL	Prot-Fix	OLA	Prot-Fix	Auto	Perm	OLA	Perm	OLA	Perm	OLA	Perm	OLA

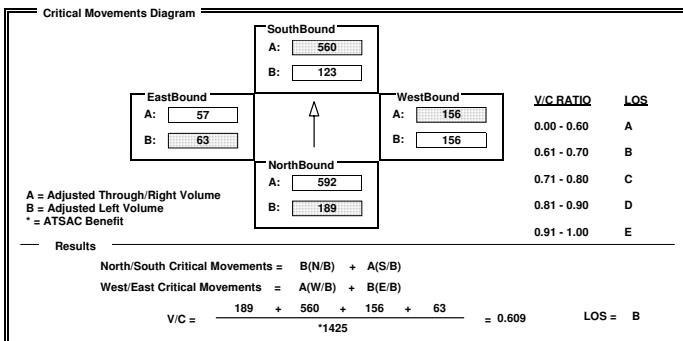

INTERSECTION DATA SUMMARY SHEET

N/S: Lincoln Blvd W/E: Mindanao Way I/S No: 107
 AM/PM: PM Comments: Existing
 COUNT DATE: STUDY DATE: GROWTH FACTOR:

	NORTHBOUND			SOUTHBOUND			WESTBOUND			EASTBOUND		
	LT	TH	RT	LT	TH	RT	LT	TH	RT	LT	TH	RT
EXISTING	86	1598	277	191	1198	94	347	628	54	2	482	104
AMBIENT												
RELATED												
PROJECT												
TOTAL	86	1598	277	191	1198	94	347	628	54	2	482	104
LANE	1	3	1	1	2	1	2	1	1	1	1	1
SIGNAL	Prot-Fix	Auto	Prot-Fix	Auto	Prot-Fix	Auto	Prot-Fix	Auto	Perm	Auto	Perm	Auto

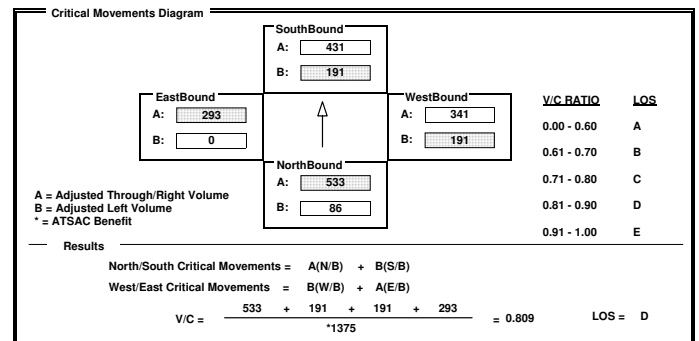

INTERSECTION DATA SUMMARY SHEET

N/S: Sepulveda Blvd W/E: Lincoln Blvd I/S No: 108
AM/PM: PM Comments: Existing
COUNT DATE: STUDY DATE: GROWTH FACTOR:

Volume/Lane/Signal Configurations table with columns for Northbound, Southbound, Westbound, Eastbound and rows for Existing, Ambient, Related, Project, Total, Lane, Phasing, RTOR, Signal.

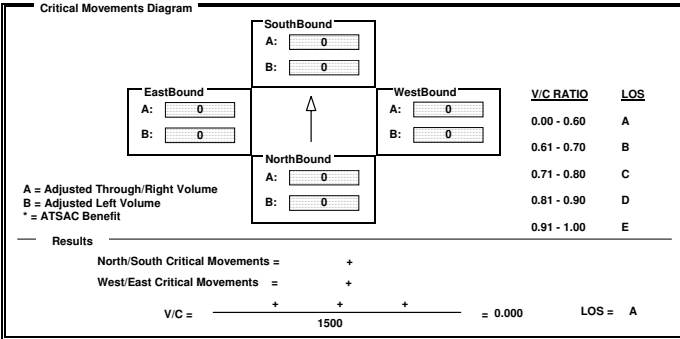

INTERSECTION DATA SUMMARY SHEET

N/S: Lincoln Blvd W/E: Venice Blvd I/S No: 109
AM/PM: PM Comments: Existing
COUNT DATE: STUDY DATE: GROWTH FACTOR:

Volume/Lane/Signal Configurations table with columns for Northbound, Southbound, Westbound, Eastbound and rows for Existing, Ambient, Related, Project, Total, Lane, Phasing, RTOR, Signal.

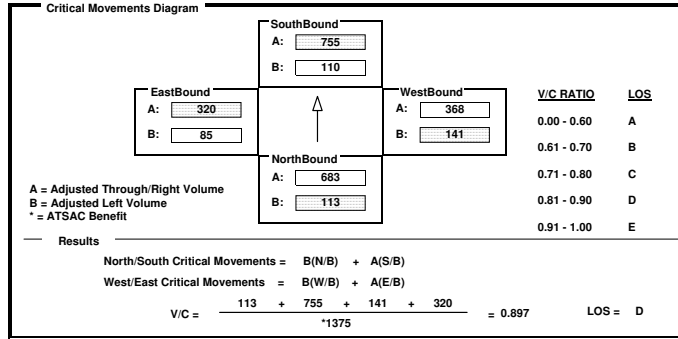

INTERSECTION DATA SUMMARY SHEET

N/S: Lincoln Blvd W/E: Washington Blvd I/S No: 110
AM/PM: PM Comments: Existing
COUNT DATE: STUDY DATE: GROWTH FACTOR:

Volume/Lane/Signal Configurations table with columns for Northbound, Southbound, Westbound, Eastbound and rows for Existing, Ambient, Related, Project, Total, Lane, Phasing, RTOR, Signal.

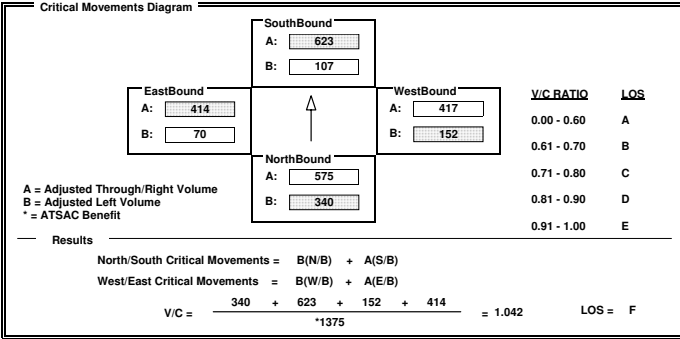

INTERSECTION DATA SUMMARY SHEET

N/S: Lincoln Blvd W/E: 83rd St I/S No: 111
AM/PM: PM Comments: Existing
COUNT DATE: STUDY DATE: GROWTH FACTOR:

Volume/Lane/Signal Configurations table with columns for Northbound, Southbound, Westbound, Eastbound and rows for Existing, Ambient, Related, Project, Total, Lane, Phasing, RTOR, Signal.

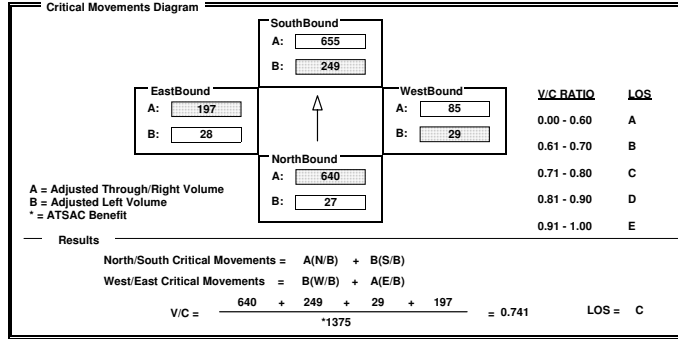

INTERSECTION DATA SUMMARY SHEET

N/S: Sepulveda Blvd W/E: Manchester Ave I/S No: 114
 AM/PM: PM Comments: Existing
 COUNT DATE: STUDY DATE: GROWTH FACTOR:

	NORTHBOUND			SOUTHBOUND			WESTBOUND			EASTBOUND		
	LT	TH	RT	LT	TH	RT	LT	TH	RT	LT	TH	RT
EXISTING	107	1355	84	238	1199	261	89	835	188	209	991	97
AMBIENT												
RELATED												
PROJECT												
TOTAL	107	1355	84	238	1199	261	89	835	188	209	991	97
LANE	1 3 1	1 3 1	1 3 1	1 2 1	1 2 1	1 2 1	2 2 1	2 2 1	1 1 1	1 1 1	1 1 1	1 1 1
Phasing	Prot-Fix		Auto	Prot-Fix		Auto	Prot-Fix		Auto	Prot-Fix		Auto
RTOR	Auto		Auto	Auto		Auto	Auto		Auto	Auto		Auto
SIGNAL	Prot-Fix		Auto	Prot-Fix		Auto	Prot-Fix		Auto	Prot-Fix		Auto

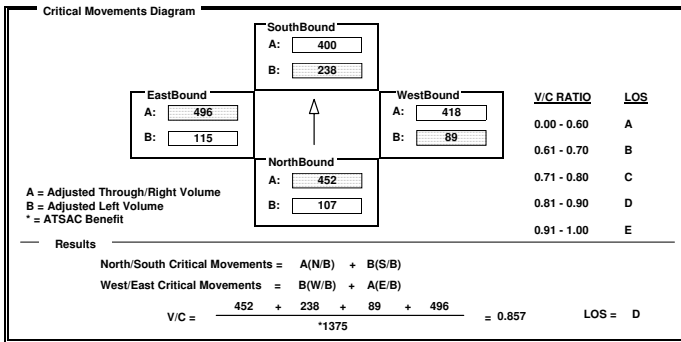

INTERSECTION DATA SUMMARY SHEET

N/S: Sepulveda Blvd W/E: Westchester Pkwy I/S No: 135
 AM/PM: PM Comments: Existing
 COUNT DATE: STUDY DATE: GROWTH FACTOR:

	NORTHBOUND			SOUTHBOUND			WESTBOUND			EASTBOUND		
	LT	TH	RT	LT	TH	RT	LT	TH	RT	LT	TH	RT
EXISTING	194	1504	71	145	1366	44	173	323	127	65	215	99
AMBIENT												
RELATED												
PROJECT												
TOTAL	194	1504	71	145	1366	44	173	323	127	65	215	99
LANE	1 2 1	1 2 1	1 2 1	1 2 1	1 2 1	1 2 1	1 1 1	1 1 1	1 1 1	1 2 1	1 1 1	1 1 1
Phasing	Prot-Fix		Auto	Prot-Fix		Auto	Prot-Fix		Auto	Prot-Fix		Auto
RTOR	Auto		Auto	Auto		Auto	Auto		Auto	Auto		Auto
SIGNAL	Prot-Fix		Auto	Prot-Fix		Auto	Prot-Fix		Auto	Prot-Fix		Auto

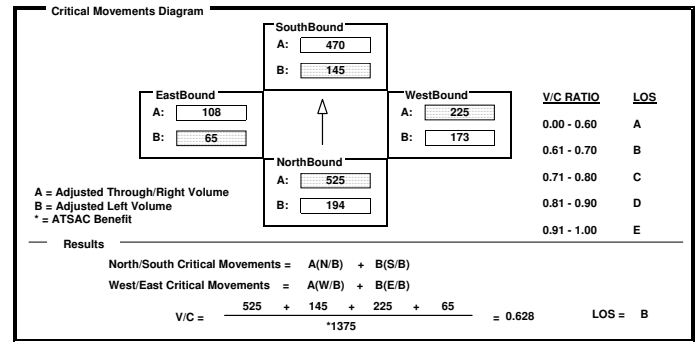

INTERSECTION DATA SUMMARY SHEET

N/S: Sepulveda Blvd W/E: 76th St/77th St I/S No: 136
 AM/PM: PM Comments: Existing
 COUNT DATE: STUDY DATE: GROWTH FACTOR:

	NORTHBOUND			SOUTHBOUND			WESTBOUND			EASTBOUND		
	LT	TH	RT	LT	TH	RT	LT	TH	RT	LT	TH	RT
EXISTING	42	1825	28	121	1997	343	35	63	85	196	63	67
AMBIENT												
RELATED												
PROJECT												
TOTAL	42	1825	28	121	1997	343	35	63	85	196	63	67
LANE	1 3 1	1 3 1	1 3 1	1 2 1	1 2 1	1 2 1	1 1 1	1 1 1	1 1 1	2 1 1	1 1 1	1 1 1
Phasing	Perm		Auto	Perm		Auto	Perm		Auto	Perm		Auto
RTOR	Auto		Auto	Auto		Auto	Auto		Auto	Auto		Auto
SIGNAL	Perm		Auto	Perm		Auto	Perm		Auto	Perm		Auto

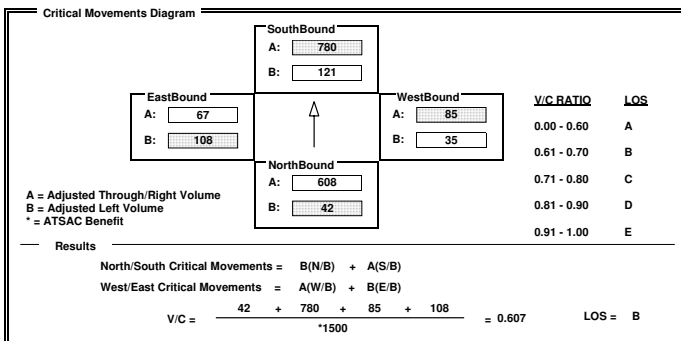

INTERSECTION DATA SUMMARY SHEET

N/S: Sepulveda Blvd W/E: 79 St/80th St I/S No: 137
 AM/PM: PM Comments: Existing
 COUNT DATE: STUDY DATE: GROWTH FACTOR:

	NORTHBOUND			SOUTHBOUND			WESTBOUND			EASTBOUND		
	LT	TH	RT	LT	TH	RT	LT	TH	RT	LT	TH	RT
EXISTING	97	1690	12	65	1693	232	42	72	27	112	82	80
AMBIENT												
RELATED												
PROJECT												
TOTAL	97	1690	12	65	1693	232	42	72	27	112	82	80
LANE	1 2 1	1 2 1	1 2 1	1 3 1	1 3 1	1 3 1	1 1 1	1 1 1	1 1 1	1 1 1	1 1 1	1 1 1
Phasing	Perm		Auto	Perm		Auto	Perm		Auto	Perm		Auto
RTOR	Auto		Auto	Auto		Auto	Auto		Auto	Auto		Auto
SIGNAL	Perm		Auto	Perm		Auto	Perm		Auto	Perm		Auto

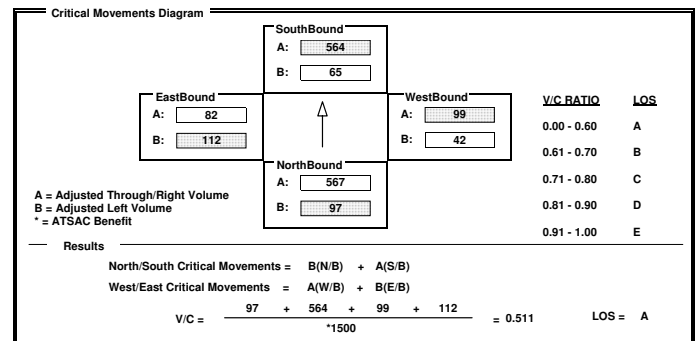

INTERSECTION DATA SUMMARY SHEET

N/S: Sepulveda Blvd W/E: 83rd St I/S No: 138
AM/PM: PM Comments: Existing
COUNT DATE: STUDY DATE: GROWTH FACTOR:

Volume/Lane/Signal Configurations table with columns for Northbound, Southbound, Westbound, Eastbound and rows for Existing, Ambient, Related, Project, Total, Lane, Phasing, RTOR, Signal.

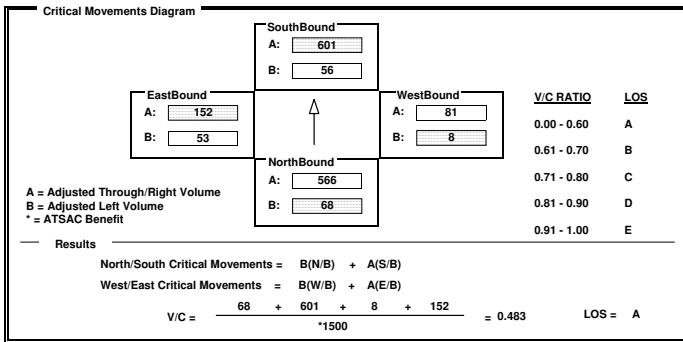

INTERSECTION DATA SUMMARY SHEET

N/S: Sepulveda Blvd W/E: I-105 WB Ramp I/S No: 139
AM/PM: PM Comments: Existing
COUNT DATE: STUDY DATE: GROWTH FACTOR:

Volume/Lane/Signal Configurations table with columns for Northbound, Southbound, Westbound, Eastbound and rows for Existing, Ambient, Related, Project, Total, Lane, Phasing, RTOR, Signal.

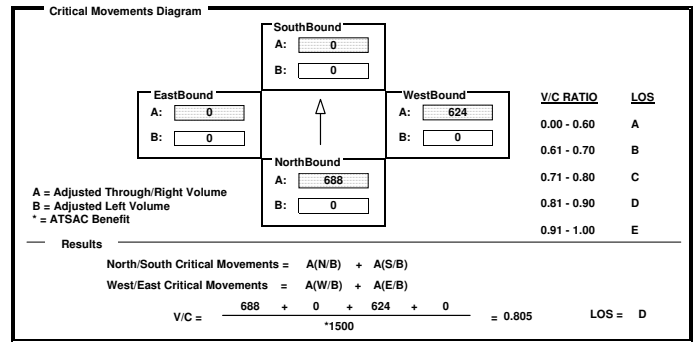

INTERSECTION DATA SUMMARY SHEET

N/S: Airport Blvd W/E: 96th St I/S No: 141
AM/PM: PM Comments: Existing
COUNT DATE: STUDY DATE: GROWTH FACTOR:

Volume/Lane/Signal Configurations table with columns for Northbound, Southbound, Westbound, Eastbound and rows for Existing, Ambient, Related, Project, Total, Lane, Phasing, RTOR, Signal.

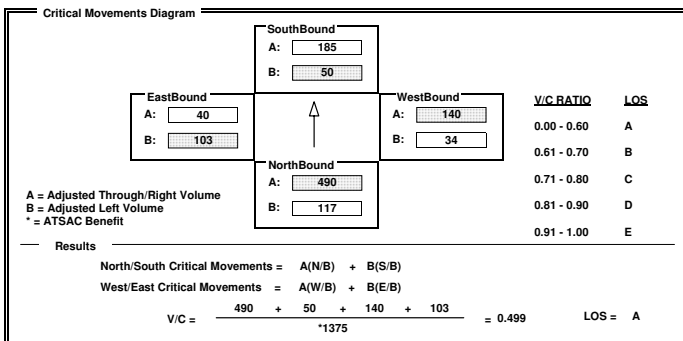

INTERSECTION DATA SUMMARY SHEET

N/S: Airport Blvd W/E: 98 St I/S No: 144
AM/PM: PM Comments: Existing
COUNT DATE: STUDY DATE: GROWTH FACTOR:

Volume/Lane/Signal Configurations table with columns for Northbound, Southbound, Westbound, Eastbound and rows for Existing, Ambient, Related, Project, Total, Lane, Phasing, RTOR, Signal.

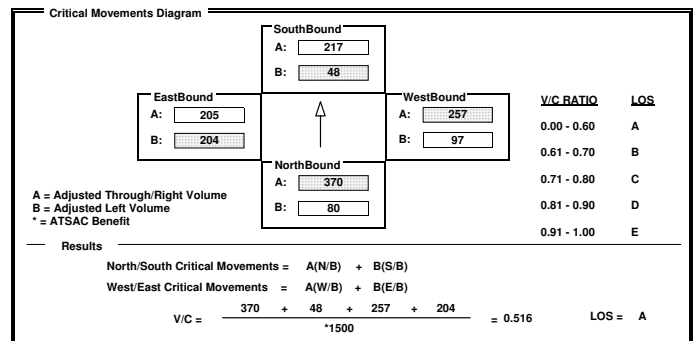

INTERSECTION DATA SUMMARY SHEET

N/S: W/E: I/S No:

AM/PM: Comments:

COUNT DATE: STUDY DATE: GROWTH FACTOR:

	NORTHBOUND			SOUTHBOUND			WESTBOUND			EASTBOUND		
	LT	TH	RT	LT	TH	RT	LT	TH	RT	LT	TH	RT
EXISTING	25	188	123	211	21	93	20	452	128	56	336	6
AMBIENT												
RELATED												
PROJECT												
TOTAL	25	188	123	211	21	93	20	452	128	56	336	6
LANE	1 1 1			1 1 1			1 1 1			1 1 1		
SIGNAL	Phasing		RTOR	Phasing		RTOR	Phasing		RTOR	Phasing		RTOR
	Perm		Auto	Perm		Auto	Perm		Auto	Perm		Auto

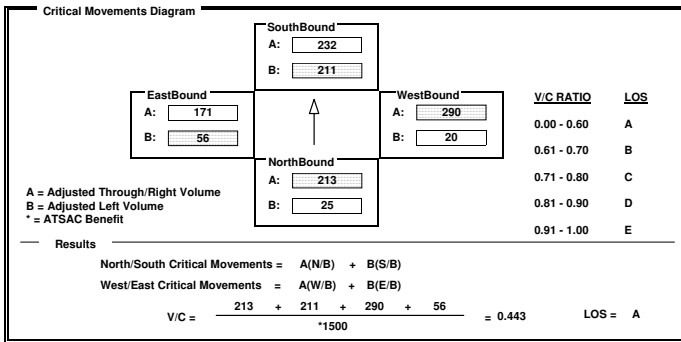

INTERSECTION DATA SUMMARY SHEET

N/S: W/E: I/S No:

AM/PM: Comments:

COUNT DATE: STUDY DATE: GROWTH FACTOR:

	NORTHBOUND			SOUTHBOUND			WESTBOUND			EASTBOUND		
	LT	TH	RT	LT	TH	RT	LT	TH	RT	LT	TH	RT
EXISTING	0	600	79	180	764	0	663	0	164	0	0	0
AMBIENT												
RELATED												
PROJECT												
TOTAL	0	600	79	180	764	0	663	0	164	0	0	0
LANE	1 1 1			1 2			1 1 1			1 1 1		
SIGNAL	Phasing		RTOR	Phasing		RTOR	Phasing		RTOR	Phasing		RTOR
	Perm		OLA	Prot-Fix		Auto	Split		OLA	Split		Auto

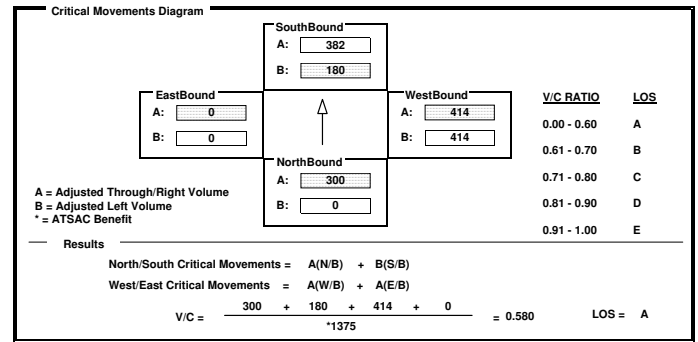

INTERSECTION DATA SUMMARY SHEET

N/S: W/E: I/S No:

AM/PM: Comments:

COUNT DATE: STUDY DATE: GROWTH FACTOR:

	NORTHBOUND			SOUTHBOUND			WESTBOUND			EASTBOUND		
	LT	TH	RT	LT	TH	RT	LT	TH	RT	LT	TH	RT
EXISTING	0	636	33	662	928	0	0	0	476	0	0	0
AMBIENT												
RELATED												
PROJECT												
TOTAL	0	636	33	662	928	0	0	0	476	0	0	0
LANE	1 1 1			2 2			2			2		
SIGNAL	Phasing		RTOR	Phasing		RTOR	Phasing		RTOR	Phasing		RTOR
	Perm		Auto	Prot-Fix		Auto	Split		OLA	Split		Auto

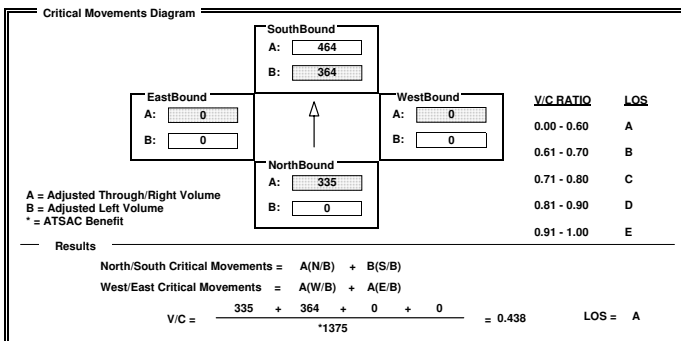

INTERSECTION DATA SUMMARY SHEET

N/S: W/E: I/S No:

AM/PM: Comments:

COUNT DATE: STUDY DATE: GROWTH FACTOR:

	NORTHBOUND			SOUTHBOUND			WESTBOUND			EASTBOUND		
	LT	TH	RT	LT	TH	RT	LT	TH	RT	LT	TH	RT
EXISTING	127	2455	171	175	2427	17	129	698	94	0	994	145
AMBIENT												
RELATED												
PROJECT												
TOTAL	127	2455	171	175	2427	17	129	698	94	0	994	145
LANE	2 2 1			1 2 1			1 2 1			2 1 1		
SIGNAL	Phasing		RTOR	Phasing		RTOR	Phasing		RTOR	Phasing		RTOR
	Prot-Fix		Auto	Prot-Fix		Auto	Prot-Fix		Auto	Perm		Auto

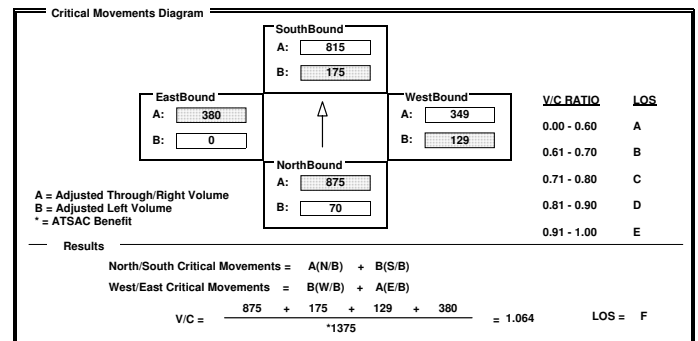

INTERSECTION DATA SUMMARY SHEET

N/S: W/E: I/S No:

AM/PM: Comments:

COUNT DATE: STUDY DATE: GROWTH FACTOR:

Volume/Lane/Signal Configurations

	NORTHBOUND			SOUTHBOUND			WESTBOUND			EASTBOUND		
	LT	TH	RT	LT	TH	RT	LT	TH	RT	LT	TH	RT
EXISTING	60	1456	109	104	1311	98	327	1326	103	116	1092	69
AMBIENT												
RELATED												
PROJECT												
TOTAL	60	1456	109	104	1311	98	327	1326	103	116	1092	69
LANE	1	2	1	1	2	1	1	2	1	1	2	1
SIGNAL	Phasing: Prot-Fix	RTOR: Auto		Phasing: Prot-Fix	RTOR: Auto		Phasing: Prot-Fix	RTOR: Auto		Phasing: Prot-Fix	RTOR: Auto	

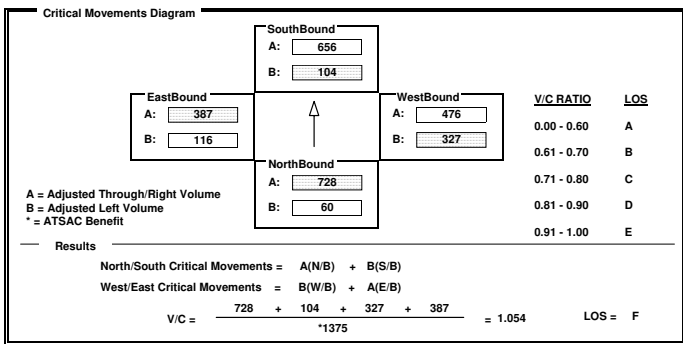

INTERSECTION DATA SUMMARY SHEET

N/S: W/E: I/S No:

AM/PM: Comments:

COUNT DATE: STUDY DATE: GROWTH FACTOR:

Volume/Lane/Signal Configurations

	NORTHBOUND			SOUTHBOUND			WESTBOUND			EASTBOUND		
	LT	TH	RT	LT	TH	RT	LT	TH	RT	LT	TH	RT
EXISTING	80	648	33	182	871	98	35	775	97	118	1181	75
AMBIENT												
RELATED												
PROJECT												
TOTAL	80	648	33	182	871	98	35	775	97	118	1181	75
LANE	1	1	1	1	2	1	1	2	1	1	2	1
SIGNAL	Phasing: Prot-Fix	RTOR: Auto		Phasing: Prot-Fix	RTOR: Auto		Phasing: Prot-Fix	RTOR: Auto		Phasing: Prot-Fix	RTOR: Auto	

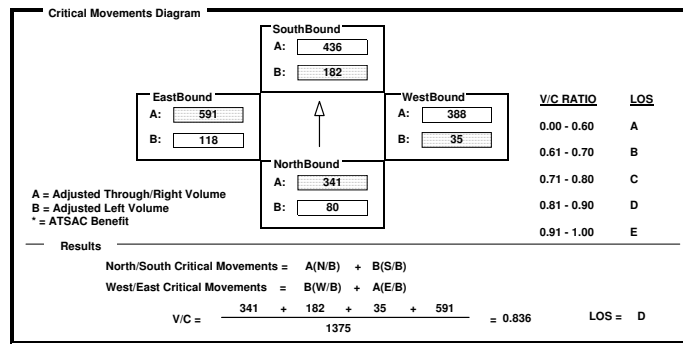

INTERSECTION DATA SUMMARY SHEET

N/S: W/E: I/S No:

AM/PM: Comments:

COUNT DATE: STUDY DATE: GROWTH FACTOR:

Volume/Lane/Signal Configurations

	NORTHBOUND			SOUTHBOUND			WESTBOUND			EASTBOUND		
	LT	TH	RT	LT	TH	RT	LT	TH	RT	LT	TH	RT
EXISTING	0	2576	1348	371	0	0	776	0	67	0	0	0
AMBIENT												
RELATED												
PROJECT												
TOTAL	0	2576	1348	371	0	0	776	0	67	0	0	0
LANE		2	1	1			2		1			
SIGNAL	Phasing: Prot-Fix	RTOR: Auto		Phasing: Prot-Fix	RTOR: Auto		Phasing: Split	RTOR: Free		Phasing:	RTOR:	

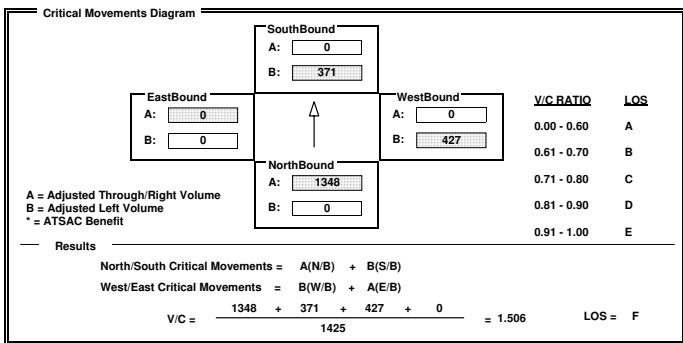

INTERSECTION DATA SUMMARY SHEET

N/S: W/E: I/S No:

AM/PM: Comments:

COUNT DATE: STUDY DATE: GROWTH FACTOR:

Volume/Lane/Signal Configurations

	NORTHBOUND			SOUTHBOUND			WESTBOUND			EASTBOUND		
	LT	TH	RT	LT	TH	RT	LT	TH	RT	LT	TH	RT
EXISTING	122	1223	133	108	1082	153	278	1364	170	219	1323	156
AMBIENT												
RELATED												
PROJECT												
TOTAL	122	1223	133	108	1082	153	278	1364	170	219	1323	156
LANE	1	2	1	1	2	1	2	2	1	2	2	1
SIGNAL	Phasing: Prot-Fix	RTOR: OLA		Phasing: Prot-Fix	RTOR: OLA		Phasing: Prot-Fix	RTOR: Auto		Phasing: Prot-Fix	RTOR: Auto	

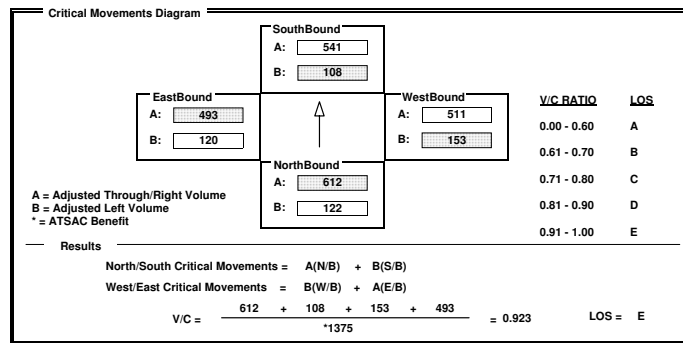

CalcaDB

April 2, 2009, Thursday 05:13:42 PM

INTERSECTION DATA SUMMARY SHEET

N/S: Lincoln Blvd W/E: Rose Ave I/S No: 160
 AM/PM: PM Comments: Existing
 COUNT DATE: STUDY DATE: GROWTH FACTOR:

Volume/Lane/Signal Configurations

	NORTHBOUND			SOUTHBOUND			WESTBOUND			EASTBOUND		
	LT	TH	RT	LT	TH	RT	LT	TH	RT	LT	TH	RT
EXISTING	120	1528	46	109	1462	188	67	262	81	174	450	173
AMBIENT												
RELATED												
PROJECT												
TOTAL	120	1528	46	109	1462	188	67	262	81	174	450	173

LANE: 1 2 1 | 1 2 1 | 1 1 1 | 1 1 1
 SIGNAL: Phasing RTOR Phasing RTOR Phasing RTOR Phasing RTOR
 [Perm Auto] [Perm Auto] [Perm Auto] [Perm Auto]

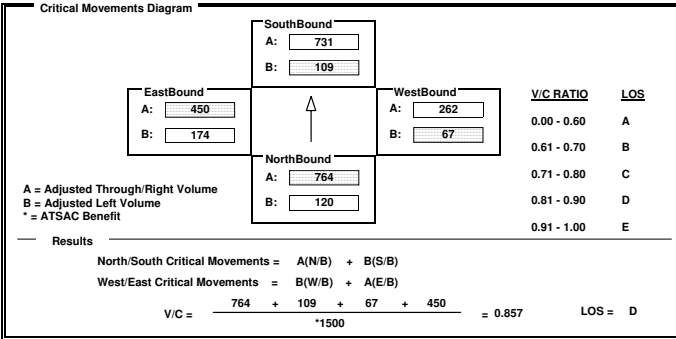

Developed by Chun Wong, 12/94

CalcaDB

April 2, 2009, Thursday 05:13:42 PM

INTERSECTION DATA SUMMARY SHEET

N/S: Western Ave W/E: Century Blvd I/S No: 161
 AM/PM: PM Comments: Existing
 COUNT DATE: STUDY DATE: GROWTH FACTOR:

Volume/Lane/Signal Configurations

	NORTHBOUND			SOUTHBOUND			WESTBOUND			EASTBOUND		
	LT	TH	RT	LT	TH	RT	LT	TH	RT	LT	TH	RT
EXISTING	108	852	168	131	798	163	136	961	160	174	1189	143
AMBIENT												
RELATED												
PROJECT												
TOTAL	108	852	168	131	798	163	136	961	160	174	1189	143

LANE: 1 2 1 | 1 1 1 | 1 2 1 | 1 2 1
 SIGNAL: Phasing RTOR Phasing RTOR Phasing RTOR Phasing RTOR
 [Prot-Fix OLA] [Prot-Fix Auto] [Prot-Fix Auto] [Prot-Fix Auto]

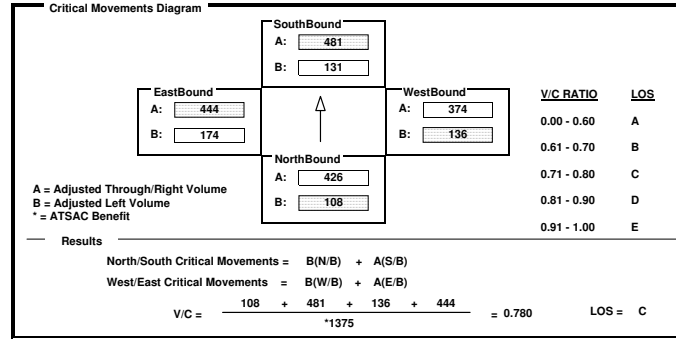

Developed by Chun Wong, 12/94

CalcaDB

April 2, 2009, Thursday 05:13:42 PM

INTERSECTION DATA SUMMARY SHEET

N/S: La Cienega Blvd W/E: Jefferson Blvd I/S No: 200
 AM/PM: PM Comments: Existing
 COUNT DATE: STUDY DATE: GROWTH FACTOR:

Volume/Lane/Signal Configurations

	NORTHBOUND			SOUTHBOUND			WESTBOUND			EASTBOUND		
	LT	TH	RT	LT	TH	RT	LT	TH	RT	LT	TH	RT
EXISTING	71	2337	292	65	2352	217	346	464	62	588	748	222
AMBIENT												
RELATED												
PROJECT												
TOTAL	71	2337	292	65	2352	217	346	464	62	588	748	222

LANE: 1 2 1 | 1 3 1 | 2 2 1 | 2 1 1
 SIGNAL: Phasing RTOR Phasing RTOR Phasing RTOR Phasing RTOR
 [Perm Auto] [Perm OLA] [Prot-Fix Auto] [Prot-Fix Auto]

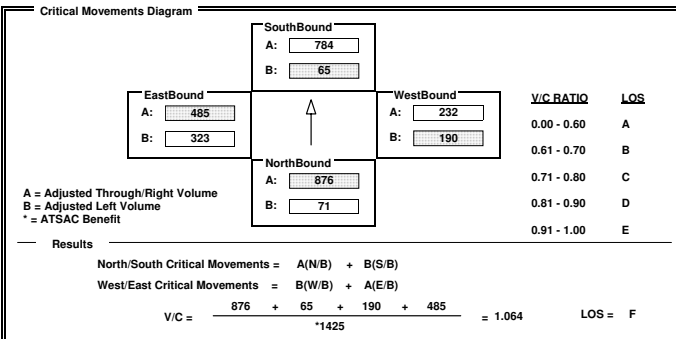

Developed by Chun Wong, 12/94

Project Title: Bradley West Project
Intersection: 12 - Arbor Vitae St and La Brea Ave
Description: Existing Conditions
Date/Time: AM PEAK HOUR

Thru Lane: 1600 vph N-S Split Phase: N
 Left Lane: 1600 vph E-W Split Phase: N
 Double Lt Penalty: 20 % Lost Time (% of cycle): 10
 ITS: 0 % V/C Round Off (decs.): 3
 OLA Movements: FF Movements:

APPROACH	MVMT	LANES	VOLUME	CAPACITY	V/C	ICU ANALYSIS
Southbound	RT	1.00	30	1,600	0.000	N-S(1): 0.180 N-S(2): 0.208 * E-W(1): 0.149 * E-W(2): 0.143 V/C: 0.357 Lost Time: 0.100 ITS: 0.000 ICU: 0.457 LOS: A
	TH	3.00	475	4,800	0.999 *	
	LT	1.00	45	1,600	0.028	
Westbound	RT	1.00	45	1,600	0.014	V/C: 0.357 Lost Time: 0.100 ITS: 0.000 ICU: 0.457 LOS: A
	TH	2.00	336	3,200	0.105	
	LT	1.00	44	1,600	0.028 *	
Northbound	RT	0.00	28	0	0.000	V/C: 0.357 Lost Time: 0.100 ITS: 0.000 ICU: 0.457 LOS: A
	TH	3.00	703	4,800	0.152	
	LT	1.00	175	1,600	0.109 *	
Eastbound	RT	1.00	128	1,600	0.025	V/C: 0.357 Lost Time: 0.100 ITS: 0.000 ICU: 0.457 LOS: A
	TH	1.00	194	1,600	0.121 *	
	LT	1.00	61	1,600	0.038	

Date/Time: MD PEAK HOUR

APPROACH	MVMT	LANES	VOLUME	CAPACITY	V/C	ICU ANALYSIS
Southbound	RT	1.00	42	1,600	0.002	N-S(1): 0.191 N-S(2): 0.239 * E-W(1): 0.174 * E-W(2): 0.108 V/C: 0.413 Lost Time: 0.100 ITS: 0.000 ICU: 0.513 LOS: A
	TH	3.00	639	4,800	0.133 *	
	LT	1.00	111	1,600	0.069	
Westbound	RT	1.00	63	1,600	0.005	V/C: 0.413 Lost Time: 0.100 ITS: 0.000 ICU: 0.513 LOS: A
	TH	2.00	199	3,200	0.059	
	LT	1.00	56	1,600	0.035 *	
Northbound	RT	0.00	62	0	0.000	V/C: 0.413 Lost Time: 0.100 ITS: 0.000 ICU: 0.513 LOS: A
	TH	3.00	525	4,800	0.122	
	LT	1.00	170	1,600	0.106 *	
Eastbound	RT	1.00	163	1,600	0.049	V/C: 0.413 Lost Time: 0.100 ITS: 0.000 ICU: 0.513 LOS: A
	TH	1.00	222	1,600	0.139 *	
	LT	1.00	78	1,600	0.049	

Date/Time: PM PEAK HOUR

APPROACH	MVMT	LANES	VOLUME	CAPACITY	V/C	ICU ANALYSIS
Southbound	RT	1.00	41	1,600	0.001	N-S(1): 0.204 N-S(2): 0.319 * E-W(1): 0.302 * E-W(2): 0.119 V/C: 0.621 Lost Time: 0.100 ITS: 0.000 ICU: 0.721 LOS: C
	TH	3.00	895	4,800	0.186 *	
	LT	1.00	90	1,600	0.056	
Westbound	RT	1.00	38	1,600	0.000	V/C: 0.621 Lost Time: 0.100 ITS: 0.000 ICU: 0.721 LOS: C
	TH	2.00	224	3,200	0.070	
	LT	1.00	54	1,600	0.034 *	
Northbound	RT	0.00	66	0	0.000	V/C: 0.621 Lost Time: 0.100 ITS: 0.000 ICU: 0.721 LOS: C
	TH	3.00	644	4,800	0.148	
	LT	1.00	212	1,600	0.133 *	
Eastbound	RT	1.00	207	1,600	0.063	V/C: 0.621 Lost Time: 0.100 ITS: 0.000 ICU: 0.721 LOS: C
	TH	1.00	428	1,600	0.268 *	
	LT	1.00	78	1,600	0.049	

* - Denotes critical movement

Project Title: Bradley West Project		Intersection: 50 - Duquesne Ave and Jefferson Blvd		Description: Existing Conditions			
Date/Time: AM PEAK HOUR		Thru Lane: 1600 vph		N-S Split Phase : N			
Left Lane: 1600 vph		E-W Split Phase : N		N-S(2): 0.019			
Double Lt Penalty: 20 %		Last Time (% of cycle): 10		E-W(1): 0.244			
ITS: 7 %		V/C Round Off (decs.): 3		E-W(2): 0.464 *			
OLA Movements : SBR		FF Movements:		V/C: 0.568			
				Lost Time: 0.100			
				ITS: -0.070			
				ICU: 0.598			
				LOS: A			
APPROACH	MVMT	LANES	VOLUME	CAPACITY	V/C	ICU ANALYSIS	
Southbound	RT	1.00	151	1,600	0.094	N-S(1): 0.104 *	
	TH	1.00	27	1,600	0.017		N-S(2): 0.019
	LT	1.00	162	1,600	0.101 *		E-W(1): 0.244
Westbound	RT	1.00	213	1,600	0.083	E-W(2): 0.464 *	
	TH	2.00	984	3,200	0.308 *		V/C: 0.568
	LT	1.00	9	1,600	0.006		Lost Time: 0.100
Northbound	RT	1.00	2	1,600	0.000	ITS: -0.070	
	TH	1.00	5	1,600	0.003 *		ICU: 0.598
	LT	1.00	3	1,600	0.002		LOS: A
Eastbound	RT	0.00	6	0	0.000		
	TH	2.00	757	3,200	0.238		
	LT	1.00	249	1,600	0.156 *		

* - Denotes critical movement

Project Title: Bradley West Project		Intersection: 55 - El Segundo Blvd and Sepulveda Blvd		Description: Existing Conditions			
Date/Time: AM PEAK HOUR		Thru Lane: 1600 vph		N-S Split Phase : N			
Left Lane: 1600 vph		E-W Split Phase : N		N-S(2): 0.237			
Double Lt Penalty: 20 %		Last Time (% of cycle): 10		E-W(1): 0.162			
ITS: 0 %		V/C Round Off (decs.): 3		E-W(2): 0.169 *			
OLA Movements :		FF Movements:		V/C: 0.719			
				Lost Time: 0.100			
				ITS: 0.000			
				ICU: 0.819			
				LOS: D			
APPROACH	MVMT	LANES	VOLUME	CAPACITY	V/C	ICU ANALYSIS	
Southbound	RT	1.00	127	1,600	0.043	N-S(1): 0.550 *	
	TH	4.00	935	6,400	0.146		N-S(2): 0.237
	LT	2.00	215	2,560	0.084 *		E-W(1): 0.162
Westbound	RT	1.00	213	1,600	0.091	E-W(2): 0.169 *	
	TH	2.00	305	3,200	0.095 *		V/C: 0.719
	LT	2.00	165	2,560	0.064		Lost Time: 0.100
Northbound	RT	0.00	284	0	0.000	ITS: 0.000	
	TH	4.00	2,701	6,400	0.466 *		ICU: 0.819
	LT	2.00	234	2,560	0.091		LOS: D
Eastbound	RT	1.00	187	1,600	0.071		
	TH	2.00	313	3,200	0.098		
	LT	1.00	118	1,600	0.074 *		

* - Denotes critical movement

Project Title: Bradley West Project		Intersection: 57 - Florence Ave and La Brea Ave		Description: Existing Conditions			
Date/Time: AM PEAK HOUR		Thru Lane: 1600 vph		N-S Split Phase : N			
Left Lane: 1600 vph		E-W Split Phase : N		N-S(2): 0.019			
Double Lt Penalty: 20 %		Last Time (% of cycle): 10		E-W(1): 0.202			
ITS: 0 %		V/C Round Off (decs.): 3		E-W(2): 0.349 *			
OLA Movements :		FF Movements:		V/C: 0.666			
				Lost Time: 0.100			
				ITS: 0.000			
				ICU: 0.766			
				LOS: C			
APPROACH	MVMT	LANES	VOLUME	CAPACITY	V/C	ICU ANALYSIS	
Southbound	RT	1.00	117	1,600	0.047	N-S(1): 0.317 *	
	TH	2.00	442	3,200	0.138		N-S(2): 0.019
	LT	1.00	71	1,600	0.044 *		E-W(1): 0.202
Westbound	RT	0.00	107	0	0.000	E-W(2): 0.349 *	
	TH	2.00	840	3,200	0.296 *		V/C: 0.666
	LT	1.00	134	1,600	0.064		Lost Time: 0.100
Northbound	RT	1.00	26	1,600	0.000	ITS: 0.000	
	TH	2.00	872	3,200	0.273 *		ICU: 0.766
	LT	1.00	29	1,600	0.018		LOS: C
Eastbound	RT	0.00	26	0	0.000		
	TH	2.00	350	3,200	0.118		
	LT	1.00	85	1,600	0.053 *		

* - Denotes critical movement

Project Title: Bradley West Project		Intersection: 58 - Florence Ave and La Cienega Blvd		Description: Existing Conditions			
Date/Time: AM PEAK HOUR		Thru Lane: 1600 vph		N-S Split Phase : Y			
Left Lane: 1600 vph		E-W Split Phase : N		N-S(2): 0.000			
Double Lt Penalty: 20 %		Last Time (% of cycle): 10		E-W(1): 0.277 *			
ITS: 0 %		V/C Round Off (decs.): 3		E-W(2): 0.250			
OLA Movements :		FF Movements:		V/C: 0.643			
				Lost Time: 0.100			
				ITS: 0.000			
				ICU: 0.743			
				LOS: C			
APPROACH	MVMT	LANES	VOLUME	CAPACITY	V/C	ICU ANALYSIS	
Southbound	RT	1.00	258	1,600	0.126	N-S(1): 0.351 *	
	TH	1.87	526	2,991	0.176		N-S(2): 0.000
	LT	1.13	318	1,447	0.220 *		E-W(1): 0.251
Westbound	RT	0.00	45	0	0.000	E-W(2): 0.342 *	
	TH	2.00	826	3,200	0.272 *		V/C: 0.643
	LT	1.00	214	1,600	0.134		Lost Time: 0.100
Northbound	RT	0.00	79	0	0.000	ITS: 0.000	
	TH	2.00	340	3,200	0.131 *		ICU: 0.743
	LT	1.00	36	1,600	0.023		LOS: C
Eastbound	RT	0.00	30	0	0.000		
	TH	2.00	345	3,200	0.117		
	LT	1.00	112	1,600	0.070 *		

* - Denotes critical movement

INTERSECTION DATA SUMMARY SHEET

N/S: W/E: I/S No:

AM/PM: Comments:

COUNT DATE: STUDY DATE: GROWTH FACTOR:

	NORTHBOUND			SOUTHBOUND			WESTBOUND			EASTBOUND		
	LT	TH	RT	LT	TH	RT	LT	TH	RT	LT	TH	RT
EXISTING	30	50	50	320	30	320	80	2640	470	420	1480	30
AMBIENT												
RELATED												
PROJECT												
TOTAL	30	50	50	320	30	320	80	2640	470	420	1480	30
LANE	1	2	1	2	1	1	1	4	1	2	4	1
SIGNAL	Phasing: Split	RTOR: Auto		Phasing: Split	RTOR: Auto		Phasing: Prot-Fix	RTOR: OLA		Phasing: Prot-Fix	RTOR: Auto	

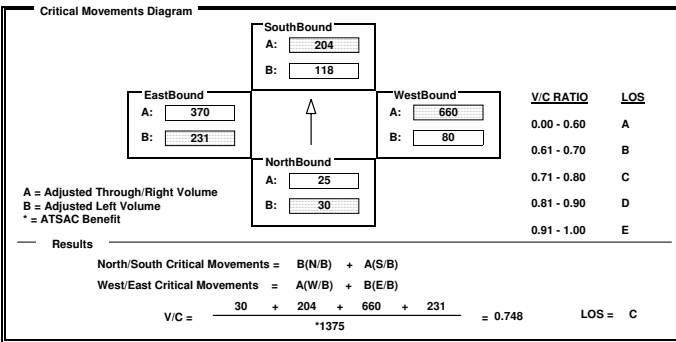

INTERSECTION DATA SUMMARY SHEET

N/S: W/E: I/S No:

AM/PM: Comments:

COUNT DATE: STUDY DATE: GROWTH FACTOR:

	NORTHBOUND			SOUTHBOUND			WESTBOUND			EASTBOUND		
	LT	TH	RT	LT	TH	RT	LT	TH	RT	LT	TH	RT
EXISTING	90	240	630	110	120	30	630	930	40	30	590	30
AMBIENT												
RELATED												
PROJECT												
TOTAL	90	240	630	110	120	30	630	930	40	30	590	30
LANE	1	2	1	1	1	1	2	1	1	1	2	1
SIGNAL	Phasing: Split	RTOR: OLA		Phasing: Split	RTOR: Auto		Phasing: Prot-Fix	RTOR: Auto		Phasing: Prot-Fix	RTOR: Auto	

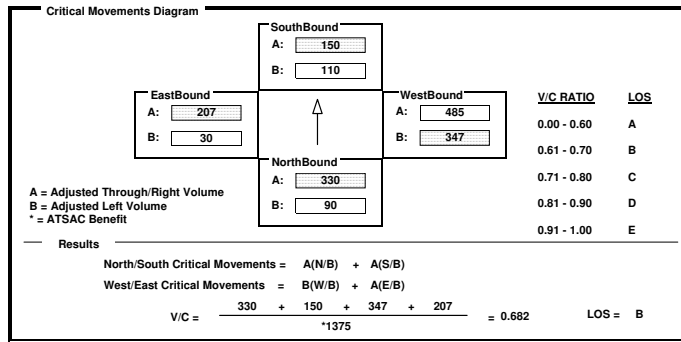

INTERSECTION DATA SUMMARY SHEET

N/S: W/E: I/S No:

AM/PM: Comments:

COUNT DATE: STUDY DATE: GROWTH FACTOR:

	NORTHBOUND			SOUTHBOUND			WESTBOUND			EASTBOUND		
	LT	TH	RT	LT	TH	RT	LT	TH	RT	LT	TH	RT
EXISTING	120	670	90	80	700	30	140	1220	210	30	610	90
AMBIENT												
RELATED												
PROJECT												
TOTAL	120	670	90	80	700	30	140	1220	210	30	610	90
LANE	1	2	1	1	1	1	1	2	1	1	2	1
SIGNAL	Phasing: Prot-Fix	RTOR: Auto		Phasing: Prot-Fix	RTOR: Auto		Phasing: Prot-Fix	RTOR: Auto		Phasing: Prot-Fix	RTOR: Auto	

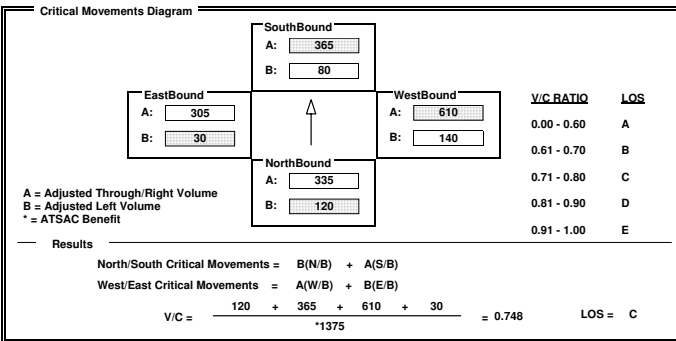

INTERSECTION DATA SUMMARY SHEET

N/S: W/E: I/S No:

AM/PM: Comments:

COUNT DATE: STUDY DATE: GROWTH FACTOR:

	NORTHBOUND			SOUTHBOUND			WESTBOUND			EASTBOUND		
	LT	TH	RT	LT	TH	RT	LT	TH	RT	LT	TH	RT
EXISTING	260	570	160	70	450	120	70	1010	100	110	240	160
AMBIENT												
RELATED												
PROJECT												
TOTAL	260	570	160	70	450	120	70	1010	100	110	240	160
LANE	1	2	1	1	1	1	1	1	1	1	1	1
SIGNAL	Phasing: Perm	RTOR: Auto		Phasing: Perm	RTOR: Auto		Phasing: Perm	RTOR: Auto		Phasing: Perm	RTOR: Auto	

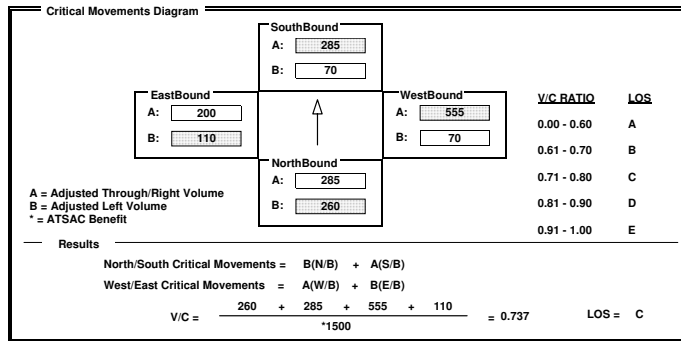

INTERSECTION DATA SUMMARY SHEET

N/S: W/E: I/S No:
 AM/PM: Comments:
 COUNT DATE: STUDY DATE: GROWTH FACTOR:

	NORTHBOUND			SOUTHBOUND			WESTBOUND			EASTBOUND		
	LT	TH	RT	LT	TH	RT	LT	TH	RT	LT	TH	RT
EXISTING	770	620	60	60	390	200	110	2220	150	210	1270	310
AMBIENT												
RELATED												
PROJECT												
TOTAL	770	620	60	60	390	200	110	2220	150	210	1270	310
LANE	2	1	1	2	2	1	1	3	1	1	3	1
SIGNAL	Prot-Fix	Auto		Prot-Fix	OLA		Prot-Fix	Auto		Prot-Fix	Auto	

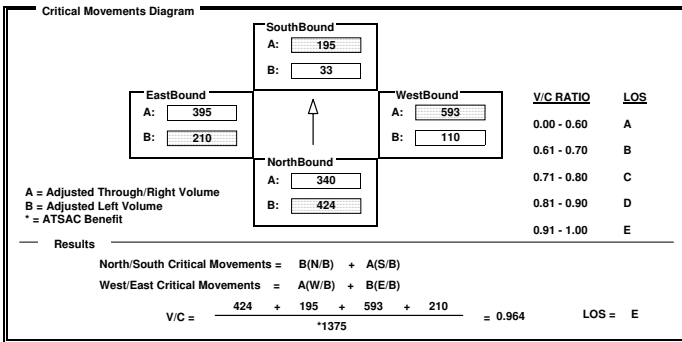

INTERSECTION DATA SUMMARY SHEET

N/S: W/E: I/S No:
 AM/PM: Comments:
 COUNT DATE: STUDY DATE: GROWTH FACTOR:

	NORTHBOUND			SOUTHBOUND			WESTBOUND			EASTBOUND		
	LT	TH	RT	LT	TH	RT	LT	TH	RT	LT	TH	RT
EXISTING	480	630	210	210	380	180	310	1200	790	190	530	100
AMBIENT												
RELATED												
PROJECT												
TOTAL	480	630	210	210	380	180	310	1200	790	190	530	100
LANE	2	2	1	2	2	1	2	3	1	2	2	1
SIGNAL	Prot-Fix	OLA		Prot-Fix	OLA		Prot-Fix	OLA		Prot-Fix	OLA	

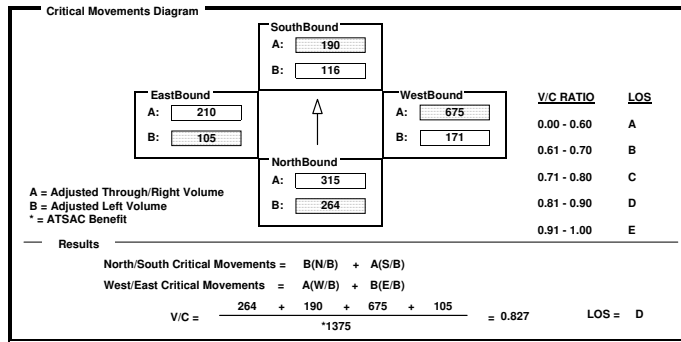

INTERSECTION DATA SUMMARY SHEET

N/S: W/E: I/S No:
 AM/PM: Comments:
 COUNT DATE: STUDY DATE: GROWTH FACTOR:

	NORTHBOUND			SOUTHBOUND			WESTBOUND			EASTBOUND		
	LT	TH	RT	LT	TH	RT	LT	TH	RT	LT	TH	RT
EXISTING	90	1490	30	40	990	200	10	10	20	250	10	320
AMBIENT												
RELATED												
PROJECT												
TOTAL	90	1490	30	40	990	200	10	10	20	250	10	320
LANE	1	2	1	1	2	1				1	1	1
SIGNAL	Prot-Fix	Auto		Prot-Fix	Auto		Prot-Fix	Auto		Prot-Fix	Auto	

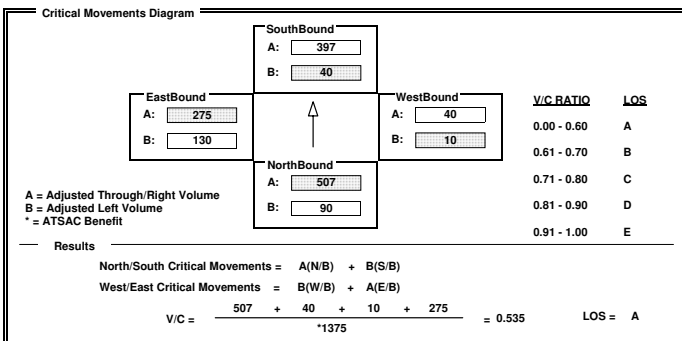

INTERSECTION DATA SUMMARY SHEET

N/S: W/E: I/S No:
 AM/PM: Comments:
 COUNT DATE: STUDY DATE: GROWTH FACTOR:

	NORTHBOUND			SOUTHBOUND			WESTBOUND			EASTBOUND		
	LT	TH	RT	LT	TH	RT	LT	TH	RT	LT	TH	RT
EXISTING	0	2120	350	300	1650	0	80	0	90	0	0	0
AMBIENT												
RELATED												
PROJECT												
TOTAL	0	2120	350	300	1650	0	80	0	90	0	0	0
LANE		4	1	2	4		1		1	1		
SIGNAL	Perm	Auto		Prot-Fix	Auto		Split	Auto		Split	Auto	

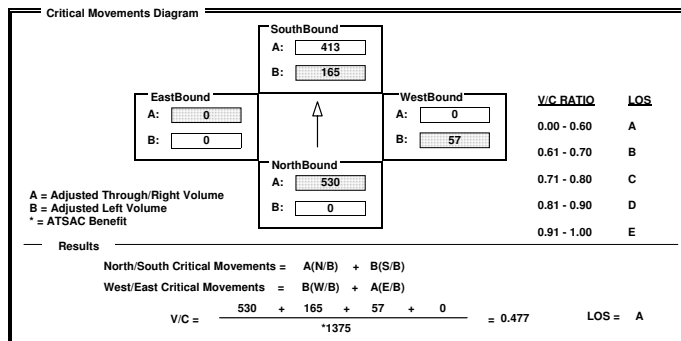

INTERSECTION DATA SUMMARY SHEET

N/S: W/E: I/S No:

AM/PM: Comments:

COUNT DATE: STUDY DATE: GROWTH FACTOR:

	NORTHBOUND			SOUTHBOUND			WESTBOUND			EASTBOUND		
	LT	TH	RT	LT	TH	RT	LT	TH	RT	LT	TH	RT
EXISTING	290	810	150	30	960	180	290	1190	10	120	410	60
AMBIENT												
RELATED												
PROJECT												
TOTAL	290	810	150	30	960	180	290	1190	10	120	410	60
LANE												
SIGNAL	Prot-Fix		Auto	Prot-Fix		Auto	Prot-Fix		Auto	Prot-Fix		Auto

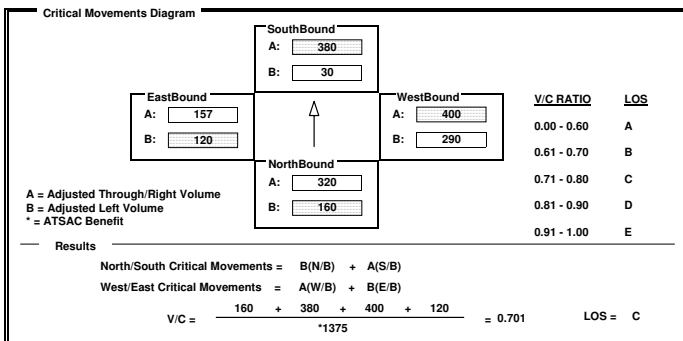

INTERSECTION DATA SUMMARY SHEET

N/S: W/E: I/S No:

AM/PM: Comments:

COUNT DATE: STUDY DATE: GROWTH FACTOR:

	NORTHBOUND			SOUTHBOUND			WESTBOUND			EASTBOUND		
	LT	TH	RT	LT	TH	RT	LT	TH	RT	LT	TH	RT
EXISTING	180	410	210	180	510	830	310	1390	660	100	810	530
AMBIENT												
RELATED												
PROJECT												
TOTAL	180	410	210	180	510	830	310	1390	660	100	810	530
LANE												
SIGNAL	Prot-Fix		OLA	Prot-Fix		OLA	Prot-Fix		Auto	Prot-Fix		OLA

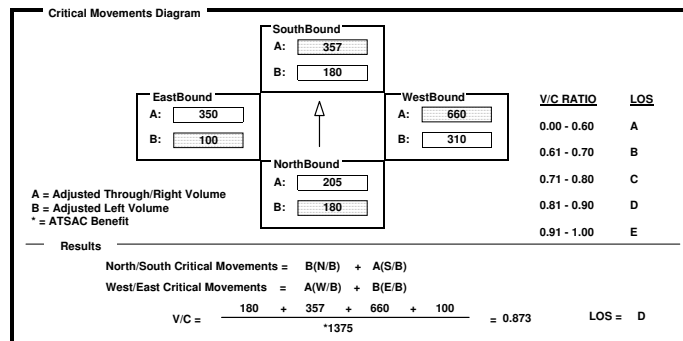

INTERSECTION DATA SUMMARY SHEET

N/S: W/E: I/S No:

AM/PM: Comments:

COUNT DATE: STUDY DATE: GROWTH FACTOR:

	NORTHBOUND			SOUTHBOUND			WESTBOUND			EASTBOUND		
	LT	TH	RT	LT	TH	RT	LT	TH	RT	LT	TH	RT
EXISTING	0	3240	30	0	1730	200	310	90	290	0	0	0
AMBIENT												
RELATED												
PROJECT												
TOTAL	0	3240	30	0	1730	200	310	90	290	0	0	0
LANE												
SIGNAL	Perm		Free	Perm		Auto	Split		Auto	<none>		Auto

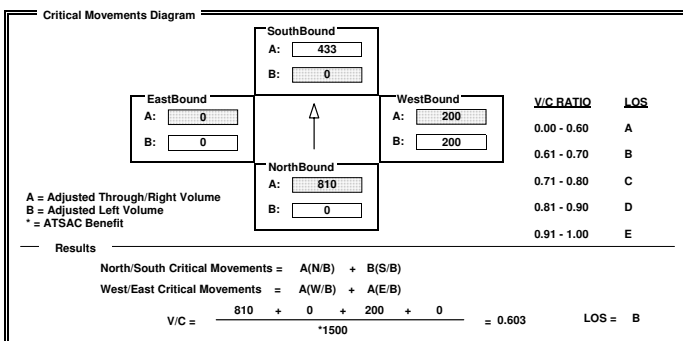

INTERSECTION DATA SUMMARY SHEET

N/S: W/E: I/S No:

AM/PM: Comments:

COUNT DATE: STUDY DATE: GROWTH FACTOR:

	NORTHBOUND			SOUTHBOUND			WESTBOUND			EASTBOUND		
	LT	TH	RT	LT	TH	RT	LT	TH	RT	LT	TH	RT
EXISTING	60	20	110	20	20	30	270	1310	90	30	700	110
AMBIENT												
RELATED												
PROJECT												
TOTAL	60	20	110	20	20	30	270	1310	90	30	700	110
LANE												
SIGNAL	Split		OLA	Split		Auto	Prot-Fix		Auto	Prot-Fix		Auto

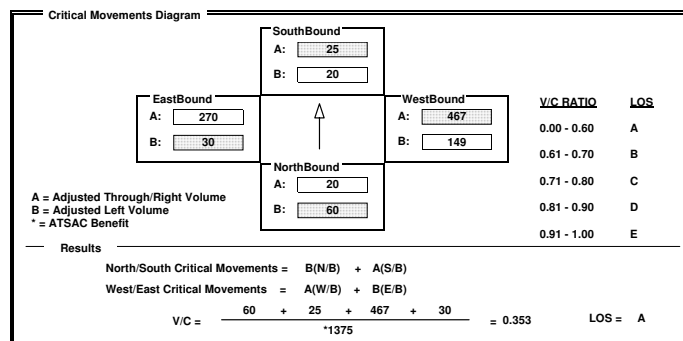

INTERSECTION DATA SUMMARY SHEET

N/S: W/E: I/S No:

AM/PM: Comments:

COUNT DATE: STUDY DATE: GROWTH FACTOR:

	NORTHBOUND			SOUTHBOUND			WESTBOUND			EASTBOUND		
	LT	TH	RT	LT	TH	RT	LT	TH	RT	LT	TH	RT
EXISTING	590	1860	50	70	1480	70	30	20	30	110	30	1020
AMBIENT												
RELATED												
PROJECT												
TOTAL	590	1860	50	70	1480	70	30	20	30	110	30	1020
LANE												
SIGNAL	Phasing		RTOR	Phasing		RTOR	Phasing		RTOR	Phasing		RTOR
	Prot-Fix		Auto	Prot-Fix		Auto	Perm		Auto	Perm		Free

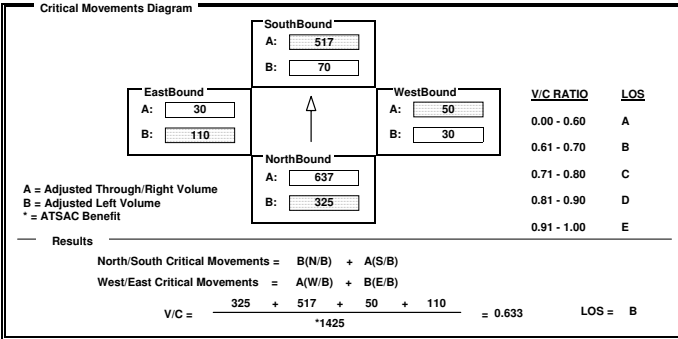

INTERSECTION DATA SUMMARY SHEET

N/S: W/E: I/S No:

AM/PM: Comments:

COUNT DATE: STUDY DATE: GROWTH FACTOR:

	NORTHBOUND			SOUTHBOUND			WESTBOUND			EASTBOUND		
	LT	TH	RT	LT	TH	RT	LT	TH	RT	LT	TH	RT
EXISTING	0	1920	1130	240	920	0	460	0	340	0	0	0
AMBIENT												
RELATED												
PROJECT												
TOTAL	0	1920	1130	240	920	0	460	0	340	0	0	0
LANE												
SIGNAL	Phasing		RTOR	Phasing		RTOR	Phasing		RTOR	Phasing		RTOR
	<none>		Free	Prot-Fix		Auto	Split		Auto	<none>		<none>

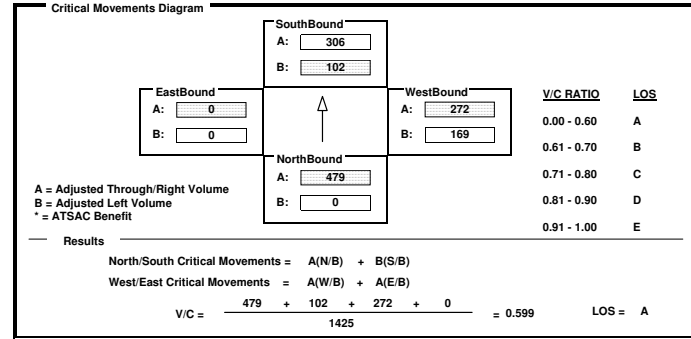

INTERSECTION DATA SUMMARY SHEET

N/S: W/E: I/S No:

AM/PM: Comments:

COUNT DATE: STUDY DATE: GROWTH FACTOR:

	NORTHBOUND			SOUTHBOUND			WESTBOUND			EASTBOUND		
	LT	TH	RT	LT	TH	RT	LT	TH	RT	LT	TH	RT
EXISTING	90	190	130	80	250	350	230	920	460	340	190	240
AMBIENT												
RELATED												
PROJECT												
TOTAL	90	190	130	80	250	350	230	920	460	340	190	240
LANE												
SIGNAL	Phasing		RTOR	Phasing		RTOR	Phasing		RTOR	Phasing		RTOR
	Prot-Fix		Auto	Prot-Fix		Auto	Prot-Fix		OLA	Prot-Fix		OLA

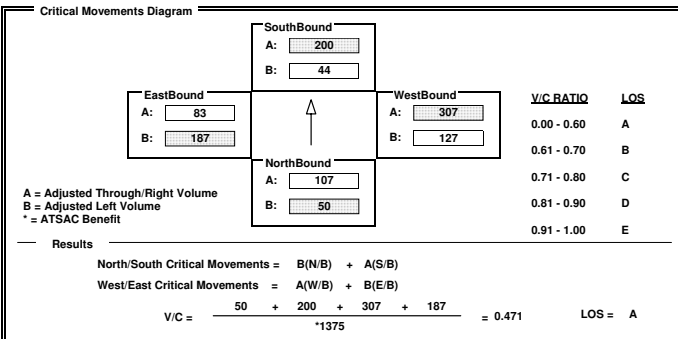

INTERSECTION DATA SUMMARY SHEET

N/S: W/E: I/S No:

AM/PM: Comments:

COUNT DATE: STUDY DATE: GROWTH FACTOR:

	NORTHBOUND			SOUTHBOUND			WESTBOUND			EASTBOUND		
	LT	TH	RT	LT	TH	RT	LT	TH	RT	LT	TH	RT
EXISTING	140	1670	720	280	2100	400	200	330	340	220	280	220
AMBIENT												
RELATED												
PROJECT												
TOTAL	140	1670	720	280	2100	400	200	330	340	220	280	220
LANE												
SIGNAL	Phasing		RTOR	Phasing		RTOR	Phasing		RTOR	Phasing		RTOR
	Prot-Fix		Auto	Prot-Fix		Auto	Prot-Fix		OLA	Prot-Fix		Auto

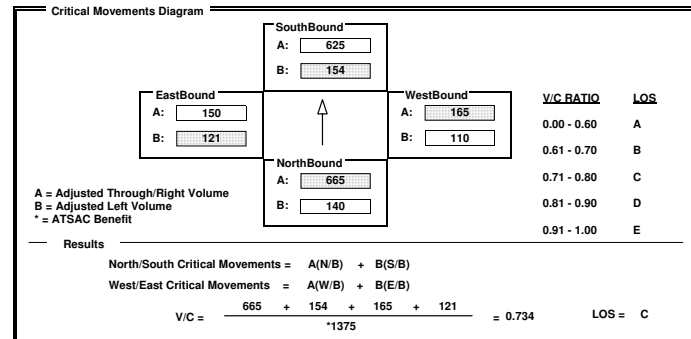

INTERSECTION DATA SUMMARY SHEET

N/S: 105 WB Off Ramps/Nash St W/E: Imperial Hwy I/S No: 73
 AM/PM: AM Comments: No Project
 COUNT DATE: STUDY DATE: GROWTH FACTOR:

	NORTHBOUND			SOUTHBOUND			WESTBOUND			EASTBOUND		
	LT	TH	RT	LT	TH	RT	LT	TH	RT	LT	TH	RT
EXISTING	20	0	30	400	1280	520	290	880	0	0	540	110
AMBIENT												
RELATED												
PROJECT												
TOTAL	20	0	30	400	1280	520	290	880	0	0	540	110
LANE	1	2	1	1	1	1	2	3	1	2	1	1
SIGNAL	Phasing: Split	RTOR: Auto	Phasing: Split	RTOR: Auto	Phasing: Prot-Fix	RTOR: Auto	Phasing: Prot-Fix	RTOR: Auto	Phasing: Perm	RTOR: Auto	Phasing: Perm	RTOR: Auto

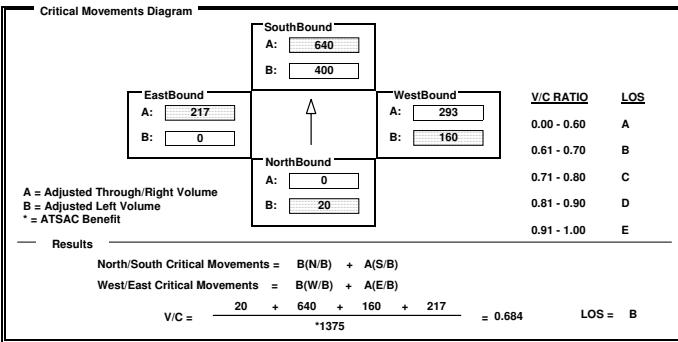

INTERSECTION DATA SUMMARY SHEET

N/S: 105 EB On Ramps W/E: Imperial Hwy I/S No: 74
 AM/PM: AM Comments: No Project
 COUNT DATE: STUDY DATE: GROWTH FACTOR:

	NORTHBOUND			SOUTHBOUND			WESTBOUND			EASTBOUND		
	LT	TH	RT	LT	TH	RT	LT	TH	RT	LT	TH	RT
EXISTING	1080	0	420	0	0	0	110	1220	0	0	350	640
AMBIENT												
RELATED												
PROJECT												
TOTAL	1080	0	420	0	0	0	110	1220	0	0	350	640
LANE	2	2	2	2	2	2	2	2	2	2	1	1
SIGNAL	Phasing: Split	RTOR: OLA	Phasing: <none>	RTOR: <none>	Phasing: Prot-Fix	RTOR: Auto	Phasing: Prot-Fix	RTOR: Auto	Phasing: Perm	RTOR: OLA	Phasing: Perm	RTOR: OLA

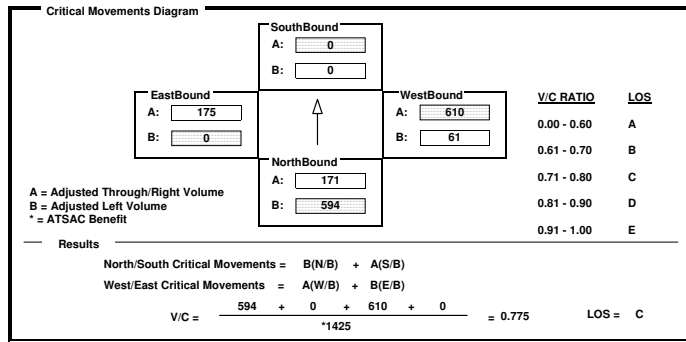

INTERSECTION DATA SUMMARY SHEET

N/S: Lincoln Blvd W/E: Jefferson Blvd I/S No: 78
 AM/PM: AM Comments: No Project
 COUNT DATE: STUDY DATE: GROWTH FACTOR:

	NORTHBOUND			SOUTHBOUND			WESTBOUND			EASTBOUND		
	LT	TH	RT	LT	TH	RT	LT	TH	RT	LT	TH	RT
EXISTING	20	1600	590	650	1670	210	260	110	490	260	320	20
AMBIENT												
RELATED												
PROJECT												
TOTAL	20	1600	590	650	1670	210	260	110	490	260	320	20
LANE	1	4	1	2	3	1	2	2	2	1	2	1
SIGNAL	Phasing: Prot-Fix	RTOR: OLA	Phasing: Prot-Fix	RTOR: OLA	Phasing: Prot-Fix	RTOR: OLA	Phasing: Prot-Fix	RTOR: OLA	Phasing: Prot-Fix	RTOR: Auto	Phasing: Prot-Fix	RTOR: Auto

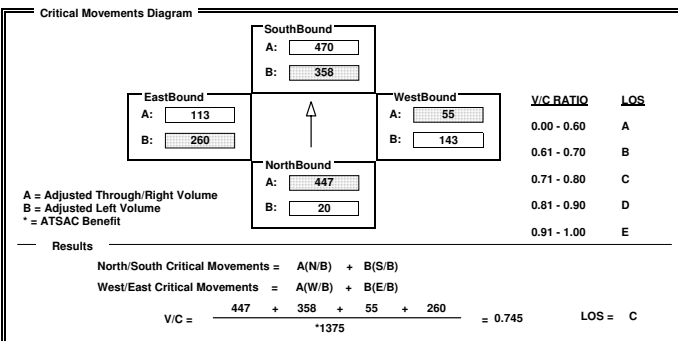

INTERSECTION DATA SUMMARY SHEET

N/S: La Cienega Blvd W/E: La Tijera Blvd I/S No: 88
 AM/PM: AM Comments: No Project
 COUNT DATE: STUDY DATE: GROWTH FACTOR:

	NORTHBOUND			SOUTHBOUND			WESTBOUND			EASTBOUND		
	LT	TH	RT	LT	TH	RT	LT	TH	RT	LT	TH	RT
EXISTING	0	2670	120	0	2340	1130	0	0	0	750	190	10
AMBIENT												
RELATED												
PROJECT												
TOTAL	0	2670	120	0	2340	1130	0	0	0	750	190	10
LANE	2	1	1	3	1	1	3	1	1	3	1	1
SIGNAL	Phasing: Perm	RTOR: Auto	Phasing: Perm	RTOR: OLA	Phasing: <none>	RTOR: <none>	Phasing: Split	RTOR: Auto	Phasing: Split	RTOR: Auto	Phasing: Split	RTOR: Auto

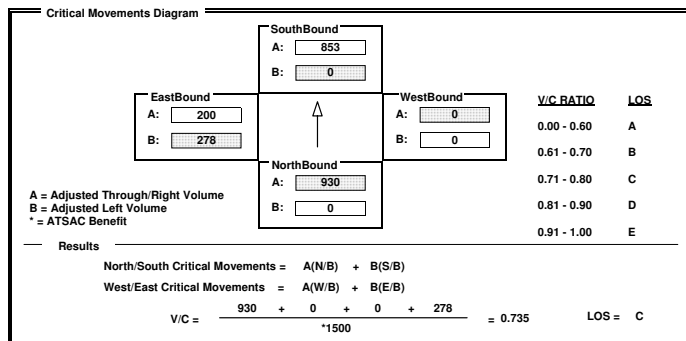

INTERSECTION DATA SUMMARY SHEET

N/S: Lincoln Blvd W/E: La Tijera Blvd I/S No: 99
 AM/PM: AM Comments: No Project
 COUNT DATE: STUDY DATE: GROWTH FACTOR:

	NORTHBOUND			SOUTHBOUND			WESTBOUND			EASTBOUND		
	LT	TH	RT	LT	TH	RT	LT	TH	RT	LT	TH	RT
EXISTING	50	1430	20	20	1240	30	10	10	20	40	20	40
AMBIENT												
RELATED												
PROJECT												
TOTAL	50	1430	20	20	1240	30	10	10	20	40	20	40
LANE	2	2	1	1	2	1	1	1	1	1	1	1
Phasing	Prot-Fix		Auto	Prot-Fix		Auto	Perm		Auto	Perm		OLA
SIGNAL	Prot-Fix		Auto	Prot-Fix		Auto	Perm		Auto	Perm		OLA

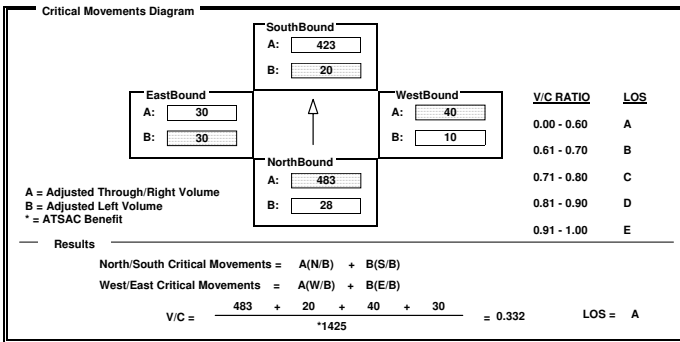

INTERSECTION DATA SUMMARY SHEET

N/S: La Tijera W/E: Manchester Ave I/S No: 100
 AM/PM: AM Comments: No Project
 COUNT DATE: STUDY DATE: GROWTH FACTOR:

	NORTHBOUND			SOUTHBOUND			WESTBOUND			EASTBOUND		
	LT	TH	RT	LT	TH	RT	LT	TH	RT	LT	TH	RT
EXISTING	20	420	130	20	680	280	110	1170	30	160	540	20
AMBIENT												
RELATED												
PROJECT												
TOTAL	20	420	130	20	680	280	110	1170	30	160	540	20
LANE	1	2	1	1	2	1	1	2	1	1	2	1
Phasing	Prot-Fix		Auto	Prot-Fix		Auto	Prot-Fix		Auto	Prot-Fix		Free
SIGNAL	Prot-Fix		Auto	Prot-Fix		Auto	Prot-Fix		Auto	Prot-Fix		Free

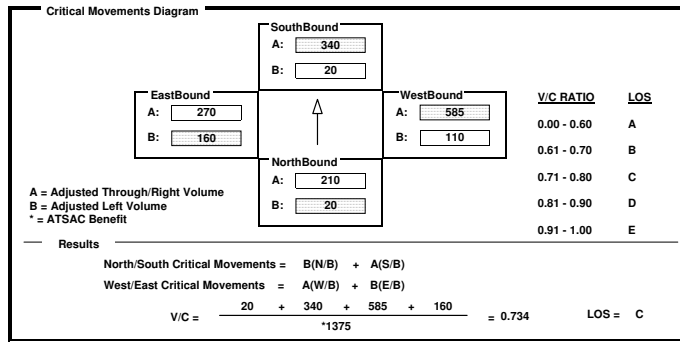

INTERSECTION DATA SUMMARY SHEET

N/S: Sepulveda Blvd W/E: La Tijera Blvd I/S No: 101
 AM/PM: AM Comments: No Project
 COUNT DATE: STUDY DATE: GROWTH FACTOR:

	NORTHBOUND			SOUTHBOUND			WESTBOUND			EASTBOUND		
	LT	TH	RT	LT	TH	RT	LT	TH	RT	LT	TH	RT
EXISTING	110	1390	150	70	1090	60	480	200	40	50	320	80
AMBIENT												
RELATED												
PROJECT												
TOTAL	110	1390	150	70	1090	60	480	200	40	50	320	80
LANE	1	3	1	1	3	1	1	2	1	1	2	1
Phasing	Prot-Fix		OLA	Prot-Fix		OLA	Perm		Auto	Prot-Fix		OLA
SIGNAL	Prot-Fix		OLA	Prot-Fix		OLA	Perm		Auto	Prot-Fix		OLA

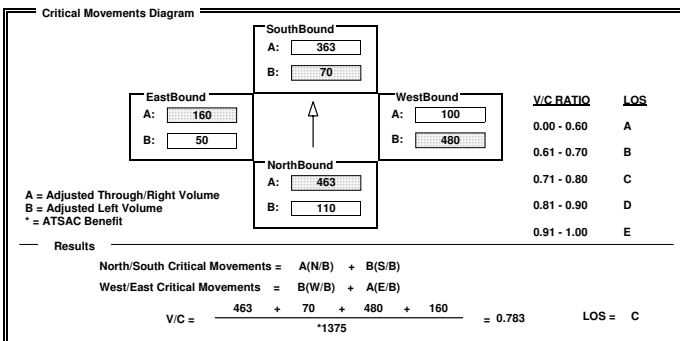

INTERSECTION DATA SUMMARY SHEET

N/S: 405 NB Ramps W/E: La Tijera Blvd I/S No: 102
 AM/PM: AM Comments: No Project
 COUNT DATE: STUDY DATE: GROWTH FACTOR:

	NORTHBOUND			SOUTHBOUND			WESTBOUND			EASTBOUND		
	LT	TH	RT	LT	TH	RT	LT	TH	RT	LT	TH	RT
EXISTING	230	0	180	0	0	0	0	1180	410	470	770	0
AMBIENT												
RELATED												
PROJECT												
TOTAL	230	0	180	0	0	0	0	1180	410	470	770	0
LANE	1		1					5	1	2	3	
Phasing	Split		Auto	<none>		<none>	Perm		Auto	Prot-Fix		<none>
SIGNAL	Split		Auto	<none>		<none>	Perm		Auto	Prot-Fix		<none>

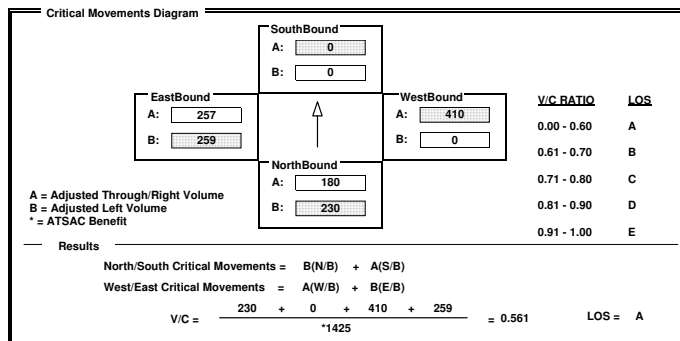

INTERSECTION DATA SUMMARY SHEET

N/S: La Tijera Blvd W/E: 405 SB Ramps I/S No: 103
AM/PM: AM Comments: No Project
COUNT DATE: STUDY DATE: GROWTH FACTOR:

Volume/Lane/Signal Configurations table with columns for Northbound, Southbound, Westbound, Eastbound and rows for Existing, Ambient, Related, Project, Total, Lane, and Signal.

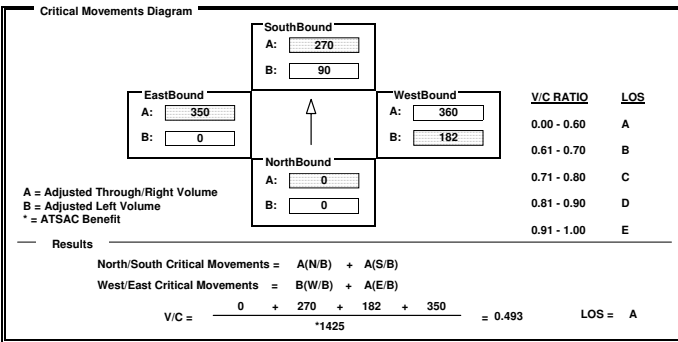

INTERSECTION DATA SUMMARY SHEET

N/S: Lincoln Blvd W/E: LMU Dr I/S No: 104
AM/PM: AM Comments: No Project
COUNT DATE: STUDY DATE: GROWTH FACTOR:

Volume/Lane/Signal Configurations table with columns for Northbound, Southbound, Westbound, Eastbound and rows for Existing, Ambient, Related, Project, Total, Lane, and Signal.

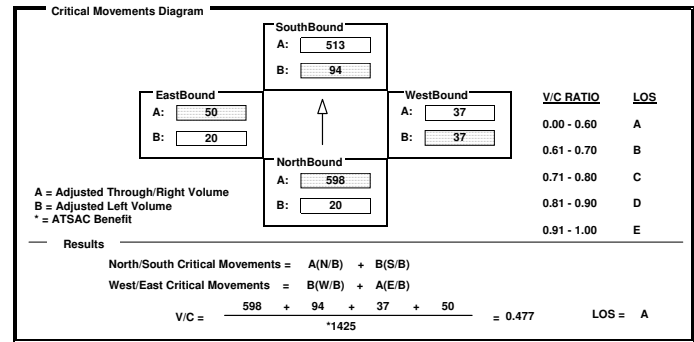

INTERSECTION DATA SUMMARY SHEET

N/S: Lincoln Blvd W/E: Manchester Blvd I/S No: 105
AM/PM: AM Comments: No Project
COUNT DATE: STUDY DATE: GROWTH FACTOR:

Volume/Lane/Signal Configurations table with columns for Northbound, Southbound, Westbound, Eastbound and rows for Existing, Ambient, Related, Project, Total, Lane, and Signal.

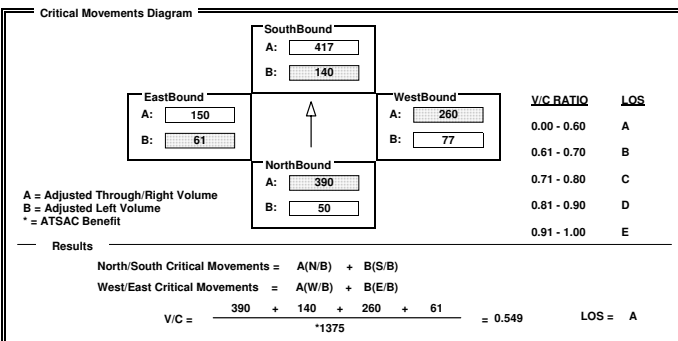

INTERSECTION DATA SUMMARY SHEET

N/S: Lincoln Blvd W/E: Marina Pointe Dr/ Maxella Ave I/S No: 106
AM/PM: AM Comments: No Project
COUNT DATE: STUDY DATE: GROWTH FACTOR:

Volume/Lane/Signal Configurations table with columns for Northbound, Southbound, Westbound, Eastbound and rows for Existing, Ambient, Related, Project, Total, Lane, and Signal.

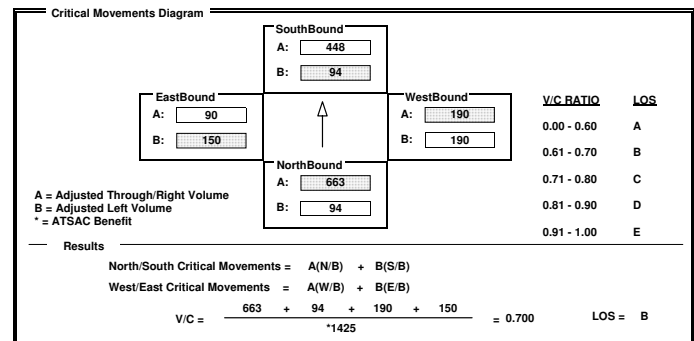

INTERSECTION DATA SUMMARY SHEET

N/S: Lincoln Blvd W/E: Mindanao Way I/S No: 107
 AM/PM: AM Comments: No Project
 COUNT DATE: STUDY DATE: GROWTH FACTOR:

	NORTHBOUND			SOUTHBOUND			WESTBOUND			EASTBOUND		
	LT	TH	RT	LT	TH	RT	LT	TH	RT	LT	TH	RT
EXISTING	120	1430	250	220	1190	50	250	660	120	10	440	140
AMBIENT												
RELATED												
PROJECT												
TOTAL	120	1430	250	220	1190	50	250	660	120	10	440	140
LANE	1	3	1	1	2	1	2	1	1	1	1	1
SIGNAL	Prot-Fix	OLA	Prot-Fix	Auto	Prot-Fix	<none>	Prot-Fix	<none>	Perm	Auto		

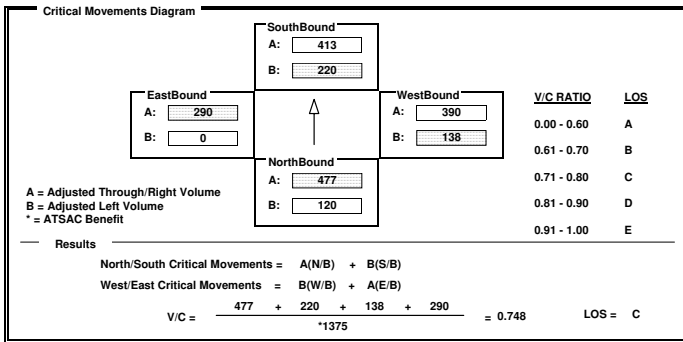

INTERSECTION DATA SUMMARY SHEET

N/S: Sepulveda Blvd W/E: Lincoln Blvd I/S No: 108
 AM/PM: AM Comments: No Project
 COUNT DATE: STUDY DATE: GROWTH FACTOR:

	NORTHBOUND			SOUTHBOUND			WESTBOUND			EASTBOUND		
	LT	TH	RT	LT	TH	RT	LT	TH	RT	LT	TH	RT
EXISTING	1360	1820	390	0	1500	10	0	0	10	0	0	1210
AMBIENT												
RELATED												
PROJECT												
TOTAL	1360	1820	390	0	1500	10	0	0	10	0	0	1210
LANE	4	2	1	3	1				1			4
SIGNAL	Prot-Fix	Auto	<none>	Auto	<none>	Auto	<none>	Auto	<none>	Auto	<none>	Auto

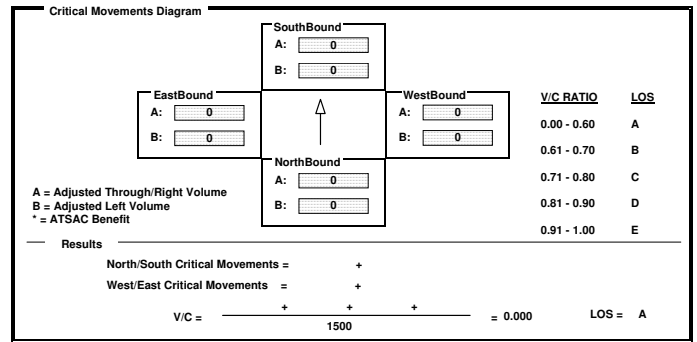

INTERSECTION DATA SUMMARY SHEET

N/S: Lincoln Blvd W/E: Venice Blvd I/S No: 109
 AM/PM: AM Comments: No Project
 COUNT DATE: STUDY DATE: GROWTH FACTOR:

	NORTHBOUND			SOUTHBOUND			WESTBOUND			EASTBOUND		
	LT	TH	RT	LT	TH	RT	LT	TH	RT	LT	TH	RT
EXISTING	220	1680	160	190	1270	40	270	570	280	120	810	260
AMBIENT												
RELATED												
PROJECT												
TOTAL	220	1680	160	190	1270	40	270	570	280	120	810	260
LANE	2	2	1	2	2	1	2	2	1	2	3	1
SIGNAL	Prot-Fix	Auto	Prot-Fix	Auto	Prot-Fix	OLA	Prot-Fix	OLA				

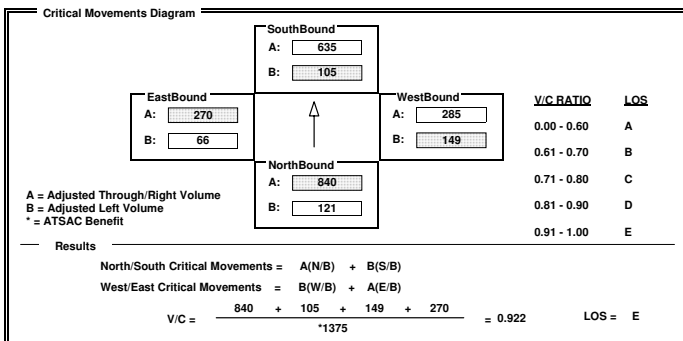

INTERSECTION DATA SUMMARY SHEET

N/S: Lincoln Blvd W/E: Washington Blvd I/S No: 110
 AM/PM: AM Comments: No Project
 COUNT DATE: STUDY DATE: GROWTH FACTOR:

	NORTHBOUND			SOUTHBOUND			WESTBOUND			EASTBOUND		
	LT	TH	RT	LT	TH	RT	LT	TH	RT	LT	TH	RT
EXISTING	380	1750	270	230	1540	180	160	690	230	140	720	500
AMBIENT												
RELATED												
PROJECT												
TOTAL	380	1750	270	230	1540	180	160	690	230	140	720	500
LANE	2	2	1	2	2	1	2	2	1	2	2	1
SIGNAL	Prot-Fix	Auto	Prot-Fix	Auto	Prot-Fix	OLA	Prot-Fix	OLA				

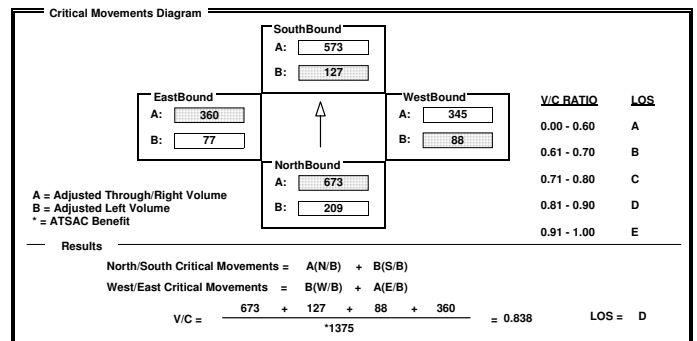

INTERSECTION DATA SUMMARY SHEET

N/S: W/E: I/S No:

AM/PM: Comments:

COUNT DATE: STUDY DATE: GROWTH FACTOR:

Volume/Lane/Signal Configurations

	NORTHBOUND			SOUTHBOUND			WESTBOUND			EASTBOUND		
	LT	TH	RT	LT	TH	RT	LT	TH	RT	LT	TH	RT
EXISTING	10	2050	10	110	1200	70	30	30	250	40	70	360
AMBIENT												
RELATED												
PROJECT												
TOTAL	10	2050	10	110	1200	70	30	30	250	40	70	360
LANE	1	3	1	1	2	1	1	1	1	2	1	1
Phasing	Prot-Fix		OLA		Prot-Fix		OLA		Prot-Fix		OLA	
RTOR	Auto		Auto		Auto		Auto		Auto		Auto	
SIGNAL	Prot-Fix		Auto		Prot-Fix		Auto		Prot-Fix		Auto	

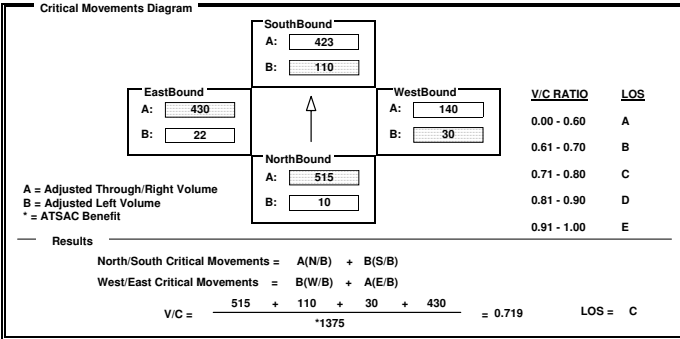

INTERSECTION DATA SUMMARY SHEET

N/S: W/E: I/S No:

AM/PM: Comments:

COUNT DATE: STUDY DATE: GROWTH FACTOR:

Volume/Lane/Signal Configurations

	NORTHBOUND			SOUTHBOUND			WESTBOUND			EASTBOUND		
	LT	TH	RT	LT	TH	RT	LT	TH	RT	LT	TH	RT
EXISTING	110	1430	50	150	970	120	90	930	390	140	520	90
AMBIENT												
RELATED												
PROJECT												
TOTAL	110	1430	50	150	970	120	90	930	390	140	520	90
LANE	1	3	1	1	3	1	1	2	1	2	2	1
Phasing	Prot-Fix		Auto		Prot-Fix		Auto		Prot-Fix		Auto	
RTOR	Auto		Auto		Auto		Auto		Auto		Auto	
SIGNAL	Prot-Fix		Auto		Prot-Fix		Auto		Prot-Fix		Auto	

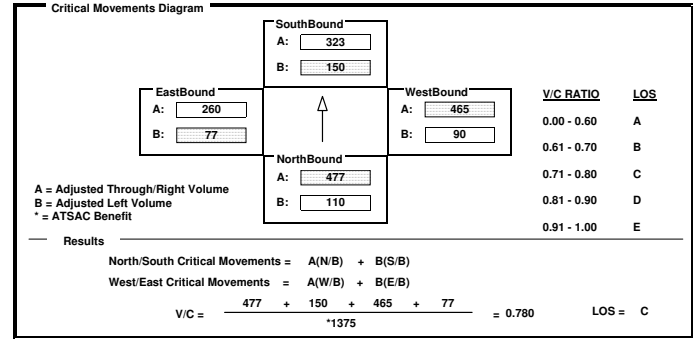

INTERSECTION DATA SUMMARY SHEET

N/S: W/E: I/S No:

AM/PM: Comments:

COUNT DATE: STUDY DATE: GROWTH FACTOR:

Volume/Lane/Signal Configurations

	NORTHBOUND			SOUTHBOUND			WESTBOUND			EASTBOUND		
	LT	TH	RT	LT	TH	RT	LT	TH	RT	LT	TH	RT
EXISTING	180	1600	50	140	1280	50	140	480	100	20	190	80
AMBIENT												
RELATED												
PROJECT												
TOTAL	180	1600	50	140	1280	50	140	480	100	20	190	80
LANE	1	3	1	1	3	1	1	1	1	1	2	1
Phasing	Prot-Fix		OLA		Prot-Fix		OLA		Prot-Fix		Auto	
RTOR	Auto		Auto		Auto		Auto		Auto		Auto	
SIGNAL	Prot-Fix		Auto		Prot-Fix		Auto		Prot-Fix		Auto	

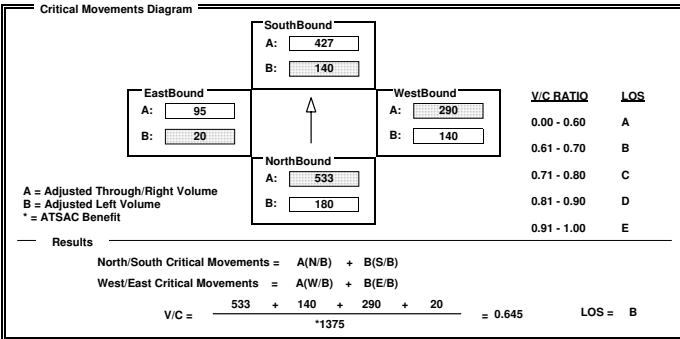

INTERSECTION DATA SUMMARY SHEET

N/S: W/E: I/S No:

AM/PM: Comments:

COUNT DATE: STUDY DATE: GROWTH FACTOR:

Volume/Lane/Signal Configurations

	NORTHBOUND			SOUTHBOUND			WESTBOUND			EASTBOUND		
	LT	TH	RT	LT	TH	RT	LT	TH	RT	LT	TH	RT
EXISTING	50	1960	20	100	1210	210	30	140	250	600	50	60
AMBIENT												
RELATED												
PROJECT												
TOTAL	50	1960	20	100	1210	210	30	140	250	600	50	60
LANE	1	3	1	1	2	1	1	1	1	2	1	1
Phasing	Prot-Fix		Auto		Prot-Fix		Auto		Split		Auto	
RTOR	Auto		Auto		Auto		Auto		Auto		Auto	
SIGNAL	Prot-Fix		Auto		Prot-Fix		Auto		Split		Auto	

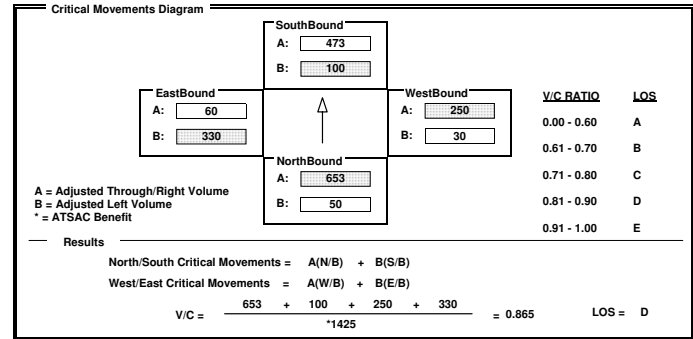

INTERSECTION DATA SUMMARY SHEET

N/S: W/E: I/S No:

AM/PM: Comments:

COUNT DATE: STUDY DATE: GROWTH FACTOR:

Volume/Lane/Signal Configurations

	NORTHBOUND			SOUTHBOUND			WESTBOUND			EASTBOUND		
	LT	TH	RT	LT	TH	RT	LT	TH	RT	LT	TH	RT
EXISTING	100	1890	20	50	1000	130	30	180	110	140	90	80
AMBIENT												
RELATED												
PROJECT												
TOTAL	100	1890	20	50	1000	130	30	180	110	140	90	80
LANE	1 2 1			1 3 1			1 1 1			1 1 1		
SIGNAL	Phasing		RTOR	Phasing		RTOR	Phasing		RTOR	Phasing		RTOR
	Perm		Auto	Perm		Auto	Perm		Auto	Perm		Auto

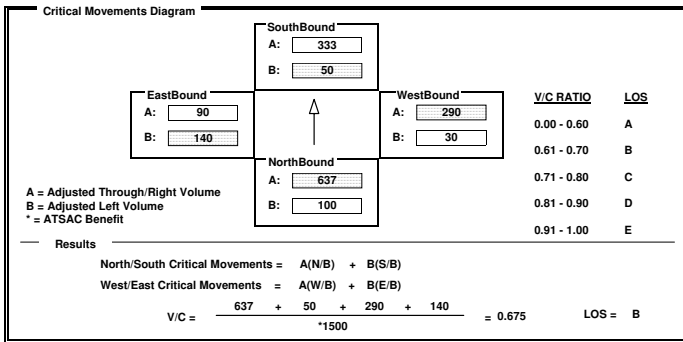

INTERSECTION DATA SUMMARY SHEET

N/S: W/E: I/S No:

AM/PM: Comments:

COUNT DATE: STUDY DATE: GROWTH FACTOR:

Volume/Lane/Signal Configurations

	NORTHBOUND			SOUTHBOUND			WESTBOUND			EASTBOUND		
	LT	TH	RT	LT	TH	RT	LT	TH	RT	LT	TH	RT
EXISTING	50	1820	10	30	1080	50	10	100	40	70	90	50
AMBIENT												
RELATED												
PROJECT												
TOTAL	50	1820	10	30	1080	50	10	100	40	70	90	50
LANE	1 2 1			1 2 1			1 1 1			1 1 1		
SIGNAL	Phasing		RTOR	Phasing		RTOR	Phasing		RTOR	Phasing		RTOR
	Perm		Auto	Perm		Auto	Perm		Auto	Perm		Auto

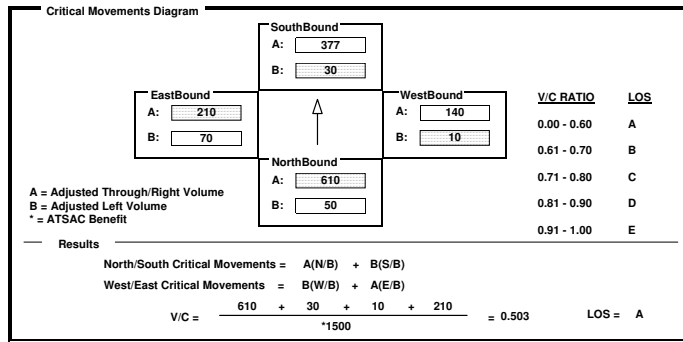

INTERSECTION DATA SUMMARY SHEET

N/S: W/E: I/S No:

AM/PM: Comments:

COUNT DATE: STUDY DATE: GROWTH FACTOR:

Volume/Lane/Signal Configurations

	NORTHBOUND			SOUTHBOUND			WESTBOUND			EASTBOUND		
	LT	TH	RT	LT	TH	RT	LT	TH	RT	LT	TH	RT
EXISTING	0	2230	0	0	0	0	0	0	2090	0	0	0
AMBIENT												
RELATED												
PROJECT												
TOTAL	0	2230	0	0	0	0	0	0	2090	0	0	0
LANE	3			0			3			0		
SIGNAL	Phasing		RTOR	Phasing		RTOR	Phasing		RTOR	Phasing		RTOR
	Split		<none>	<none>		<none>	Split		<none>	<none>		<none>

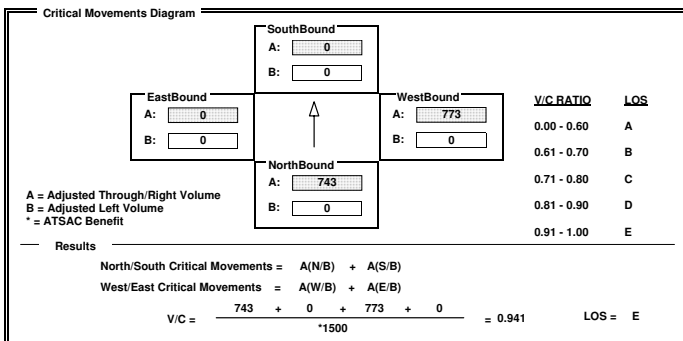

INTERSECTION DATA SUMMARY SHEET

N/S: W/E: I/S No:

AM/PM: Comments:

COUNT DATE: STUDY DATE: GROWTH FACTOR:

Volume/Lane/Signal Configurations

	NORTHBOUND			SOUTHBOUND			WESTBOUND			EASTBOUND		
	LT	TH	RT	LT	TH	RT	LT	TH	RT	LT	TH	RT
EXISTING	180	730	40	110	820	310	30	40	100	220	60	70
AMBIENT												
RELATED												
PROJECT												
TOTAL	180	730	40	110	820	310	30	40	100	220	60	70
LANE	1 2 1			1 3 1			1 1 1			2 1 1		
SIGNAL	Phasing		RTOR	Phasing		RTOR	Phasing		RTOR	Phasing		RTOR
	Prot-Fix		Auto	Perm		Free	Perm		Auto	Prot-Fix		Auto

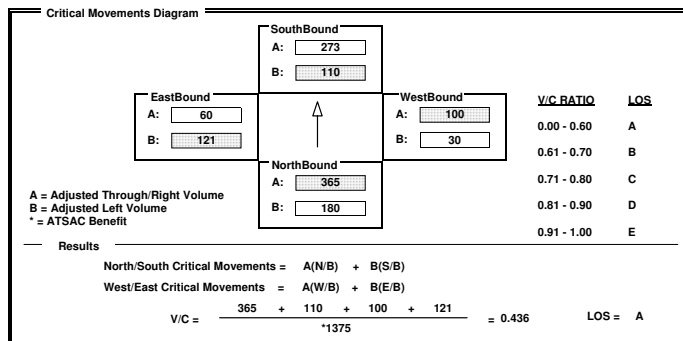

INTERSECTION DATA SUMMARY SHEET

N/S: Airport Blvd W/E: 98 St I/S No: 144
AM/PM: AM Comments: No Project
COUNT DATE: STUDY DATE: GROWTH FACTOR:

Volume/Lane/Signal Configurations table with columns for Northbound, Southbound, Westbound, Eastbound and rows for Existing, Ambient, Related, Project, Total, Lane, and Signal.

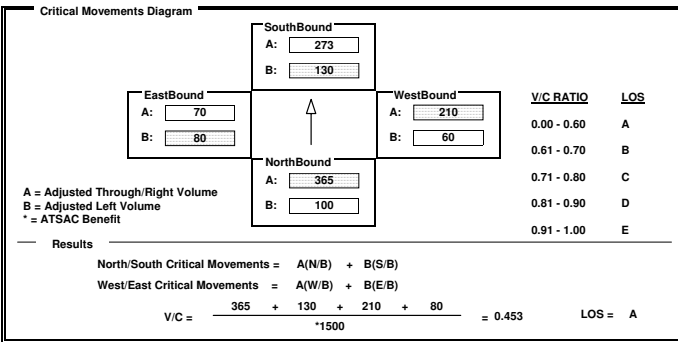

INTERSECTION DATA SUMMARY SHEET

N/S: Sepulveda Eastway W/E: Westchester Pkwy I/S No: 146
AM/PM: AM Comments: No Project
COUNT DATE: STUDY DATE: GROWTH FACTOR:

Volume/Lane/Signal Configurations table with columns for Northbound, Southbound, Westbound, Eastbound and rows for Existing, Ambient, Related, Project, Total, Lane, and Signal.

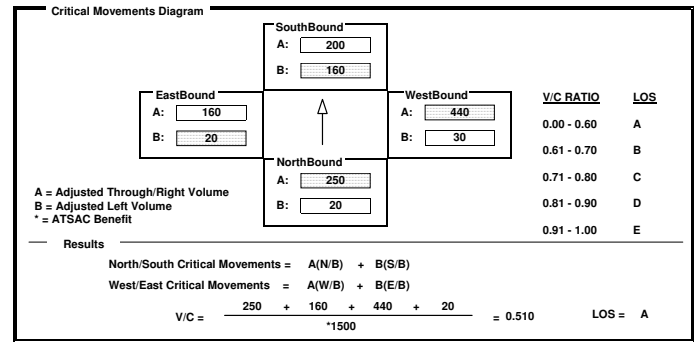

INTERSECTION DATA SUMMARY SHEET

N/S: La Cienega Blvd W/E: I-405 SB Ramps N/O Century I/S No: 96
AM/PM: AM Comments: Cumulative Adjusted (2013) No Project
COUNT DATE: STUDY DATE: GROWTH FACTOR:

Volume/Lane/Signal Configurations table with columns for Northbound, Southbound, Westbound, Eastbound and rows for Existing, Ambient, Related, Project, Total, Lane, and Signal.

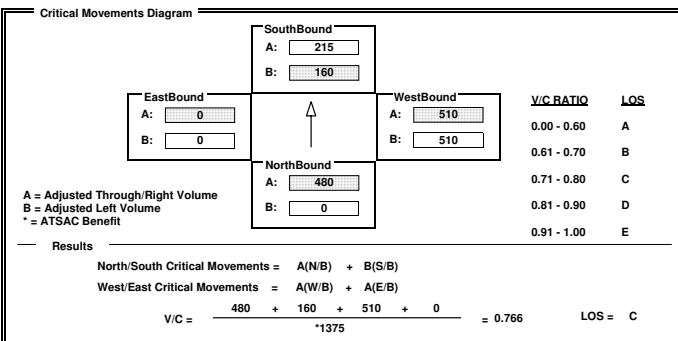

INTERSECTION DATA SUMMARY SHEET

N/S: La Cienega Blvd W/E: I-405 SB Ramps S/O Century I/S No: 97
AM/PM: AM Comments: Cumulative Adjusted (2013) No Project
COUNT DATE: STUDY DATE: GROWTH FACTOR:

Volume/Lane/Signal Configurations table with columns for Northbound, Southbound, Westbound, Eastbound and rows for Existing, Ambient, Related, Project, Total, Lane, and Signal.

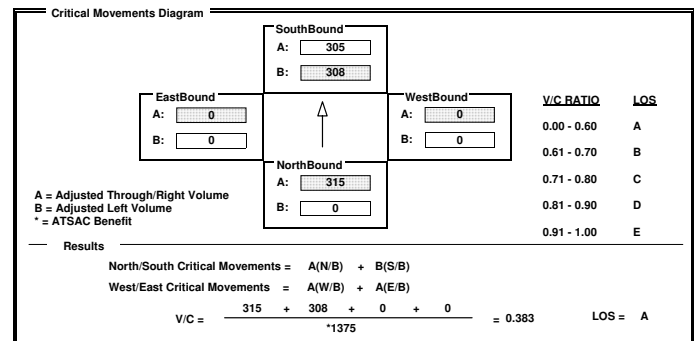

INTERSECTION DATA SUMMARY SHEET

N/S: W/E: I/S No:

AM/PM: Comments:

COUNT DATE: STUDY DATE: GROWTH FACTOR:

	NORTHBOUND			SOUTHBOUND			WESTBOUND			EASTBOUND		
	LT	TH	RT	LT	TH	RT	LT	TH	RT	LT	TH	RT
EXISTING	280	2480	50	110	2200	90	210	1220	310	10	420	130
AMBIENT												
RELATED												
PROJECT												
TOTAL	280	2480	50	110	2200	90	210	1220	310	10	420	130
LANE												
SIGNAL	Phasing		RTOR	Phasing		RTOR	Phasing		RTOR	Phasing		RTOR
	Prot-Fix		Auto	Prot-Fix		Auto	Prot-Fix		Auto	Perm		Auto

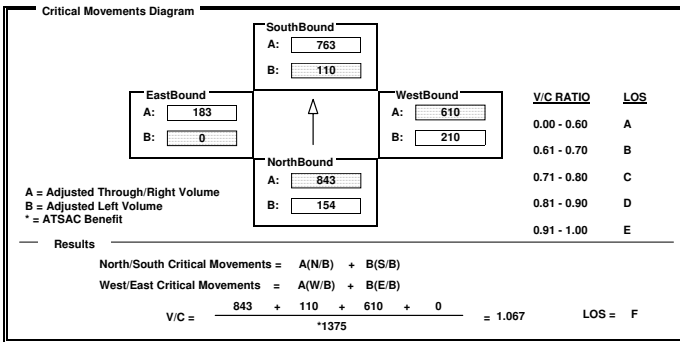

INTERSECTION DATA SUMMARY SHEET

N/S: W/E: I/S No:

AM/PM: Comments:

COUNT DATE: STUDY DATE: GROWTH FACTOR:

	NORTHBOUND			SOUTHBOUND			WESTBOUND			EASTBOUND		
	LT	TH	RT	LT	TH	RT	LT	TH	RT	LT	TH	RT
EXISTING	170	1500	120	80	690	70	220	1000	180	270	1430	90
AMBIENT												
RELATED												
PROJECT												
TOTAL	170	1500	120	80	690	70	220	1000	180	270	1430	90
LANE												
SIGNAL	Phasing		RTOR	Phasing		RTOR	Phasing		RTOR	Phasing		RTOR
	Perm		Auto	Prot-Fix		Auto	Prot-Fix		Auto	Prot-Fix		Auto

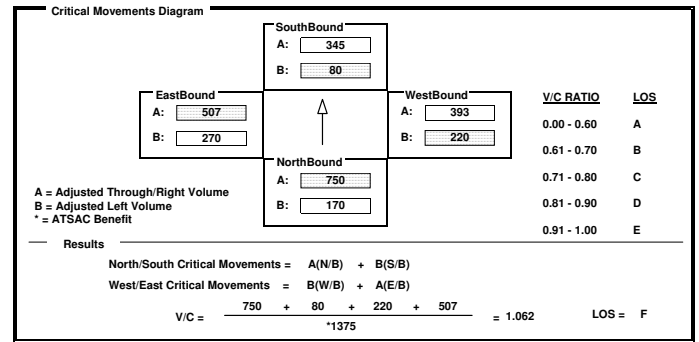

INTERSECTION DATA SUMMARY SHEET

N/S: W/E: I/S No:

AM/PM: Comments:

COUNT DATE: STUDY DATE: GROWTH FACTOR:

	NORTHBOUND			SOUTHBOUND			WESTBOUND			EASTBOUND		
	LT	TH	RT	LT	TH	RT	LT	TH	RT	LT	TH	RT
EXISTING	120	690	20	100	470	100	30	1000	160	160	470	70
AMBIENT												
RELATED												
PROJECT												
TOTAL	120	690	20	100	470	100	30	1000	160	160	470	70
LANE												
SIGNAL	Phasing		RTOR	Phasing		RTOR	Phasing		RTOR	Phasing		RTOR
	Prot-Fix		Auto	Prot-Fix		Auto	Prot-Fix		Auto	Prot-Fix		Auto

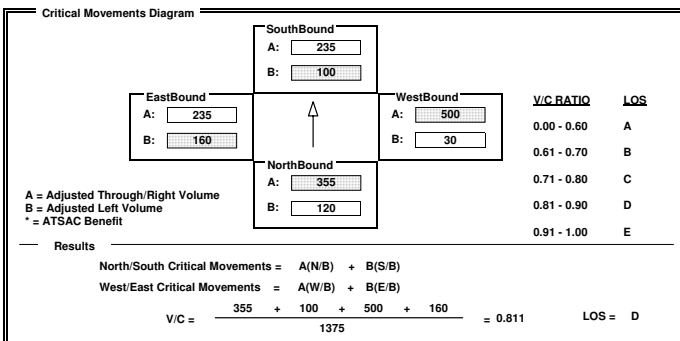

INTERSECTION DATA SUMMARY SHEET

N/S: W/E: I/S No:

AM/PM: Comments:

COUNT DATE: STUDY DATE: GROWTH FACTOR:

	NORTHBOUND			SOUTHBOUND			WESTBOUND			EASTBOUND		
	LT	TH	RT	LT	TH	RT	LT	TH	RT	LT	TH	RT
EXISTING	0	2290	790	150	0	0	1390	0	110	0	0	0
AMBIENT												
RELATED												
PROJECT												
TOTAL	0	2290	790	150	0	0	1390	0	110	0	0	0
LANE												
SIGNAL	Phasing		RTOR	Phasing		RTOR	Phasing		RTOR	Phasing		RTOR
	Prot-Fix		Auto	Prot-Fix		Auto	Split		Free	Prot-Fix		Auto

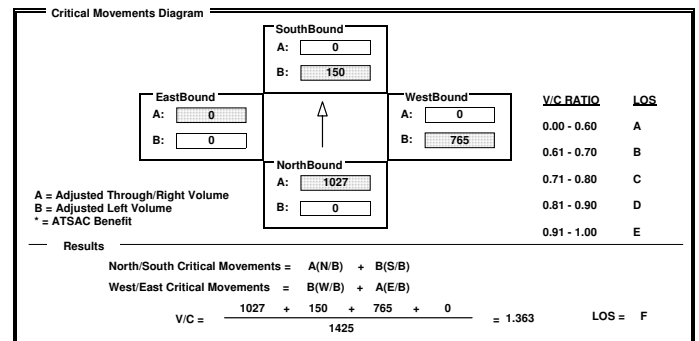

INTERSECTION DATA SUMMARY SHEET

N/S: Overland Ave W/E: Venice Blvd I/S No: 121
 AM/PM: AM Comments: Cumulative (2013) Adjusted W/O Project
 COUNT DATE: STUDY DATE: GROWTH FACTOR:

	NORTHBOUND			SOUTHBOUND			WESTBOUND			EASTBOUND		
	LT	TH	RT	LT	TH	RT	LT	TH	RT	LT	TH	RT
EXISTING	170	990	170	100	510	100	270	1540	220	240	1290	100
AMBIENT												
RELATED												
PROJECT												
TOTAL	170	990	170	100	510	100	270	1540	220	240	1290	100
LANE	1	2	1	1	2	1	2	2	1	2	2	1
SIGNAL	Prot-Fix	OLA	Prot-Fix	OLA	Prot-Fix	OLA	Prot-Fix	Auto	Prot-Fix	Auto	Prot-Fix	Auto

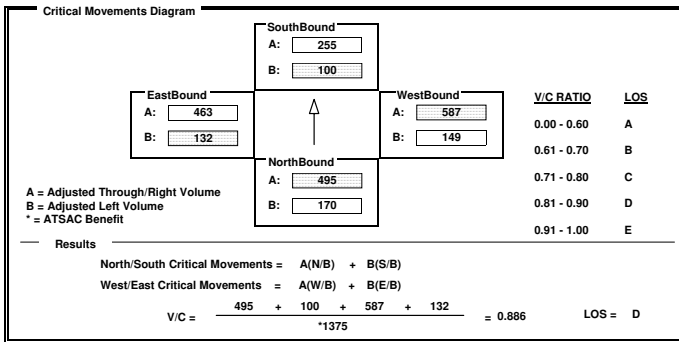

INTERSECTION DATA SUMMARY SHEET

N/S: Lincoln Blvd W/E: Rose Ave I/S No: 160
 AM/PM: AM Comments: Cumulative (2013) Adjusted W/O Project
 COUNT DATE: STUDY DATE: GROWTH FACTOR:

	NORTHBOUND			SOUTHBOUND			WESTBOUND			EASTBOUND		
	LT	TH	RT	LT	TH	RT	LT	TH	RT	LT	TH	RT
EXISTING	120	1750	20	100	1130	150	60	330	200	210	300	140
AMBIENT												
RELATED												
PROJECT												
TOTAL	120	1750	20	100	1130	150	60	330	200	210	300	140
LANE	1	2	1	1	2	1	1	1	1	1	1	1
SIGNAL	Perm	Auto	Perm	Auto	Perm	Auto	Perm	Auto	Perm	Auto	Perm	Auto

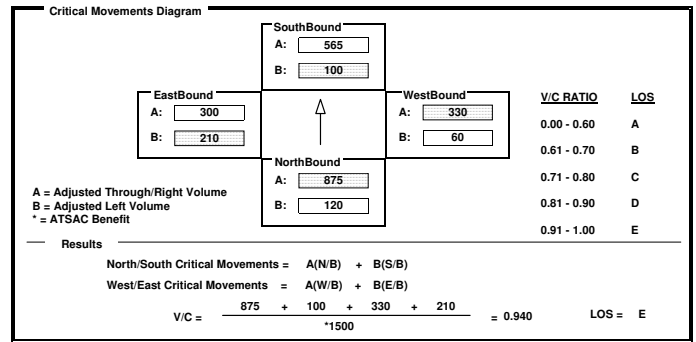

INTERSECTION DATA SUMMARY SHEET

N/S: Western Ave W/E: Century Blvd I/S No: 161
 AM/PM: AM Comments: Cumulative (2013) Adjusted W/O Project
 COUNT DATE: STUDY DATE: GROWTH FACTOR:

	NORTHBOUND			SOUTHBOUND			WESTBOUND			EASTBOUND		
	LT	TH	RT	LT	TH	RT	LT	TH	RT	LT	TH	RT
EXISTING	100	1010	170	100	950	130	170	1110	150	140	620	140
AMBIENT												
RELATED												
PROJECT												
TOTAL	100	1010	170	100	950	130	170	1110	150	140	620	140
LANE	1	2	1	1	1	1	1	2	1	1	2	1
SIGNAL	Prot-Fix	OLA	Prot-Fix	Auto	Prot-Fix	Auto	Prot-Fix	Auto	Prot-Fix	Auto	Prot-Fix	Auto

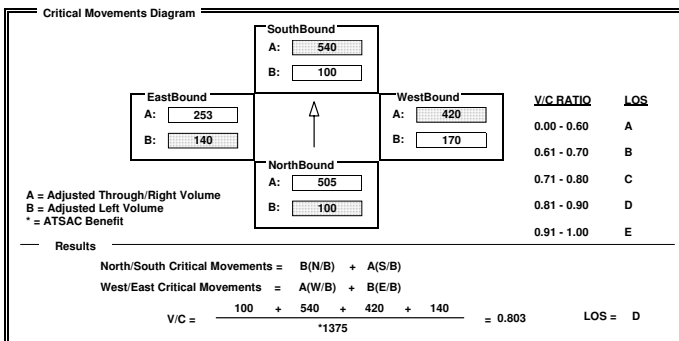

INTERSECTION DATA SUMMARY SHEET

N/S: La Cienega Blvd W/E: Jefferson Blvd I/S No: 200
 AM/PM: AM Comments: Cumulative (2013) Adjusted W/O Project
 COUNT DATE: STUDY DATE: GROWTH FACTOR:

	NORTHBOUND			SOUTHBOUND			WESTBOUND			EASTBOUND		
	LT	TH	RT	LT	TH	RT	LT	TH	RT	LT	TH	RT
EXISTING	90	2460	130	60	2070	670	330	1170	140	450	570	120
AMBIENT												
RELATED												
PROJECT												
TOTAL	90	2460	130	60	2070	670	330	1170	140	450	570	120
LANE	1	2	1	1	3	1	2	2	1	2	1	1
SIGNAL	Perm	Auto	Perm	OLA	Prot-Fix	Auto	Prot-Fix	Auto	Prot-Fix	Auto	Prot-Fix	Auto

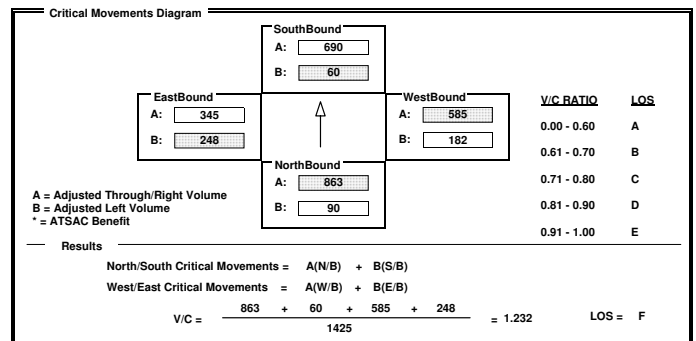

INTERSECTION DATA SUMMARY SHEET

N/S: W/E: I/S No:

AM/PM: Comments:

COUNT DATE: STUDY DATE: GROWTH FACTOR:

Volume/Lane/Signal Configurations

	NORTHBOUND			SOUTHBOUND			WESTBOUND			EASTBOUND		
	LT	TH	RT	LT	TH	RT	LT	TH	RT	LT	TH	RT
EXISTING	220	770	150	110	670	100	190	470	140	100	470	110
AMBIENT												
RELATED												
PROJECT												
TOTAL	220	770	150	110	670	100	190	470	140	100	470	110
LANE	1	2	1	1	3	1	1	1	1	1	2	1
SIGNAL	Prot-Fix		Auto	Prot-Fix		Auto	Prot-Fix		Auto	Prot-Fix		Auto

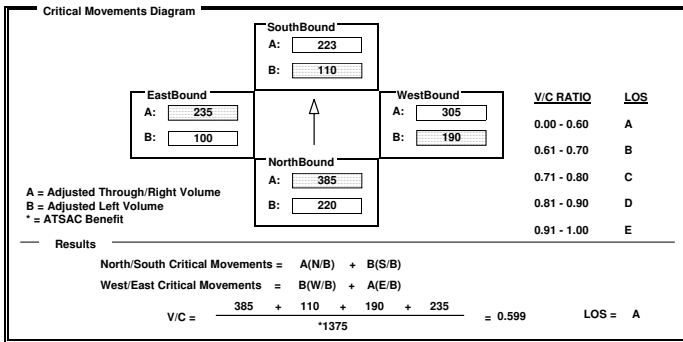

INTERSECTION DATA SUMMARY SHEET

N/S: W/E: I/S No:

AM/PM: Comments:

COUNT DATE: STUDY DATE: GROWTH FACTOR:

Volume/Lane/Signal Configurations

	NORTHBOUND			SOUTHBOUND			WESTBOUND			EASTBOUND		
	LT	TH	RT	LT	TH	RT	LT	TH	RT	LT	TH	RT
EXISTING	20	50	40	380	20	430	70	1620	440	700	1590	30
AMBIENT												
RELATED												
PROJECT												
TOTAL	20	50	40	380	20	430	70	1620	440	700	1590	30
LANE	1	2	1	2	1	1	1	4	1	2	4	1
SIGNAL	Split		Auto	Split		Auto	Prot-Fix		OLA	Prot-Fix		Auto

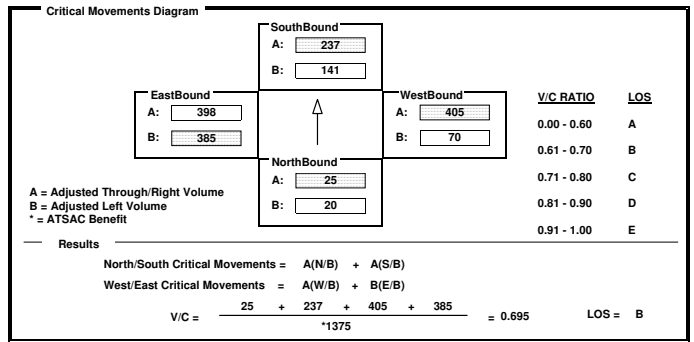

INTERSECTION DATA SUMMARY SHEET

N/S: W/E: I/S No:

AM/PM: Comments:

COUNT DATE: STUDY DATE: GROWTH FACTOR:

Volume/Lane/Signal Configurations

	NORTHBOUND			SOUTHBOUND			WESTBOUND			EASTBOUND		
	LT	TH	RT	LT	TH	RT	LT	TH	RT	LT	TH	RT
EXISTING	50	50	680	80	120	20	590	840	30	30	520	20
AMBIENT												
RELATED												
PROJECT												
TOTAL	50	50	680	80	120	20	590	840	30	30	520	20
LANE	1	2	1	1	3	1	2	1	1	1	2	1
SIGNAL	Split		OLA	Split		Auto	Prot-Fix		Auto	Prot-Fix		Auto

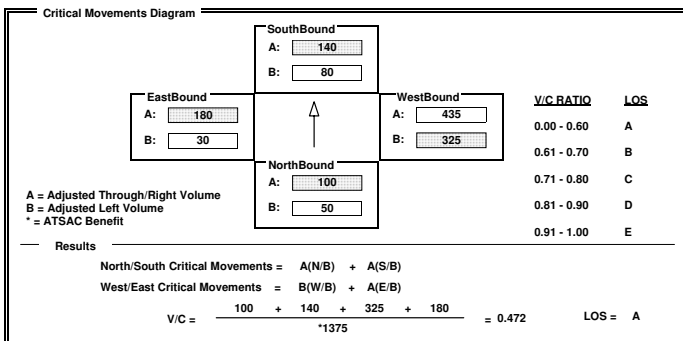

INTERSECTION DATA SUMMARY SHEET

N/S: W/E: I/S No:

AM/PM: Comments:

COUNT DATE: STUDY DATE: GROWTH FACTOR:

Volume/Lane/Signal Configurations

	NORTHBOUND			SOUTHBOUND			WESTBOUND			EASTBOUND		
	LT	TH	RT	LT	TH	RT	LT	TH	RT	LT	TH	RT
EXISTING	120	700	340	70	610	30	130	850	60	30	1070	70
AMBIENT												
RELATED												
PROJECT												
TOTAL	120	700	340	70	610	30	130	850	60	30	1070	70
LANE	1	2	1	1	1	1	1	2	1	1	2	1
SIGNAL	Prot-Fix		Auto	Prot-Fix		Auto	Prot-Fix		Auto	Prot-Fix		Auto

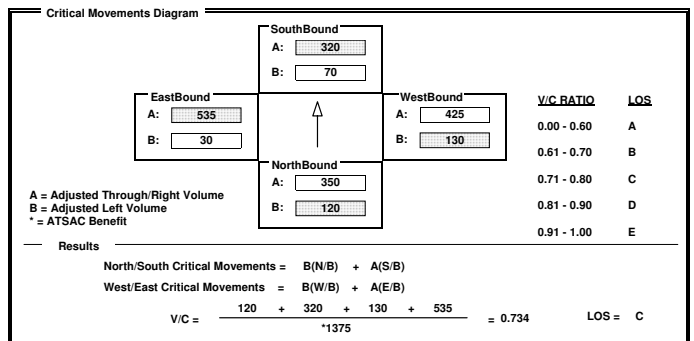

INTERSECTION DATA SUMMARY SHEET

N/S: W/E: I/S No:

AM/PM: Comments:

COUNT DATE: STUDY DATE: GROWTH FACTOR:

Volume/Lane/Signal Configurations

	NORTHBOUND			SOUTHBOUND			WESTBOUND			EASTBOUND		
	LT	TH	RT	LT	TH	RT	LT	TH	RT	LT	TH	RT
EXISTING	230	490	120	160	320	130	90	530	80	100	470	170
AMBIENT												
RELATED												
PROJECT												
TOTAL	230	490	120	160	320	130	90	530	80	100	470	170
LANE	1	2	1	1	1	1	1	1	1	1	1	1
SIGNAL	Phasing: Perm	RTOR: Auto		Phasing: Perm	RTOR: Auto		Phasing: Perm	RTOR: Auto		Phasing: Perm	RTOR: Auto	

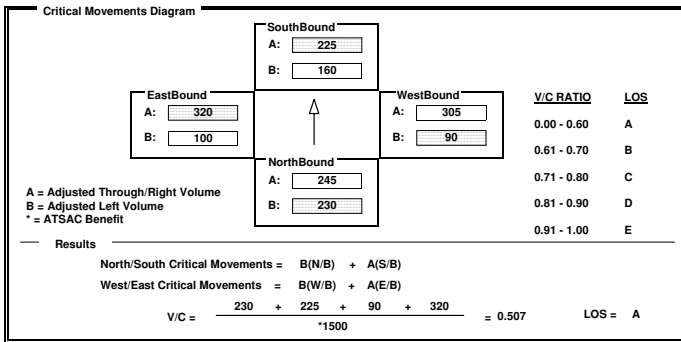

INTERSECTION DATA SUMMARY SHEET

N/S: W/E: I/S No:

AM/PM: Comments:

COUNT DATE: STUDY DATE: GROWTH FACTOR:

Volume/Lane/Signal Configurations

	NORTHBOUND			SOUTHBOUND			WESTBOUND			EASTBOUND		
	LT	TH	RT	LT	TH	RT	LT	TH	RT	LT	TH	RT
EXISTING	430	470	130	130	330	190	120	1640	170	190	1730	390
AMBIENT												
RELATED												
PROJECT												
TOTAL	430	470	130	130	330	190	120	1640	170	190	1730	390
LANE	2	1	1	2	2	1	1	3	1	1	3	1
SIGNAL	Phasing: Prot-Fix	RTOR: Auto		Phasing: Prot-Fix	RTOR: OLA		Phasing: Prot-Fix	RTOR: Auto		Phasing: Prot-Fix	RTOR: Auto	

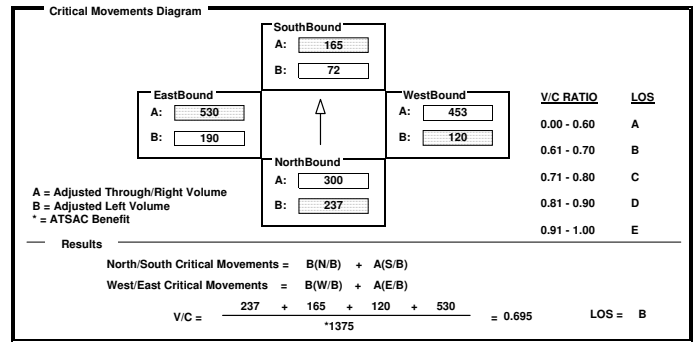

INTERSECTION DATA SUMMARY SHEET

N/S: W/E: I/S No:

AM/PM: Comments:

COUNT DATE: STUDY DATE: GROWTH FACTOR:

Volume/Lane/Signal Configurations

	NORTHBOUND			SOUTHBOUND			WESTBOUND			EASTBOUND		
	LT	TH	RT	LT	TH	RT	LT	TH	RT	LT	TH	RT
EXISTING	150	400	190	500	250	130	150	510	430	210	470	180
AMBIENT												
RELATED												
PROJECT												
TOTAL	150	400	190	500	250	130	150	510	430	210	470	180
LANE	2	2	1	2	2	1	2	3	1	2	2	1
SIGNAL	Phasing: Prot-Fix	RTOR: OLA		Phasing: Prot-Fix	RTOR: OLA		Phasing: Prot-Fix	RTOR: OLA		Phasing: Prot-Fix	RTOR: Auto	

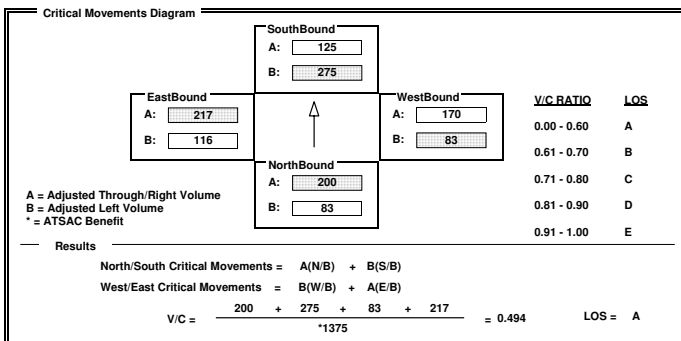

INTERSECTION DATA SUMMARY SHEET

N/S: W/E: I/S No:

AM/PM: Comments:

COUNT DATE: STUDY DATE: GROWTH FACTOR:

Volume/Lane/Signal Configurations

	NORTHBOUND			SOUTHBOUND			WESTBOUND			EASTBOUND		
	LT	TH	RT	LT	TH	RT	LT	TH	RT	LT	TH	RT
EXISTING	100	1310	10	60	1380	350	10	10	20	270	10	60
AMBIENT												
RELATED												
PROJECT												
TOTAL	100	1310	10	60	1380	350	10	10	20	270	10	60
LANE	1	2	1	1	2	1		1		1	1	1
SIGNAL	Phasing: Prot-Fix	RTOR: Auto		Phasing: Prot-Fix	RTOR: Auto		Phasing: Prot-Fix	RTOR: Auto		Phasing: Prot-Fix	RTOR: Auto	

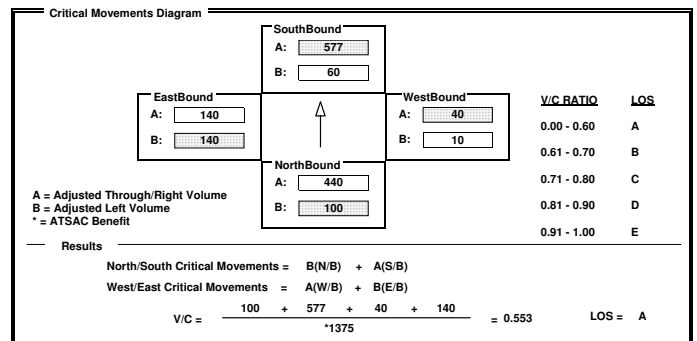

INTERSECTION DATA SUMMARY SHEET

N/S: Lincoln Blv W/E: Bluff Creek Dr I/S No: 22
 AM/PM: MD Comments: No Project
 COUNT DATE: STUDY DATE: GROWTH FACTOR:

	NORTHBOUND			SOUTHBOUND			WESTBOUND			EASTBOUND		
	LT	TH	RT	LT	TH	RT	LT	TH	RT	LT	TH	RT
EXISTING	0	1570	90	340	1680	0	230	0	70	0	0	0
AMBIENT												
RELATED												
PROJECT												
TOTAL	0	1570	90	340	1680	0	230	0	70	0	0	0
LANE	[Icons]			[Icons]			[Icons]			[Icons]		
SIGNAL	Phasing RTOR		Phasing RTOR		Phasing RTOR		Phasing RTOR		Phasing RTOR		Phasing RTOR	
	Perm Auto		Prot-Fix Auto		Split Auto		Split Auto		Prot-Fix Auto		Prot-Fix Auto	

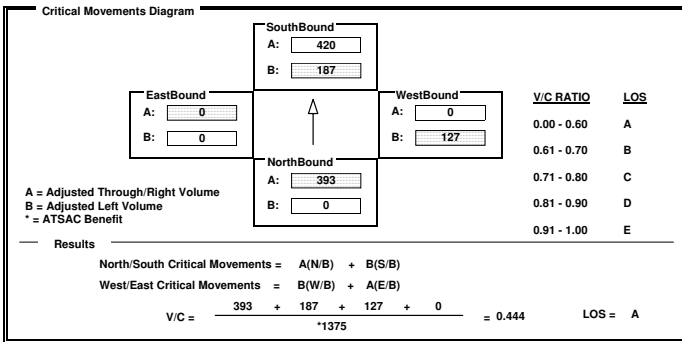

INTERSECTION DATA SUMMARY SHEET

N/S: La Tijera Blvd W/E: Centinela Ave I/S No: 27
 AM/PM: MD Comments: No Project
 COUNT DATE: STUDY DATE: GROWTH FACTOR:

	NORTHBOUND			SOUTHBOUND			WESTBOUND			EASTBOUND		
	LT	TH	RT	LT	TH	RT	LT	TH	RT	LT	TH	RT
EXISTING	190	760	180	90	760	140	430	680	20	210	590	100
AMBIENT												
RELATED												
PROJECT												
TOTAL	190	760	180	90	760	140	430	680	20	210	590	100
LANE	[Icons]			[Icons]			[Icons]			[Icons]		
SIGNAL	Phasing RTOR		Phasing RTOR		Phasing RTOR		Phasing RTOR		Phasing RTOR		Phasing RTOR	
	Prot-Fix Auto		Prot-Fix Auto		Prot-Fix Auto		Prot-Fix Auto		Prot-Fix Auto		Prot-Fix Auto	

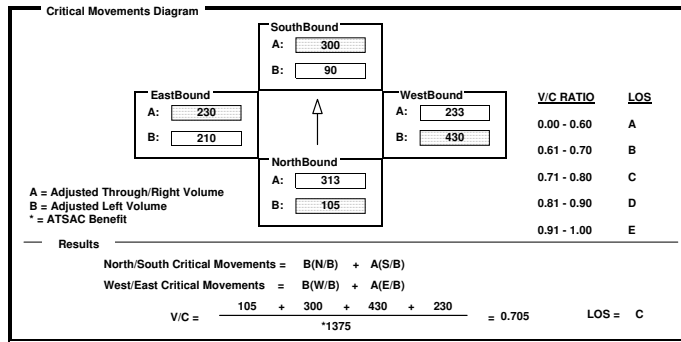

INTERSECTION DATA SUMMARY SHEET

N/S: La Cienega Blvd W/E: Century Blvd I/S No: 36
 AM/PM: MD Comments: No Project
 COUNT DATE: STUDY DATE: GROWTH FACTOR:

	NORTHBOUND			SOUTHBOUND			WESTBOUND			EASTBOUND		
	LT	TH	RT	LT	TH	RT	LT	TH	RT	LT	TH	RT
EXISTING	160	270	410	390	470	820	170	1050	360	130	1210	600
AMBIENT												
RELATED												
PROJECT												
TOTAL	160	270	410	390	470	820	170	1050	360	130	1210	600
LANE	[Icons]			[Icons]			[Icons]			[Icons]		
SIGNAL	Phasing RTOR		Phasing RTOR		Phasing RTOR		Phasing RTOR		Phasing RTOR		Phasing RTOR	
	Prot-Fix OLA		Prot-Fix OLA		Prot-Fix Auto		Prot-Fix OLA		Prot-Fix OLA		Prot-Fix OLA	

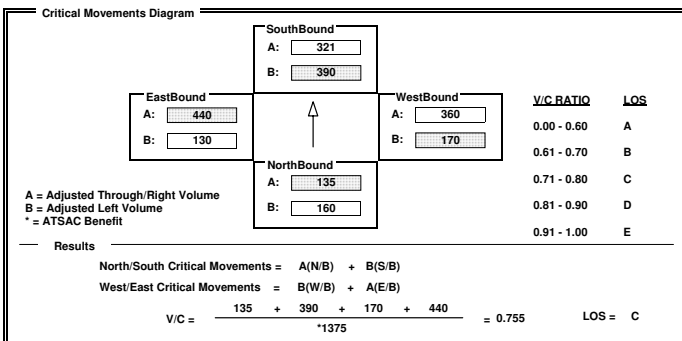

INTERSECTION DATA SUMMARY SHEET

N/S: Sepulveda Blvd W/E: Century Blvd I/S No: 38
 AM/PM: MD Comments: No Project
 COUNT DATE: STUDY DATE: GROWTH FACTOR:

	NORTHBOUND			SOUTHBOUND			WESTBOUND			EASTBOUND		
	LT	TH	RT	LT	TH	RT	LT	TH	RT	LT	TH	RT
EXISTING	0	2930	20	0	1560	270	500	100	290	0	0	0
AMBIENT												
RELATED												
PROJECT												
TOTAL	0	2930	20	0	1560	270	500	100	290	0	0	0
LANE	[Icons]			[Icons]			[Icons]			[Icons]		
SIGNAL	Phasing RTOR		Phasing RTOR		Phasing RTOR		Phasing RTOR		Phasing RTOR		Phasing RTOR	
	Perm Free		Perm Auto		Split Auto		<none>		Auto		Auto	

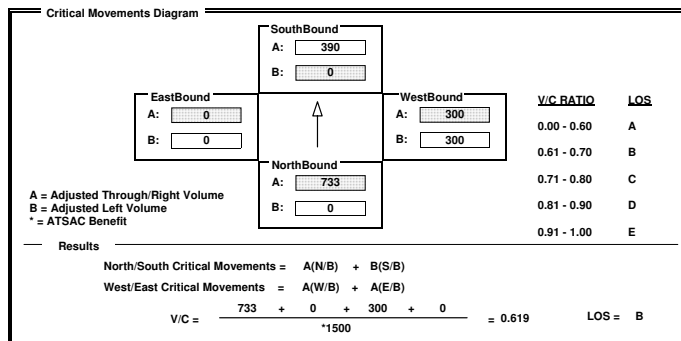

INTERSECTION DATA SUMMARY SHEET

N/S: W/E: I/S No:

AM/PM: Comments:

COUNT DATE: STUDY DATE: GROWTH FACTOR:

	NORTHBOUND			SOUTHBOUND			WESTBOUND			EASTBOUND		
	LT	TH	RT	LT	TH	RT	LT	TH	RT	LT	TH	RT
EXISTING	80	20	170	80	20	50	90	620	40	60	810	50
AMBIENT												
RELATED												
PROJECT												
TOTAL	80	20	170	80	20	50	90	620	40	60	810	50
LANE	1	1	2	1	1	1	2	2	1	1	2	1
SIGNAL	Phasing		RTOR	Phasing		RTOR	Phasing		RTOR	Phasing		RTOR
	Split		OLA	Split		Auto	Prot-Fix		Auto	Prot-Fix		Auto

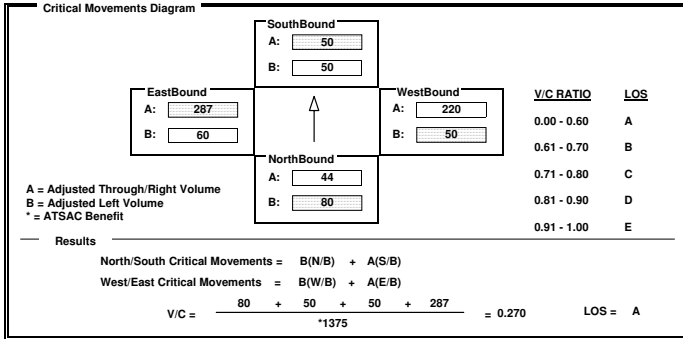

INTERSECTION DATA SUMMARY SHEET

N/S: W/E: I/S No:

AM/PM: Comments:

COUNT DATE: STUDY DATE: GROWTH FACTOR:

	NORTHBOUND			SOUTHBOUND			WESTBOUND			EASTBOUND		
	LT	TH	RT	LT	TH	RT	LT	TH	RT	LT	TH	RT
EXISTING	610	1540	50	80	1900	100	20	20	40	110	30	840
AMBIENT												
RELATED												
PROJECT												
TOTAL	610	1540	50	80	1900	100	20	20	40	110	30	840
LANE	2	2	1	1	2	1	1	1	1	1	1	1
SIGNAL	Phasing		RTOR	Phasing		RTOR	Phasing		RTOR	Phasing		RTOR
	Prot-Fix		Auto	Prot-Fix		Auto	Perm		Auto	Perm		Free

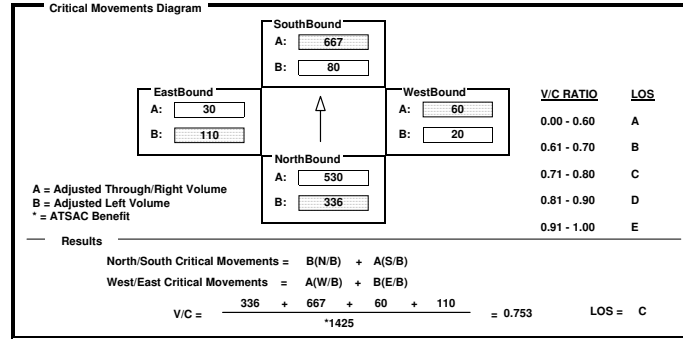

INTERSECTION DATA SUMMARY SHEET

N/S: W/E: I/S No:

AM/PM: Comments:

COUNT DATE: STUDY DATE: GROWTH FACTOR:

	NORTHBOUND			SOUTHBOUND			WESTBOUND			EASTBOUND		
	LT	TH	RT	LT	TH	RT	LT	TH	RT	LT	TH	RT
EXISTING	0	1200	710	520	1250	0	570	0	240	0	0	0
AMBIENT												
RELATED												
PROJECT												
TOTAL	0	1200	710	520	1250	0	570	0	240	0	0	0
LANE		4	1	2	3		3		1			
SIGNAL	Phasing		RTOR	Phasing		RTOR	Phasing		RTOR	Phasing		RTOR
	<none>		Free	Prot-Fix		Auto	Split		Auto	<none>		<none>

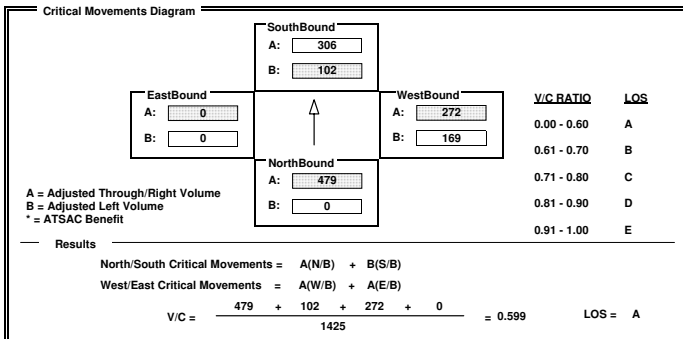

INTERSECTION DATA SUMMARY SHEET

N/S: W/E: I/S No:

AM/PM: Comments:

COUNT DATE: STUDY DATE: GROWTH FACTOR:

	NORTHBOUND			SOUTHBOUND			WESTBOUND			EASTBOUND		
	LT	TH	RT	LT	TH	RT	LT	TH	RT	LT	TH	RT
EXISTING	130	220	220	150	210	270	50	390	240	190	370	150
AMBIENT												
RELATED												
PROJECT												
TOTAL	130	220	220	150	210	270	50	390	240	190	370	150
LANE	2	1	1	2	1	1	2	3	2	2	3	2
SIGNAL	Phasing		RTOR	Phasing		RTOR	Phasing		RTOR	Phasing		RTOR
	Prot-Fix		Auto	Prot-Fix		Auto	Prot-Fix		OLA	Prot-Fix		OLA

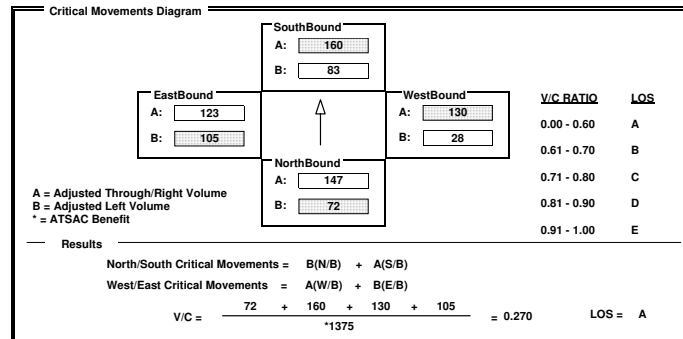

INTERSECTION DATA SUMMARY SHEET

N/S: W/E: I/S No:

AM/PM: Comments:

COUNT DATE: STUDY DATE: GROWTH FACTOR:

	NORTHBOUND			SOUTHBOUND			WESTBOUND			EASTBOUND		
	LT	TH	RT	LT	TH	RT	LT	TH	RT	LT	TH	RT
EXISTING	170	1280	910	560	1810	100	190	330	290	430	280	160
AMBIENT												
RELATED												
PROJECT												
TOTAL	170	1280	910	560	1810	100	190	330	290	430	280	160
LANE	1	3	1	2	3	1	2	2	2	2	3	1
Phasing	Prot-Fix		Auto	Prot-Fix		Auto	Prot-Fix		OLA	Prot-Fix		Auto
SIGNAL	Prot-Fix		Auto	Prot-Fix		Auto	Prot-Fix		OLA	Prot-Fix		Auto

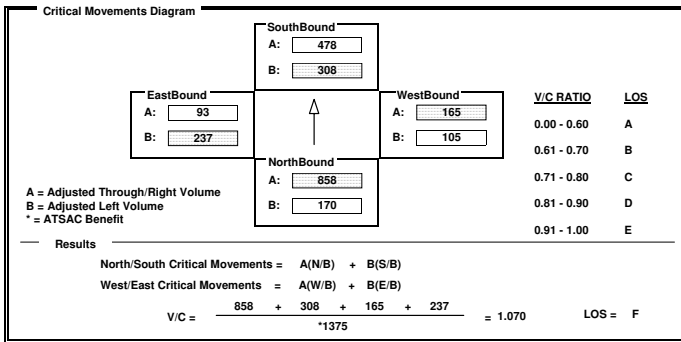

INTERSECTION DATA SUMMARY SHEET

N/S: W/E: I/S No:

AM/PM: Comments:

COUNT DATE: STUDY DATE: GROWTH FACTOR:

	NORTHBOUND			SOUTHBOUND			WESTBOUND			EASTBOUND		
	LT	TH	RT	LT	TH	RT	LT	TH	RT	LT	TH	RT
EXISTING	40	0	70	70	370	210	90	760	0	0	680	60
AMBIENT												
RELATED												
PROJECT												
TOTAL	40	0	70	70	370	210	90	760	0	0	680	60
LANE	1			2	1	1	1	1	1	2	3	1
Phasing	Split		Auto	Split		Auto	Prot-Fix		Auto	Perm		Auto
SIGNAL	Split		Auto	Split		Auto	Prot-Fix		Auto	Perm		Auto

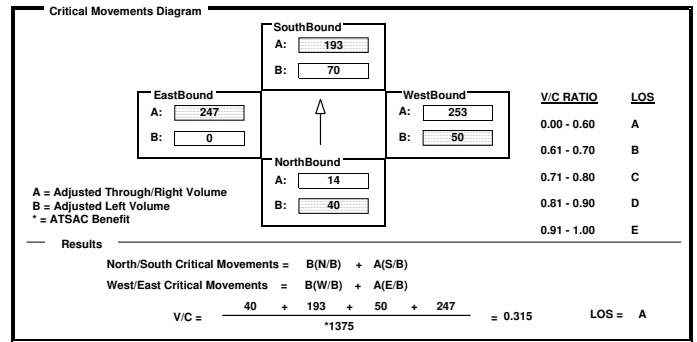

INTERSECTION DATA SUMMARY SHEET

N/S: W/E: I/S No:

AM/PM: Comments:

COUNT DATE: STUDY DATE: GROWTH FACTOR:

	NORTHBOUND			SOUTHBOUND			WESTBOUND			EASTBOUND		
	LT	TH	RT	LT	TH	RT	LT	TH	RT	LT	TH	RT
EXISTING	530	0	560	0	0	0	240	560	0	0	240	700
AMBIENT												
RELATED												
PROJECT												
TOTAL	530	0	560	0	0	0	240	560	0	0	240	700
LANE	2		2				2	2		2	1	1
Phasing	Split		OLA	<none>		<none>	Prot-Fix		Auto	Perm		OLA
SIGNAL	Split		OLA	<none>		<none>	Prot-Fix		Auto	Perm		OLA

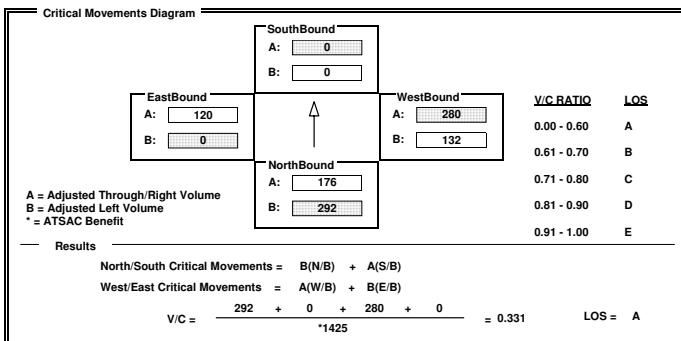

INTERSECTION DATA SUMMARY SHEET

N/S: W/E: I/S No:

AM/PM: Comments:

COUNT DATE: STUDY DATE: GROWTH FACTOR:

	NORTHBOUND			SOUTHBOUND			WESTBOUND			EASTBOUND		
	LT	TH	RT	LT	TH	RT	LT	TH	RT	LT	TH	RT
EXISTING	20	1380	240	920	1550	290	410	100	780	100	150	60
AMBIENT												
RELATED												
PROJECT												
TOTAL	20	1380	240	920	1550	290	410	100	780	100	150	60
LANE	1	4	1	2	3	1	2	2	2	1	2	1
Phasing	Prot-Fix		OLA	Prot-Fix		OLA	Prot-Fix		OLA	Prot-Fix		Auto
SIGNAL	Prot-Fix		OLA	Prot-Fix		OLA	Prot-Fix		OLA	Prot-Fix		Auto

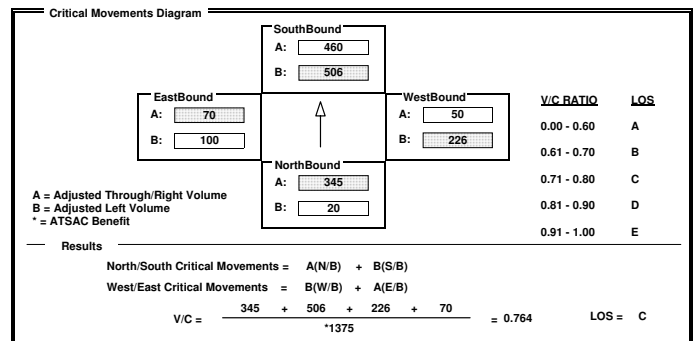

INTERSECTION DATA SUMMARY SHEET

N/S: La Cienega Blvd W/E: La Tijera Blvd I/S No: 88
AM/PM: MD Comments: No Project
COUNT DATE: STUDY DATE: GROWTH FACTOR:

Volume/Lane/Signal Configurations table with columns for Northbound, Southbound, Westbound, Eastbound and rows for Existing, Ambient, Related, Project, Total, Lane, and Signal.

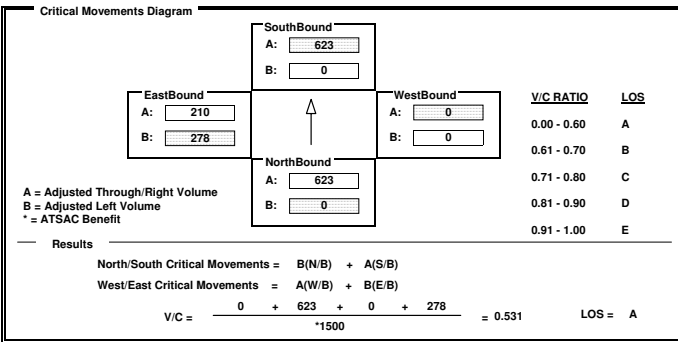

INTERSECTION DATA SUMMARY SHEET

N/S: Lincoln Blvd W/E: La Tijera Blvd I/S No: 99
AM/PM: MD Comments: No Project
COUNT DATE: STUDY DATE: GROWTH FACTOR:

Volume/Lane/Signal Configurations table with columns for Northbound, Southbound, Westbound, Eastbound and rows for Existing, Ambient, Related, Project, Total, Lane, and Signal.

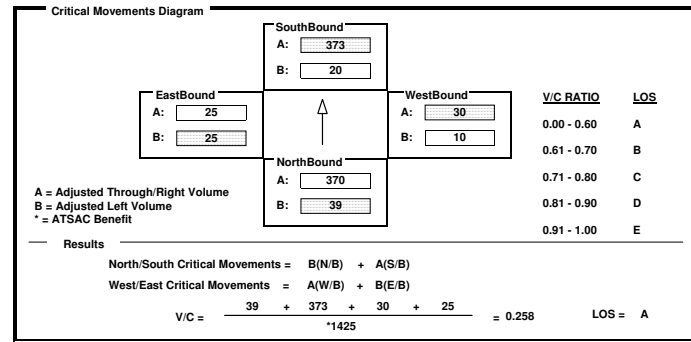

INTERSECTION DATA SUMMARY SHEET

N/S: La Tijera W/E: Manchester Ave I/S No: 100
AM/PM: MD Comments: No Project
COUNT DATE: STUDY DATE: GROWTH FACTOR:

Volume/Lane/Signal Configurations table with columns for Northbound, Southbound, Westbound, Eastbound and rows for Existing, Ambient, Related, Project, Total, Lane, and Signal.

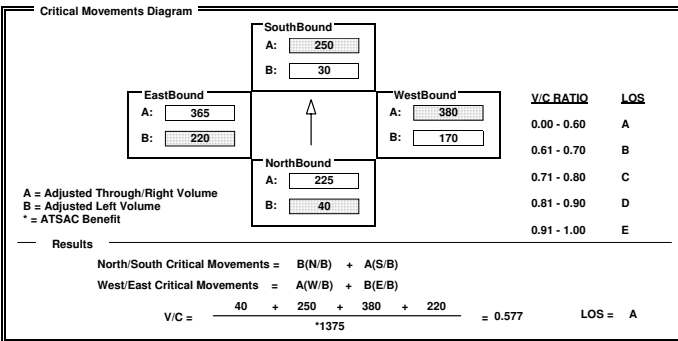

INTERSECTION DATA SUMMARY SHEET

N/S: Sepulveda Blvd W/E: La Tijera Blvd I/S No: 101
AM/PM: MD Comments: No Project
COUNT DATE: STUDY DATE: GROWTH FACTOR:

Volume/Lane/Signal Configurations table with columns for Northbound, Southbound, Westbound, Eastbound and rows for Existing, Ambient, Related, Project, Total, Lane, and Signal.

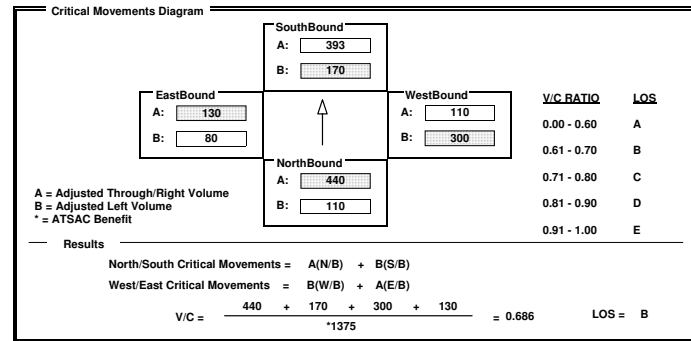

INTERSECTION DATA SUMMARY SHEET

N/S: W/E: I/S No:
 AM/PM: Comments:
 COUNT DATE: STUDY DATE: GROWTH FACTOR:

	NORTHBOUND			SOUTHBOUND			WESTBOUND			EASTBOUND		
	LT	TH	RT	LT	TH	RT	LT	TH	RT	LT	TH	RT
EXISTING	250	0	250	0	0	0	0	1160	240	440	940	0
AMBIENT												
RELATED												
PROJECT												
TOTAL	250	0	250	0	0	0	0	1160	240	440	940	0
LANE	1 1 1			1 1 1			5 1 1			2 3 1		
SIGNAL	Phasing		RTOR	Phasing		RTOR	Phasing		RTOR	Phasing		RTOR
	Split		Auto	<none>		<none>	Perm		Auto	Prot-Fix		<none>

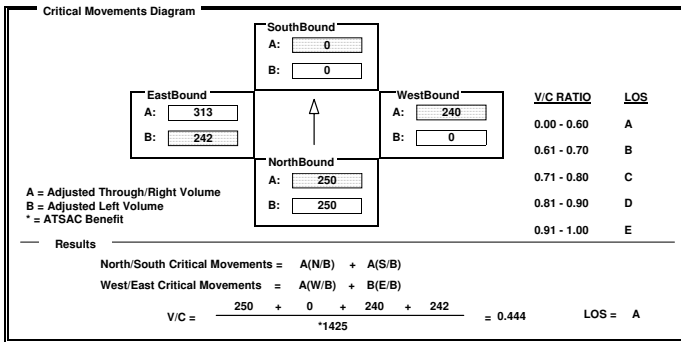

INTERSECTION DATA SUMMARY SHEET

N/S: W/E: I/S No:
 AM/PM: Comments:
 COUNT DATE: STUDY DATE: GROWTH FACTOR:

	NORTHBOUND			SOUTHBOUND			WESTBOUND			EASTBOUND		
	LT	TH	RT	LT	TH	RT	LT	TH	RT	LT	TH	RT
EXISTING	0	0	0	180	0	480	250	1160	0	0	1200	230
AMBIENT												
RELATED												
PROJECT												
TOTAL	0	0	0	180	0	480	250	1160	0	0	1200	230
LANE	1 1 1			1 1 1			2 3 1			1 4 1		
SIGNAL	Phasing		RTOR	Phasing		RTOR	Phasing		RTOR	Phasing		RTOR
	<none>		<none>	Split		<none>	Prot-Fix		<none>	Perm		Auto

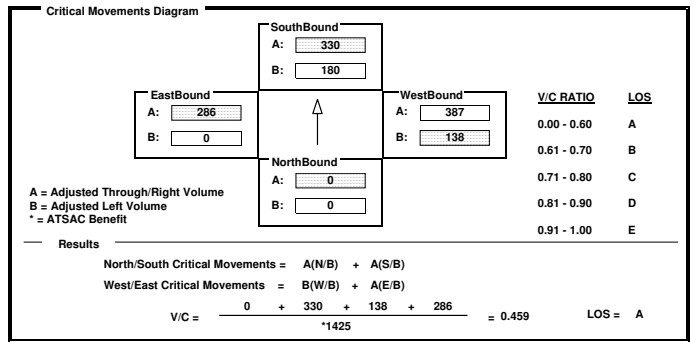

INTERSECTION DATA SUMMARY SHEET

N/S: W/E: I/S No:
 AM/PM: Comments:
 COUNT DATE: STUDY DATE: GROWTH FACTOR:

	NORTHBOUND			SOUTHBOUND			WESTBOUND			EASTBOUND		
	LT	TH	RT	LT	TH	RT	LT	TH	RT	LT	TH	RT
EXISTING	10	1530	120	140	1740	30	100	10	100	30	10	20
AMBIENT												
RELATED												
PROJECT												
TOTAL	10	1530	120	140	1740	30	100	10	100	30	10	20
LANE	1 4 1			2 3 1			1 1 1			1 1 1		
SIGNAL	Phasing		RTOR	Phasing		RTOR	Phasing		RTOR	Phasing		RTOR
	Prot-Fix		OLA	Prot-Fix		Auto	Perm		OLA	Perm		Auto

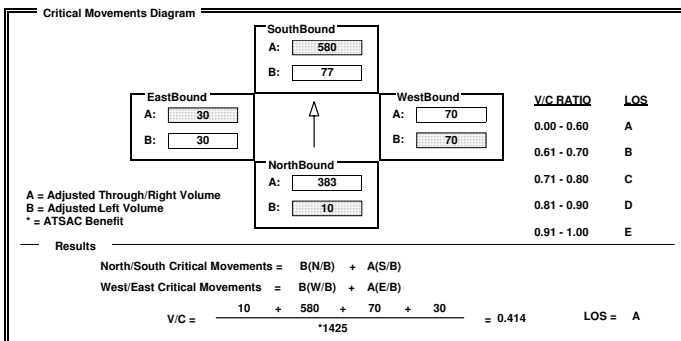

INTERSECTION DATA SUMMARY SHEET

N/S: W/E: I/S No:
 AM/PM: Comments:
 COUNT DATE: STUDY DATE: GROWTH FACTOR:

	NORTHBOUND			SOUTHBOUND			WESTBOUND			EASTBOUND		
	LT	TH	RT	LT	TH	RT	LT	TH	RT	LT	TH	RT
EXISTING	70	980	140	200	940	130	210	340	250	130	250	80
AMBIENT												
RELATED												
PROJECT												
TOTAL	70	980	140	200	940	130	210	340	250	130	250	80
LANE	1 3 1			1 2 1			2 2 1			2 2 1		
SIGNAL	Phasing		RTOR	Phasing		RTOR	Phasing		RTOR	Phasing		RTOR
	Prot-Fix		Auto	Prot-Fix		Auto	Prot-Fix		OLA	Prot-Fix		OLA

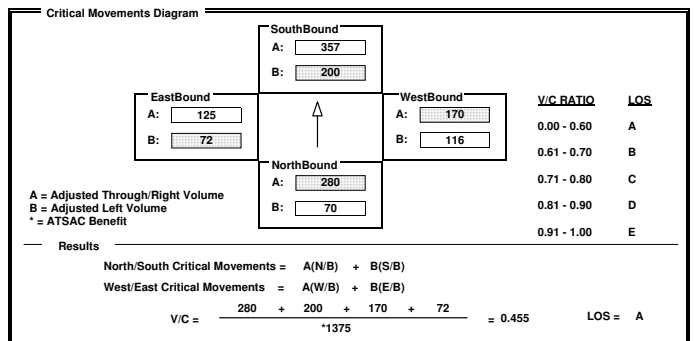

INTERSECTION DATA SUMMARY SHEET

N/S: Lincoln Blvd W/E: Marina Pointe Dr/ Maxella Ave I/S No: 106
AM/PM: MD Comments: No Project
COUNT DATE: STUDY DATE: GROWTH FACTOR:

Volume/Lane/Signal Configurations table with columns for Northbound, Southbound, Westbound, Eastbound and rows for Existing, Ambient, Related, Project, Total, Lane, Phasing, RTOR, Signal.

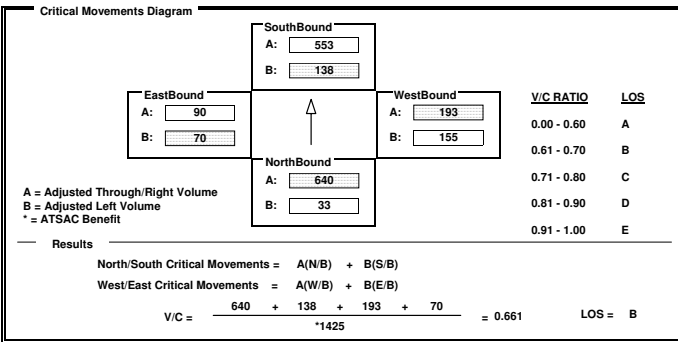

INTERSECTION DATA SUMMARY SHEET

N/S: Lincoln Blvd W/E: Mindanao Way I/S No: 107
AM/PM: MD Comments: No Project
COUNT DATE: STUDY DATE: GROWTH FACTOR:

Volume/Lane/Signal Configurations table with columns for Northbound, Southbound, Westbound, Eastbound and rows for Existing, Ambient, Related, Project, Total, Lane, Phasing, RTOR, Signal.

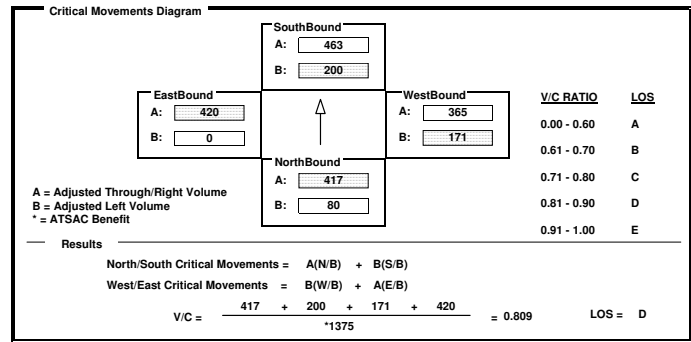

INTERSECTION DATA SUMMARY SHEET

N/S: Sepulveda Blvd W/E: Lincoln Blvd I/S No: 108
AM/PM: MD Comments: No Project
COUNT DATE: STUDY DATE: GROWTH FACTOR:

Volume/Lane/Signal Configurations table with columns for Northbound, Southbound, Westbound, Eastbound and rows for Existing, Ambient, Related, Project, Total, Lane, Phasing, RTOR, Signal.

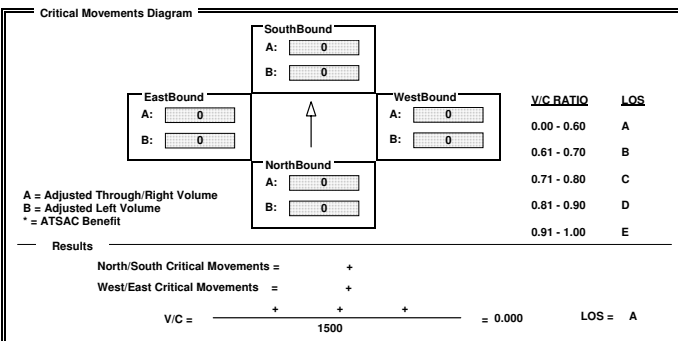

INTERSECTION DATA SUMMARY SHEET

N/S: Lincoln Blvd W/E: Venice Blvd I/S No: 109
AM/PM: MD Comments: No Project
COUNT DATE: STUDY DATE: GROWTH FACTOR:

Volume/Lane/Signal Configurations table with columns for Northbound, Southbound, Westbound, Eastbound and rows for Existing, Ambient, Related, Project, Total, Lane, Phasing, RTOR, Signal.

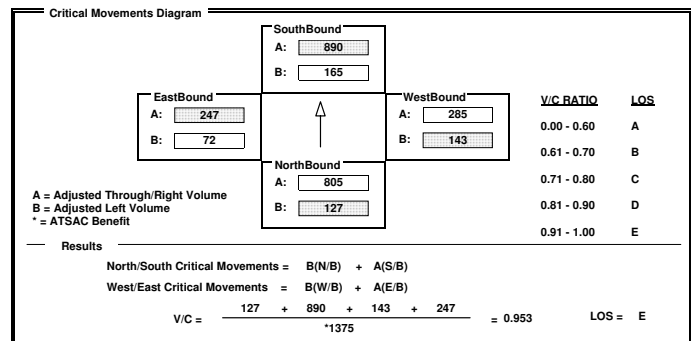

INTERSECTION DATA SUMMARY SHEET

N/S: Lincoln Blvd W/E: Washington Blvd I/S No: 110
 AM/PM: MD Comments: No Project
 COUNT DATE: STUDY DATE: GROWTH FACTOR:

	NORTHBOUND			SOUTHBOUND			WESTBOUND			EASTBOUND		
	LT	TH	RT	LT	TH	RT	LT	TH	RT	LT	TH	RT
EXISTING	330	1570	390	330	1540	170	330	740	390	170	640	950
AMBIENT												
RELATED												
PROJECT												
TOTAL	330	1570	390	330	1540	170	330	740	390	170	640	950
LANE	2	2	1	2	2	1	2	2	1	2	2	1
SIGNAL	Prot-Fix		Auto	Prot-Fix		Auto	Prot-Fix		OLA	Prot-Fix		OLA

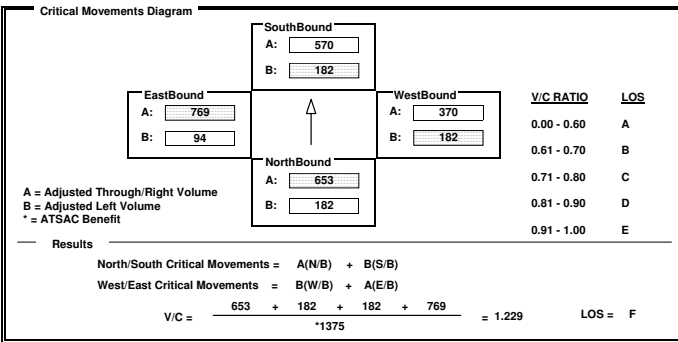

INTERSECTION DATA SUMMARY SHEET

N/S: Lincoln Blvd W/E: 83rd St I/S No: 111
 AM/PM: MD Comments: No Project
 COUNT DATE: STUDY DATE: GROWTH FACTOR:

	NORTHBOUND			SOUTHBOUND			WESTBOUND			EASTBOUND		
	LT	TH	RT	LT	TH	RT	LT	TH	RT	LT	TH	RT
EXISTING	40	1230	30	160	1300	140	50	60	150	30	70	130
AMBIENT												
RELATED												
PROJECT												
TOTAL	40	1230	30	160	1300	140	50	60	150	30	70	130
LANE	1	2	1	1	1	1	1	1	1	2	1	1
SIGNAL	Perm		Auto	Prot-Fix		Auto	Perm		OLA	Prot-Fix		Auto

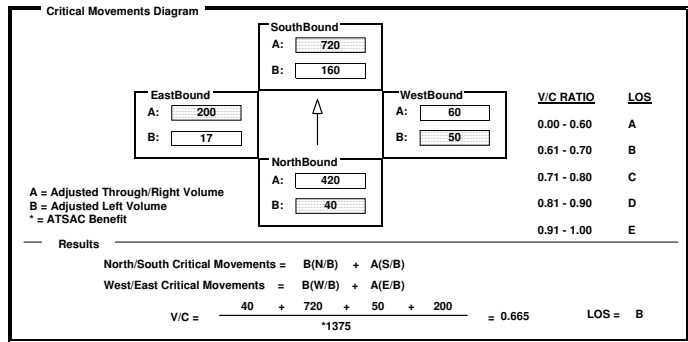

INTERSECTION DATA SUMMARY SHEET

N/S: Sepulveda Blvd W/E: Manchester Ave I/S No: 114
 AM/PM: MD Comments: No Project
 COUNT DATE: STUDY DATE: GROWTH FACTOR:

	NORTHBOUND			SOUTHBOUND			WESTBOUND			EASTBOUND		
	LT	TH	RT	LT	TH	RT	LT	TH	RT	LT	TH	RT
EXISTING	160	990	150	230	990	230	290	630	200	290	750	150
AMBIENT												
RELATED												
PROJECT												
TOTAL	160	990	150	230	990	230	290	630	200	290	750	150
LANE	1	3	1	1	3	1	1	2	1	2	2	1
SIGNAL	Prot-Fix		Auto	Prot-Fix		Auto	Prot-Fix		Auto	Prot-Fix		Auto

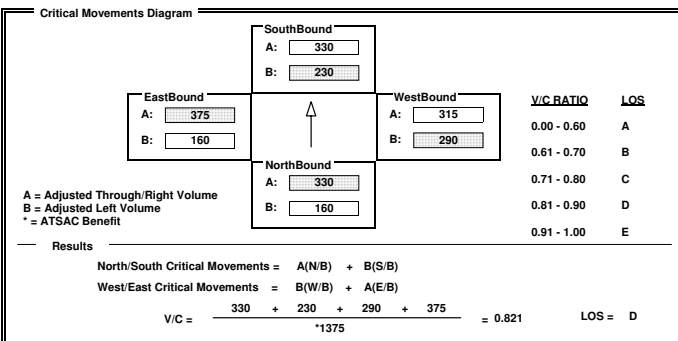

INTERSECTION DATA SUMMARY SHEET

N/S: Sepulveda Blvd W/E: Westchester Pkwy I/S No: 135
 AM/PM: MD Comments: No Project
 COUNT DATE: STUDY DATE: GROWTH FACTOR:

	NORTHBOUND			SOUTHBOUND			WESTBOUND			EASTBOUND		
	LT	TH	RT	LT	TH	RT	LT	TH	RT	LT	TH	RT
EXISTING	210	1320	90	80	1230	70	220	320	130	60	190	120
AMBIENT												
RELATED												
PROJECT												
TOTAL	210	1320	90	80	1230	70	220	320	130	60	190	120
LANE	1	3	1	1	3	1	1	1	1	1	2	1
SIGNAL	Prot-Fix		OLA	Prot-Fix		OLA	Prot-Fix		Auto	Prot-Fix		Auto

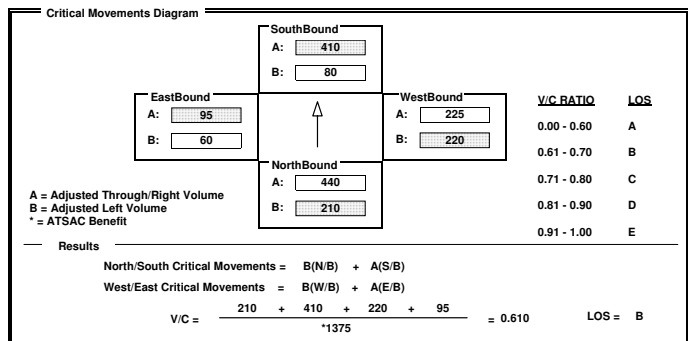

INTERSECTION DATA SUMMARY SHEET

N/S: Sepulveda Blvd W/E: 76th St/77th St I/S No: 136
AM/PM: MD Comments: No Project
COUNT DATE: STUDY DATE: GROWTH FACTOR:

Volume/Lane/Signal Configurations table with columns for Northbound, Southbound, Westbound, Eastbound and rows for Existing, Ambient, Related, Project, Total, Lane, and Signal.

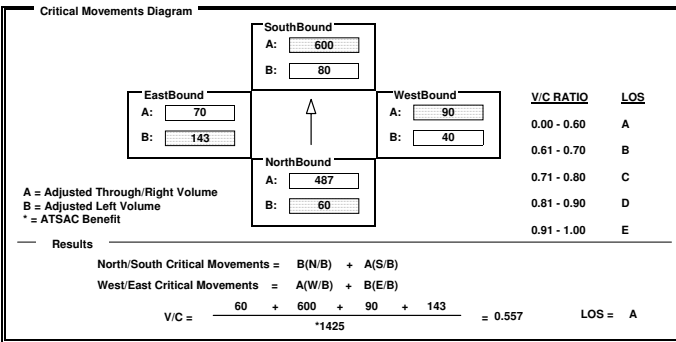

INTERSECTION DATA SUMMARY SHEET

N/S: Sepulveda Blvd W/E: 79 St/80th St I/S No: 137
AM/PM: MD Comments: No Project
COUNT DATE: STUDY DATE: GROWTH FACTOR:

Volume/Lane/Signal Configurations table with columns for Northbound, Southbound, Westbound, Eastbound and rows for Existing, Ambient, Related, Project, Total, Lane, and Signal.

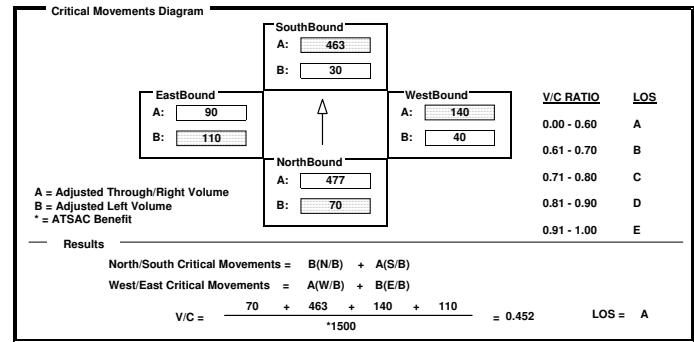

INTERSECTION DATA SUMMARY SHEET

N/S: Sepulveda Blvd W/E: 83rd St I/S No: 138
AM/PM: MD Comments: No Project
COUNT DATE: STUDY DATE: GROWTH FACTOR:

Volume/Lane/Signal Configurations table with columns for Northbound, Southbound, Westbound, Eastbound and rows for Existing, Ambient, Related, Project, Total, Lane, and Signal.

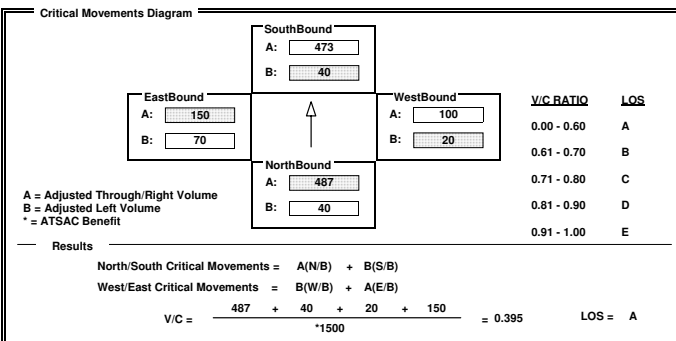

INTERSECTION DATA SUMMARY SHEET

N/S: Sepulveda Blvd W/E: I-105 WB Ramp I/S No: 139
AM/PM: MD Comments: No Project
COUNT DATE: STUDY DATE: GROWTH FACTOR:

Volume/Lane/Signal Configurations table with columns for Northbound, Southbound, Westbound, Eastbound and rows for Existing, Ambient, Related, Project, Total, Lane, and Signal.

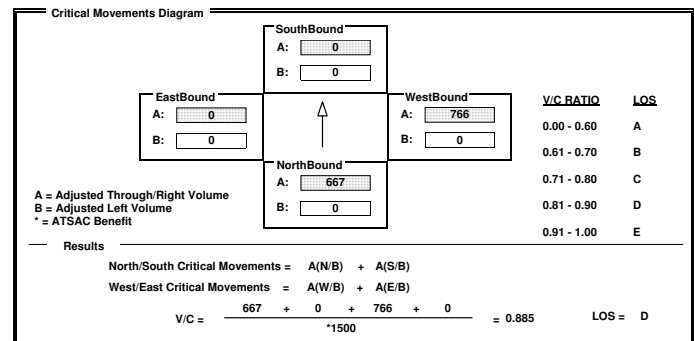

INTERSECTION DATA SUMMARY SHEET

N/S: W/E: I/S No:

AM/PM: Comments:

COUNT DATE: STUDY DATE: GROWTH FACTOR:

	NORTHBOUND			SOUTHBOUND			WESTBOUND			EASTBOUND		
	LT	TH	RT	LT	TH	RT	LT	TH	RT	LT	TH	RT
EXISTING	210	950	50	90	630	240	30	40	120	160	40	110
AMBIENT												
RELATED												
PROJECT												
TOTAL	210	950	50	90	630	240	30	40	120	160	40	110
LANE												
SIGNAL	Phasing Prot-Fix		RTOR Auto	Phasing Perm		RTOR Free	Phasing Perm		RTOR Auto	Phasing Prot-Fix		RTOR Auto

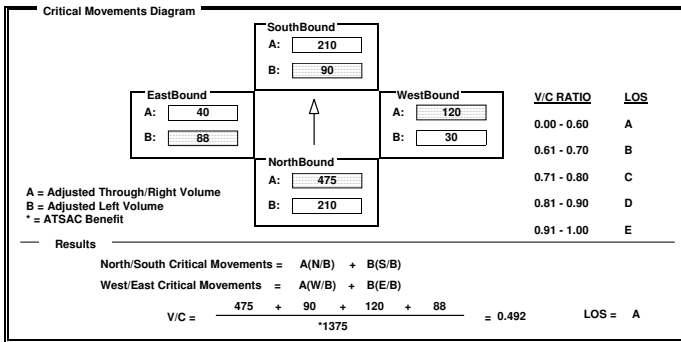

INTERSECTION DATA SUMMARY SHEET

N/S: W/E: I/S No:

AM/PM: Comments:

COUNT DATE: STUDY DATE: GROWTH FACTOR:

	NORTHBOUND			SOUTHBOUND			WESTBOUND			EASTBOUND		
	LT	TH	RT	LT	TH	RT	LT	TH	RT	LT	TH	RT
EXISTING	90	1010	70	90	620	100	50	50	110	190	80	100
AMBIENT												
RELATED												
PROJECT												
TOTAL	90	1010	70	90	620	100	50	50	110	190	80	100
LANE												
SIGNAL	Phasing Perm		RTOR Auto	Phasing Perm		RTOR Auto	Phasing Perm		RTOR Auto	Phasing Perm		RTOR Auto

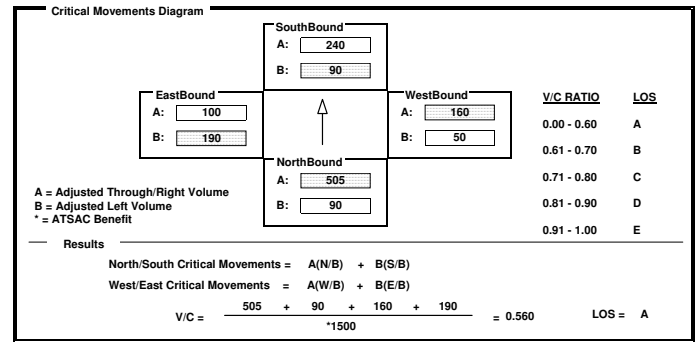

INTERSECTION DATA SUMMARY SHEET

N/S: W/E: I/S No:

AM/PM: Comments:

COUNT DATE: STUDY DATE: GROWTH FACTOR:

	NORTHBOUND			SOUTHBOUND			WESTBOUND			EASTBOUND		
	LT	TH	RT	LT	TH	RT	LT	TH	RT	LT	TH	RT
EXISTING	30	200	150	310	20	110	20	490	190	70	240	10
AMBIENT												
RELATED												
PROJECT												
TOTAL	30	200	150	310	20	110	20	490	190	70	240	10
LANE												
SIGNAL	Phasing Perm		RTOR Auto	Phasing Perm		RTOR Auto	Phasing Perm		RTOR Auto	Phasing Perm		RTOR Auto

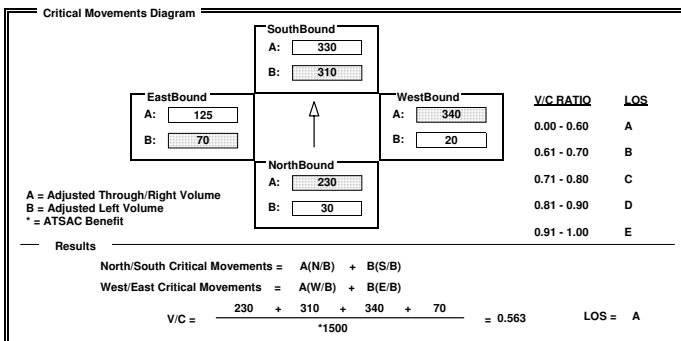

INTERSECTION DATA SUMMARY SHEET

N/S: W/E: I/S No:

AM/PM: Comments:

COUNT DATE: STUDY DATE: GROWTH FACTOR:

	NORTHBOUND			SOUTHBOUND			WESTBOUND			EASTBOUND		
	LT	TH	RT	LT	TH	RT	LT	TH	RT	LT	TH	RT
EXISTING	0	510	150	150	660	0	950	0	80	0	0	0
AMBIENT												
RELATED												
PROJECT												
TOTAL	0	510	150	150	660	0	950	0	80	0	0	0
LANE												
SIGNAL	Phasing Perm		RTOR OLA	Phasing Prot-Fix		RTOR Auto	Phasing Split		RTOR OLA	Phasing Split		RTOR Auto

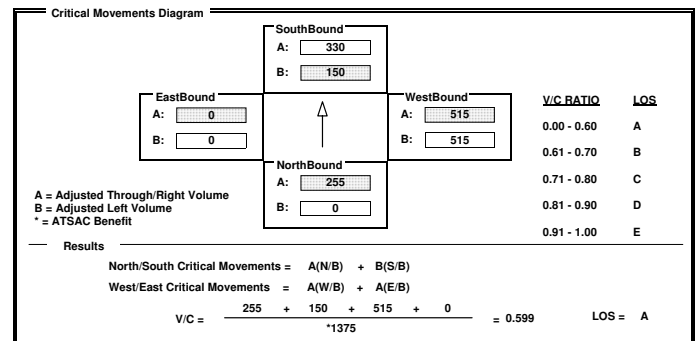

INTERSECTION DATA SUMMARY SHEET

N/S: W/E: I/S No:

AM/PM: Comments:

COUNT DATE: STUDY DATE: GROWTH FACTOR:

	NORTHBOUND			SOUTHBOUND			WESTBOUND			EASTBOUND		
	LT	TH	RT	LT	TH	RT	LT	TH	RT	LT	TH	RT
EXISTING	0	570	150	670	570	0	0	0	250	0	0	0
AMBIENT												
RELATED												
PROJECT												
TOTAL	0	570	150	670	570	0	0	0	250	0	0	0
LANE												
SIGNAL	Phasing		RTOR	Phasing		RTOR	Phasing		RTOR	Phasing		RTOR
	Perm		Auto	Prot-Fix		Auto	Split		OLA	Split		Auto

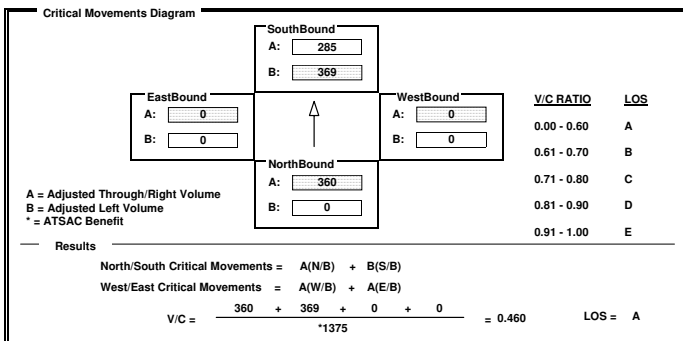

INTERSECTION DATA SUMMARY SHEET

N/S: W/E: I/S No:

AM/PM: Comments:

COUNT DATE: STUDY DATE: GROWTH FACTOR:

	NORTHBOUND			SOUTHBOUND			WESTBOUND			EASTBOUND		
	LT	TH	RT	LT	TH	RT	LT	TH	RT	LT	TH	RT
EXISTING	160	1940	130	140	1380	320	150	680	140	10	680	190
AMBIENT												
RELATED												
PROJECT												
TOTAL	160	1940	130	140	1380	320	150	680	140	10	680	190
LANE												
SIGNAL	Phasing		RTOR	Phasing		RTOR	Phasing		RTOR	Phasing		RTOR
	Prot-Fix		Auto	Prot-Fix		Auto	Prot-Fix		Auto	Perm		Auto

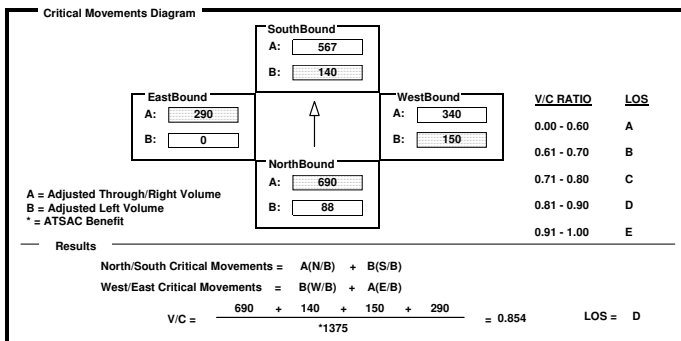

INTERSECTION DATA SUMMARY SHEET

N/S: W/E: I/S No:

AM/PM: Comments:

COUNT DATE: STUDY DATE: GROWTH FACTOR:

	NORTHBOUND			SOUTHBOUND			WESTBOUND			EASTBOUND		
	LT	TH	RT	LT	TH	RT	LT	TH	RT	LT	TH	RT
EXISTING	60	1060	190	130	880	130	230	1090	120	150	930	120
AMBIENT												
RELATED												
PROJECT												
TOTAL	60	1060	190	130	880	130	230	1090	120	150	930	120
LANE												
SIGNAL	Phasing		RTOR	Phasing		RTOR	Phasing		RTOR	Phasing		RTOR
	Perm		Auto	Prot-Fix		Auto	Prot-Fix		Auto	Prot-Fix		Auto

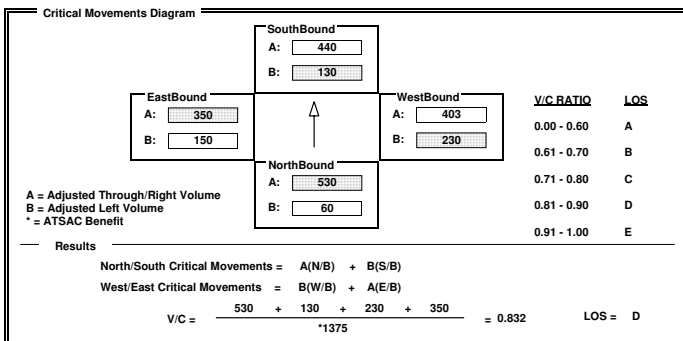

INTERSECTION DATA SUMMARY SHEET

N/S: W/E: I/S No:

AM/PM: Comments:

COUNT DATE: STUDY DATE: GROWTH FACTOR:

	NORTHBOUND			SOUTHBOUND			WESTBOUND			EASTBOUND		
	LT	TH	RT	LT	TH	RT	LT	TH	RT	LT	TH	RT
EXISTING	110	480	40	230	640	130	40	880	140	240	670	100
AMBIENT												
RELATED												
PROJECT												
TOTAL	110	480	40	230	640	130	40	880	140	240	670	100
LANE												
SIGNAL	Phasing		RTOR	Phasing		RTOR	Phasing		RTOR	Phasing		RTOR
	Prot-Fix		Auto	Prot-Fix		Auto	Prot-Fix		Auto	Prot-Fix		Auto

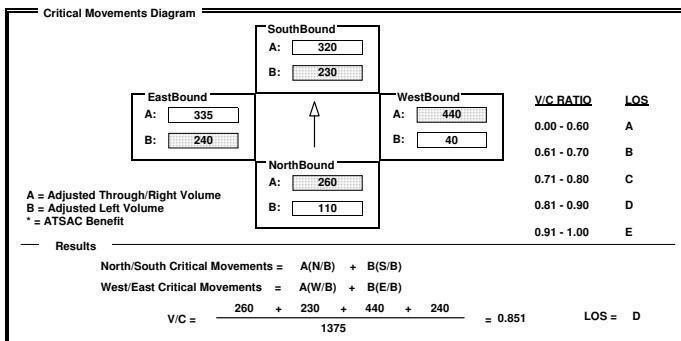

INTERSECTION DATA SUMMARY SHEET

N/S: W/E: I/S No:

AM/PM: Comments:

COUNT DATE: STUDY DATE: GROWTH FACTOR:

	NORTHBOUND			SOUTHBOUND			WESTBOUND			EASTBOUND		
	LT	TH	RT	LT	TH	RT	LT	TH	RT	LT	TH	RT
EXISTING	0	1820	680	130	0	0	680	0	60	0	0	0
AMBIENT												
RELATED												
PROJECT												
TOTAL	0	1820	680	130	0	0	680	0	60	0	0	0
LANE												
SIGNAL	Phasing: Prot-Fix RTOR: Auto		Phasing: Prot-Fix RTOR: Auto		Phasing: Split RTOR: Free		Phasing: RTOR: Free		Phasing: RTOR: Free		Phasing: RTOR: Free	

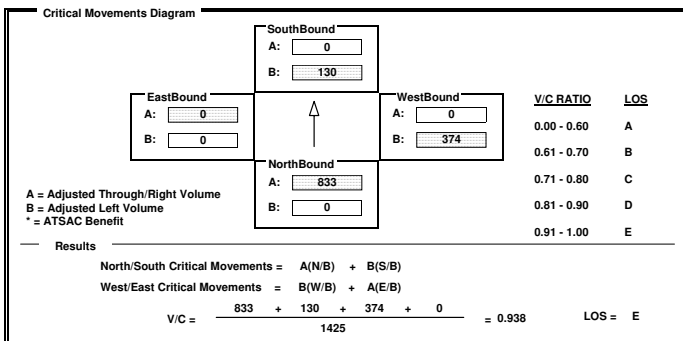

INTERSECTION DATA SUMMARY SHEET

N/S: W/E: I/S No:

AM/PM: Comments:

COUNT DATE: STUDY DATE: GROWTH FACTOR:

	NORTHBOUND			SOUTHBOUND			WESTBOUND			EASTBOUND		
	LT	TH	RT	LT	TH	RT	LT	TH	RT	LT	TH	RT
EXISTING	140	780	160	90	560	210	220	1400	190	170	1170	80
AMBIENT												
RELATED												
PROJECT												
TOTAL	140	780	160	90	560	210	220	1400	190	170	1170	80
LANE												
SIGNAL	Phasing: Prot-Fix RTOR: OLA		Phasing: Prot-Fix RTOR: OLA		Phasing: Prot-Fix RTOR: Auto		Phasing: Prot-Fix RTOR: Auto		Phasing: Prot-Fix RTOR: Auto		Phasing: Prot-Fix RTOR: Auto	

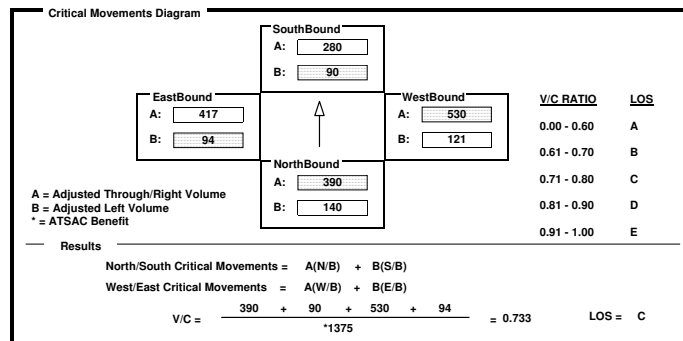

INTERSECTION DATA SUMMARY SHEET

N/S: W/E: I/S No:

AM/PM: Comments:

COUNT DATE: STUDY DATE: GROWTH FACTOR:

	NORTHBOUND			SOUTHBOUND			WESTBOUND			EASTBOUND		
	LT	TH	RT	LT	TH	RT	LT	TH	RT	LT	TH	RT
EXISTING	130	1430	40	90	1360	210	100	240	110	280	260	190
AMBIENT												
RELATED												
PROJECT												
TOTAL	130	1430	40	90	1360	210	100	240	110	280	260	190
LANE												
SIGNAL	Phasing: Perm RTOR: Auto		Phasing: Perm RTOR: Auto		Phasing: Perm RTOR: Auto		Phasing: Perm RTOR: Auto		Phasing: Perm RTOR: Auto		Phasing: Perm RTOR: Auto	

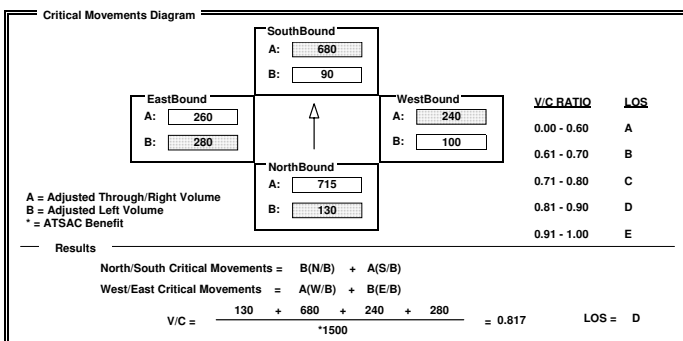

INTERSECTION DATA SUMMARY SHEET

N/S: W/E: I/S No:

AM/PM: Comments:

COUNT DATE: STUDY DATE: GROWTH FACTOR:

	NORTHBOUND			SOUTHBOUND			WESTBOUND			EASTBOUND		
	LT	TH	RT	LT	TH	RT	LT	TH	RT	LT	TH	RT
EXISTING	100	570	130	80	490	110	100	770	110	150	800	110
AMBIENT												
RELATED												
PROJECT												
TOTAL	100	570	130	80	490	110	100	770	110	150	800	110
LANE												
SIGNAL	Phasing: Prot-Fix RTOR: OLA		Phasing: Prot-Fix RTOR: Auto		Phasing: Prot-Fix RTOR: Auto		Phasing: Prot-Fix RTOR: Auto		Phasing: Prot-Fix RTOR: Auto		Phasing: Prot-Fix RTOR: Auto	

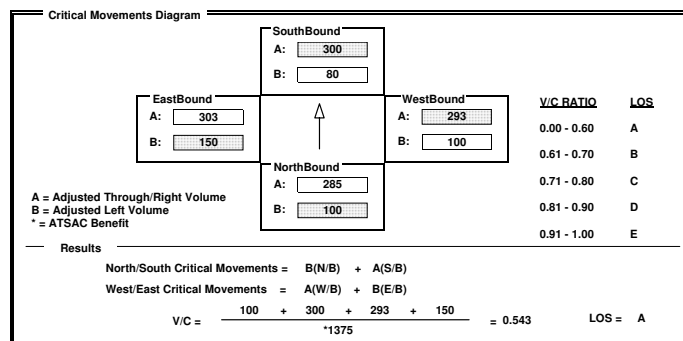

INTERSECTION DATA SUMMARY SHEET

N/S: W/E: I/S No:

AM/PM: Comments:

COUNT DATE: STUDY DATE: GROWTH FACTOR:

	NORTHBOUND			SOUTHBOUND			WESTBOUND			EASTBOUND		
	LT	TH	RT	LT	TH	RT	LT	TH	RT	LT	TH	RT
EXISTING	0	0	0	0	0	0	0	0	0	0	0	0
AMBIENT												
RELATED												
PROJECT												
TOTAL	0	0	0	0	0	0	0	0	0	0	0	0
LANE	1	2	1	1	3	1	2	2	1	2	1	1
SIGNAL	Phasing: Perm	RTOR: Auto		Phasing: Perm	RTOR: OLA		Phasing: Prot-Fix	RTOR: Auto		Phasing: Prot-Fix	RTOR: Auto	

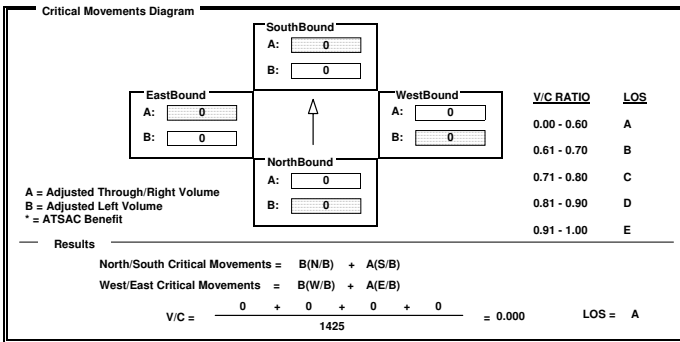

INTERSECTION DATA SUMMARY SHEET

N/S: W/E: I/S No:

AM/PM: Comments:

COUNT DATE: STUDY DATE: GROWTH FACTOR:

	NORTHBOUND			SOUTHBOUND			WESTBOUND			EASTBOUND		
	LT	TH	RT	LT	TH	RT	LT	TH	RT	LT	TH	RT
EXISTING	200	1050	210	290	630	100	210	440	240	140	620	150
AMBIENT												
RELATED												
PROJECT												
TOTAL	200	1050	210	290	630	100	210	440	240	140	620	150
LANE	1	2	1	1	3	1	1	1	1	1	2	1
SIGNAL	Phasing: Prot-Fix	RTOR: Auto		Phasing: Prot-Fix	RTOR: Auto		Phasing: Prot-Fix	RTOR: Auto		Phasing: Prot-Fix	RTOR: Auto	

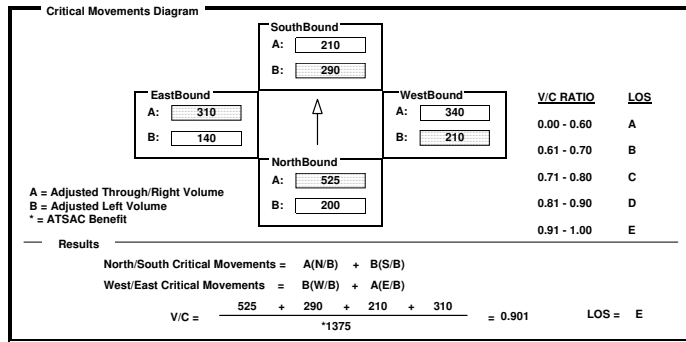

INTERSECTION DATA SUMMARY SHEET

N/S: W/E: I/S No:

AM/PM: Comments:

COUNT DATE: STUDY DATE: GROWTH FACTOR:

	NORTHBOUND			SOUTHBOUND			WESTBOUND			EASTBOUND		
	LT	TH	RT	LT	TH	RT	LT	TH	RT	LT	TH	RT
EXISTING	20	50	40	610	20	590	40	1510	360	730	1640	20
AMBIENT												
RELATED												
PROJECT												
TOTAL	20	50	40	610	20	590	40	1510	360	730	1640	20
LANE	1	2	1	2	1	1	1	4	1	2	4	1
SIGNAL	Phasing: Split	RTOR: Auto		Phasing: Split	RTOR: Auto		Phasing: Prot-Fix	RTOR: OLA		Phasing: Prot-Fix	RTOR: Auto	

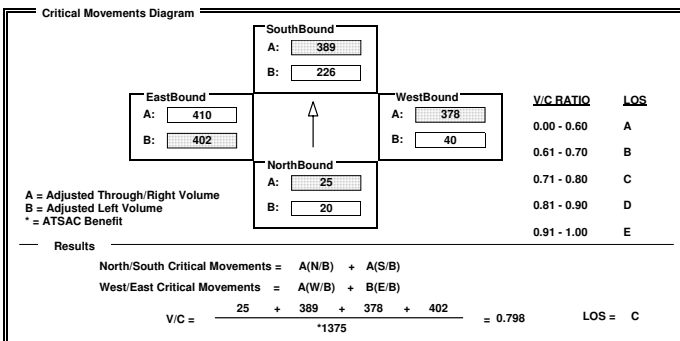

INTERSECTION DATA SUMMARY SHEET

N/S: W/E: I/S No:

AM/PM: Comments:

COUNT DATE: STUDY DATE: GROWTH FACTOR:

	NORTHBOUND			SOUTHBOUND			WESTBOUND			EASTBOUND		
	LT	TH	RT	LT	TH	RT	LT	TH	RT	LT	TH	RT
EXISTING	40	110	1040	50	120	10	520	970	30	30	720	120
AMBIENT												
RELATED												
PROJECT												
TOTAL	40	110	1040	50	120	10	520	970	30	30	720	120
LANE	1	2	1	1	1	1	2	1	1	1	2	1
SIGNAL	Phasing: Split	RTOR: OLA		Phasing: Split	RTOR: Auto		Phasing: Prot-Fix	RTOR: Auto		Phasing: Prot-Fix	RTOR: Auto	

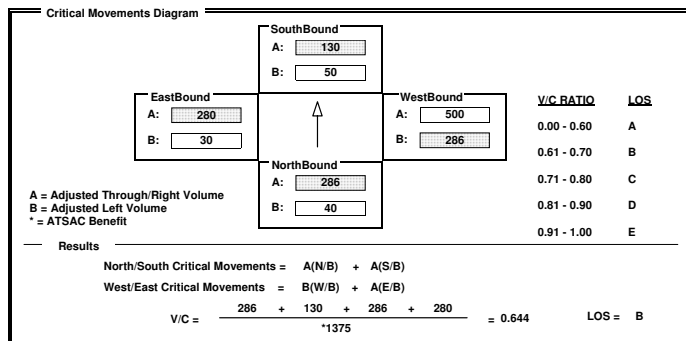

INTERSECTION DATA SUMMARY SHEET

N/S: W/E: I/S No:

AM/PM: PM Comments:

COUNT DATE: STUDY DATE: GROWTH FACTOR:

	NORTHBOUND			SOUTHBOUND			WESTBOUND			EASTBOUND		
	LT	TH	RT	LT	TH	RT	LT	TH	RT	LT	TH	RT
EXISTING	190	860	320	400	330	130	210	850	180	120	1290	370
AMBIENT												
RELATED												
PROJECT												
TOTAL	190	860	320	400	330	130	210	850	180	120	1290	370
LANE	1	2	1	1	1	1	1	2	1	1	2	1
SIGNAL	Prot-Fix	Auto	Prot-Fix	Auto	Prot-Fix	Auto	Prot-Fix	Auto	Prot-Fix	Auto	Prot-Fix	Auto

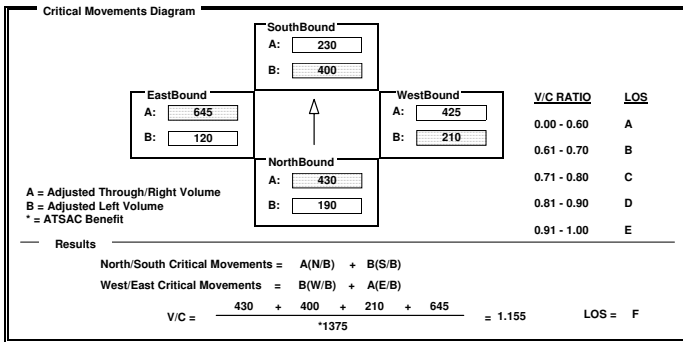

INTERSECTION DATA SUMMARY SHEET

N/S: W/E: I/S No:

AM/PM: PM Comments:

COUNT DATE: STUDY DATE: GROWTH FACTOR:

	NORTHBOUND			SOUTHBOUND			WESTBOUND			EASTBOUND		
	LT	TH	RT	LT	TH	RT	LT	TH	RT	LT	TH	RT
EXISTING	250	640	130	110	440	100	100	510	60	150	1190	320
AMBIENT												
RELATED												
PROJECT												
TOTAL	250	640	130	110	440	100	100	510	60	150	1190	320
LANE	1	2	1	1	1	1	1	1	1	1	1	1
SIGNAL	Perm	Auto	Perm	Auto	Perm	Auto	Perm	Auto	Perm	Auto	Perm	Auto

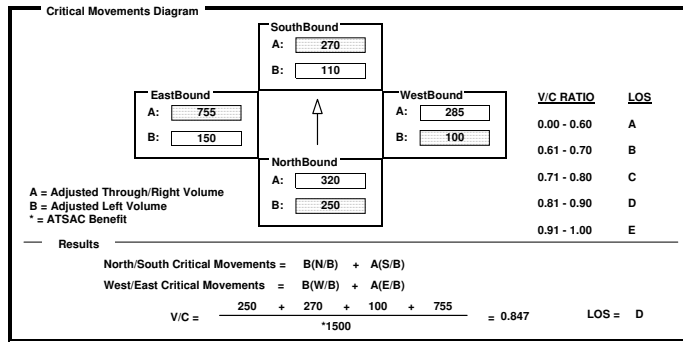

INTERSECTION DATA SUMMARY SHEET

N/S: W/E: I/S No:

AM/PM: PM Comments:

COUNT DATE: STUDY DATE: GROWTH FACTOR:

	NORTHBOUND			SOUTHBOUND			WESTBOUND			EASTBOUND		
	LT	TH	RT	LT	TH	RT	LT	TH	RT	LT	TH	RT
EXISTING	500	660	90	130	530	180	110	1360	120	210	1850	440
AMBIENT												
RELATED												
PROJECT												
TOTAL	500	660	90	130	530	180	110	1360	120	210	1850	440
LANE	2	1	1	2	2	1	1	3	1	1	3	1
SIGNAL	Prot-Fix	Auto	Prot-Fix	OLA	Prot-Fix	Auto	Prot-Fix	Auto	Prot-Fix	Auto	Prot-Fix	Auto

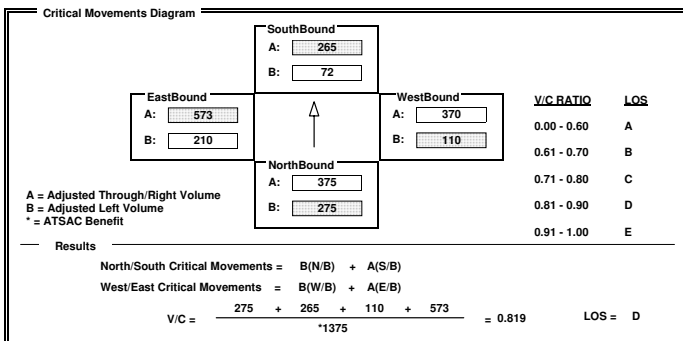

INTERSECTION DATA SUMMARY SHEET

N/S: W/E: I/S No:

AM/PM: PM Comments:

COUNT DATE: STUDY DATE: GROWTH FACTOR:

	NORTHBOUND			SOUTHBOUND			WESTBOUND			EASTBOUND		
	LT	TH	RT	LT	TH	RT	LT	TH	RT	LT	TH	RT
EXISTING	210	580	610	410	750	110	410	420	330	230	1090	360
AMBIENT												
RELATED												
PROJECT												
TOTAL	210	580	610	410	750	110	410	420	330	230	1090	360
LANE	2	2	1	2	2	1	2	3	1	2	2	1
SIGNAL	Prot-Fix	OLA	Prot-Fix	OLA	Prot-Fix	OLA	Prot-Fix	OLA	Prot-Fix	Auto	Prot-Fix	Auto

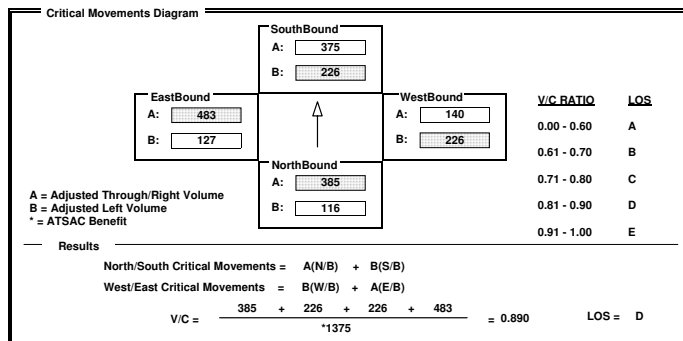

INTERSECTION DATA SUMMARY SHEET

N/S: Lincoln Blvd W/E: Bali Way I/S No: 21
 AM/PM: PM Comments: No Project
 COUNT DATE: STUDY DATE: GROWTH FACTOR:

	NORTHBOUND			SOUTHBOUND			WESTBOUND			EASTBOUND		
	LT	TH	RT	LT	TH	RT	LT	TH	RT	LT	TH	RT
EXISTING	350	1430	30	60	1490	360	10	10	30	350	10	130
AMBIENT												
RELATED												
PROJECT												
TOTAL	350	1430	30	60	1490	360	10	10	30	350	10	130
LANE	1 2 1			1 2 1			1			1 1 1		
SIGNAL	Prot-Fix		Auto	Prot-Fix		Auto	Prot-Fix		Auto	Prot-Fix		Auto

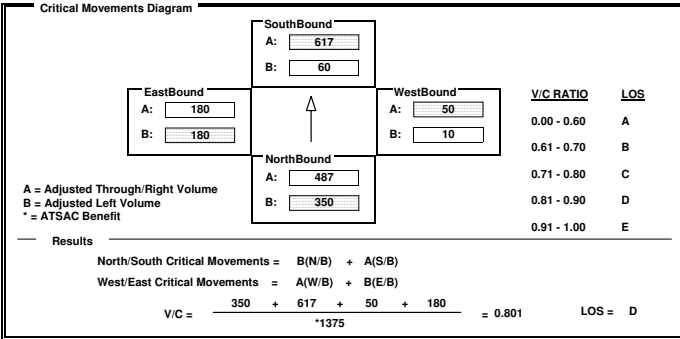

INTERSECTION DATA SUMMARY SHEET

N/S: Lincoln Blvd W/E: Bluff Creek Dr I/S No: 22
 AM/PM: PM Comments: No Project
 COUNT DATE: STUDY DATE: GROWTH FACTOR:

	NORTHBOUND			SOUTHBOUND			WESTBOUND			EASTBOUND		
	LT	TH	RT	LT	TH	RT	LT	TH	RT	LT	TH	RT
EXISTING	0	2120	240	190	2190	0	360	0	100	0	0	0
AMBIENT												
RELATED												
PROJECT												
TOTAL	0	2120	240	190	2190	0	360	0	100	0	0	0
LANE	4 1 1			2 4 1			1 1 1			1 1 1		
SIGNAL	Perm		Auto	Prot-Fix		Auto	Split		Auto	Split		Auto

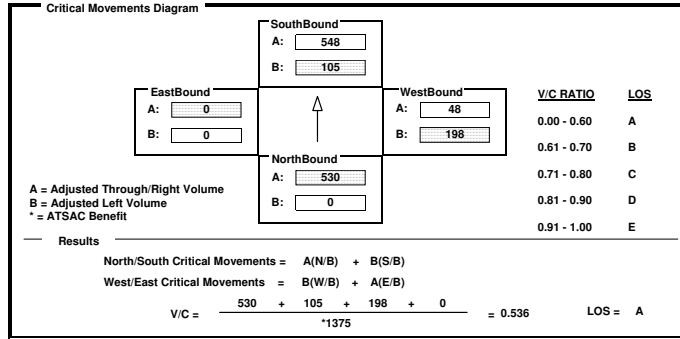

INTERSECTION DATA SUMMARY SHEET

N/S: La Tijera Blvd W/E: Centinela Ave I/S No: 27
 AM/PM: PM Comments: No Project
 COUNT DATE: STUDY DATE: GROWTH FACTOR:

	NORTHBOUND			SOUTHBOUND			WESTBOUND			EASTBOUND		
	LT	TH	RT	LT	TH	RT	LT	TH	RT	LT	TH	RT
EXISTING	190	1080	310	140	1050	130	160	720	20	140	700	50
AMBIENT												
RELATED												
PROJECT												
TOTAL	190	1080	310	140	1050	130	160	720	20	140	700	50
LANE	2 2 1			1 2 1			1 2 1			1 2 1		
SIGNAL	Prot-Fix		Auto	Prot-Fix		Auto	Prot-Fix		Auto	Prot-Fix		Auto

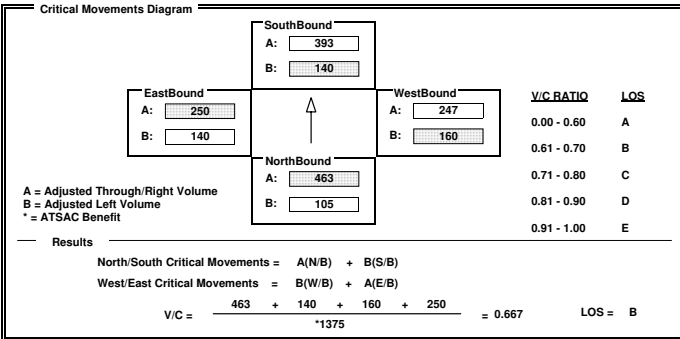

INTERSECTION DATA SUMMARY SHEET

N/S: La Cienega Blvd W/E: Century Blvd I/S No: 36
 AM/PM: PM Comments: No Project
 COUNT DATE: STUDY DATE: GROWTH FACTOR:

	NORTHBOUND			SOUTHBOUND			WESTBOUND			EASTBOUND		
	LT	TH	RT	LT	TH	RT	LT	TH	RT	LT	TH	RT
EXISTING	190	380	630	580	560	500	120	820	240	180	1270	870
AMBIENT												
RELATED												
PROJECT												
TOTAL	190	380	630	580	560	500	120	820	240	180	1270	870
LANE	1 2 2			1 2 2			1 3 1			1 3 1		
SIGNAL	Prot-Fix		OLA	Prot-Fix		OLA	Prot-Fix		Auto	Prot-Fix		OLA

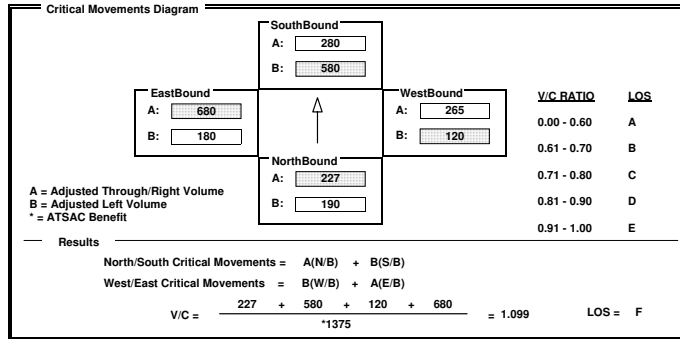

INTERSECTION DATA SUMMARY SHEET

N/S: W/E: I/S No:
 AM/PM: Comments:
 COUNT DATE: STUDY DATE: GROWTH FACTOR:

	NORTHBOUND			SOUTHBOUND			WESTBOUND			EASTBOUND		
	LT	TH	RT	LT	TH	RT	LT	TH	RT	LT	TH	RT
EXISTING	0	3460	20	0	2230	250	560	100	320	0	0	0
AMBIENT												
RELATED												
PROJECT												
TOTAL	0	3460	20	0	2230	250	560	100	320	0	0	0
LANE												
SIGNAL	Phasing		RTOR	Phasing		RTOR	Phasing		RTOR	Phasing		RTOR
	Perm		Free	Perm		Auto	Split		Auto	<none>		Auto

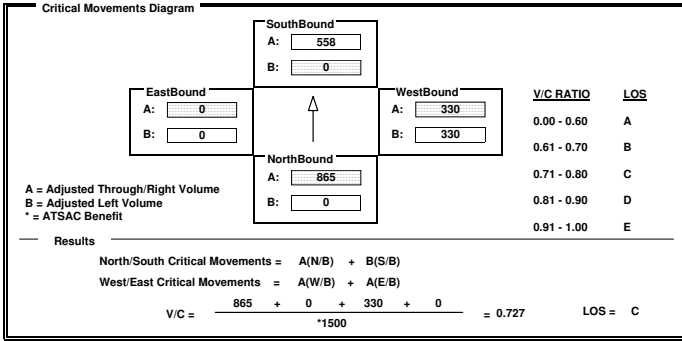

INTERSECTION DATA SUMMARY SHEET

N/S: W/E: I/S No:
 AM/PM: Comments:
 COUNT DATE: STUDY DATE: GROWTH FACTOR:

	NORTHBOUND			SOUTHBOUND			WESTBOUND			EASTBOUND		
	LT	TH	RT	LT	TH	RT	LT	TH	RT	LT	TH	RT
EXISTING	170	20	450	80	20	60	40	660	40	40	1160	50
AMBIENT												
RELATED												
PROJECT												
TOTAL	170	20	450	80	20	60	40	660	40	40	1160	50
LANE												
SIGNAL	Phasing		RTOR	Phasing		RTOR	Phasing		RTOR	Phasing		RTOR
	Split		OLA	Split		Auto	Prot-Fix		Auto	Prot-Fix		Auto

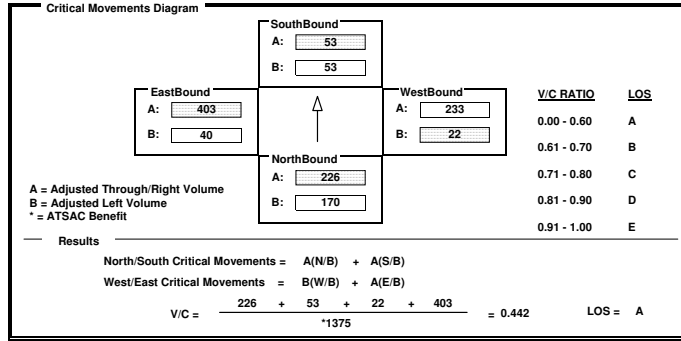

INTERSECTION DATA SUMMARY SHEET

N/S: W/E: I/S No:
 AM/PM: Comments:
 COUNT DATE: STUDY DATE: GROWTH FACTOR:

	NORTHBOUND			SOUTHBOUND			WESTBOUND			EASTBOUND		
	LT	TH	RT	LT	TH	RT	LT	TH	RT	LT	TH	RT
EXISTING	1000	1930	30	80	1630	120	50	20	40	140	30	1050
AMBIENT												
RELATED												
PROJECT												
TOTAL	1000	1930	30	80	1630	120	50	20	40	140	30	1050
LANE												
SIGNAL	Phasing		RTOR	Phasing		RTOR	Phasing		RTOR	Phasing		RTOR
	Prot-Fix		Auto	Prot-Fix		Auto	Perm		Auto	Perm		Free

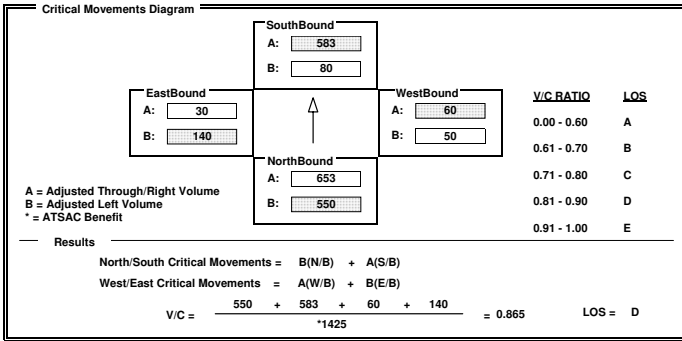

INTERSECTION DATA SUMMARY SHEET

N/S: W/E: I/S No:
 AM/PM: Comments:
 COUNT DATE: STUDY DATE: GROWTH FACTOR:

	NORTHBOUND			SOUTHBOUND			WESTBOUND			EASTBOUND		
	LT	TH	RT	LT	TH	RT	LT	TH	RT	LT	TH	RT
EXISTING	0	1740	590	750	1910	0	620	0	350	0	0	0
AMBIENT												
RELATED												
PROJECT												
TOTAL	0	1740	590	750	1910	0	620	0	350	0	0	0
LANE												
SIGNAL	Phasing		RTOR	Phasing		RTOR	Phasing		RTOR	Phasing		RTOR
	<none>		Free	Prot-Fix		Auto	Split		Auto	<none>		<none>

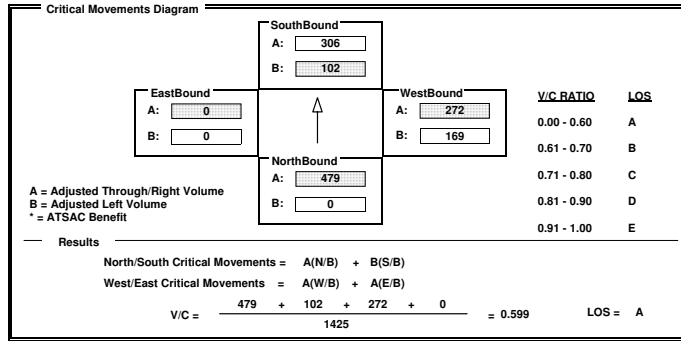

INTERSECTION DATA SUMMARY SHEET

N/S: La Cienega Blvd W/E: Imperial Hwy I/S No: 67
 AM/PM: PM Comments: No Project
 COUNT DATE: STUDY DATE: GROWTH FACTOR:

Volume/Lane/Signal Configurations

	NORTHBOUND			SOUTHBOUND			WESTBOUND			EASTBOUND		
	LT	TH	RT	LT	TH	RT	LT	TH	RT	LT	TH	RT
EXISTING	70	240	640	510	470	480	100	410	220	240	1220	250
AMBIENT												
RELATED												
PROJECT												
TOTAL	70	240	640	510	470	480	100	410	220	240	1220	250
LANE	[Diagram]			[Diagram]			[Diagram]			[Diagram]		
SIGNAL	Phasing: Prot-Fix RTOR: Auto		Phasing: Prot-Fix RTOR: Auto		Phasing: Prot-Fix RTOR: OLA		Phasing: Prot-Fix RTOR: OLA		Phasing: Prot-Fix RTOR: OLA		Phasing: Prot-Fix RTOR: Auto	

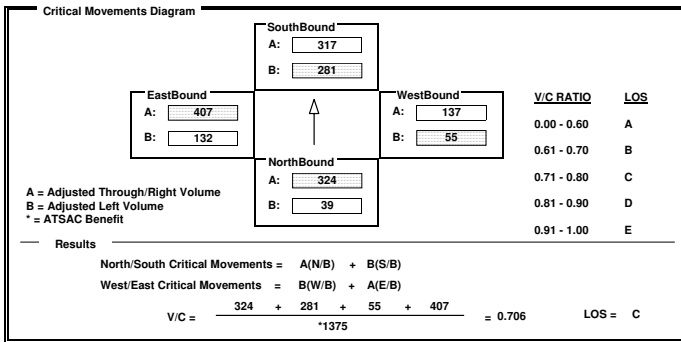

INTERSECTION DATA SUMMARY SHEET

N/S: Sepulveda Blvd W/E: Imperial Hwy I/S No: 71
 AM/PM: PM Comments: No Project
 COUNT DATE: STUDY DATE: GROWTH FACTOR:

Volume/Lane/Signal Configurations

	NORTHBOUND			SOUTHBOUND			WESTBOUND			EASTBOUND		
	LT	TH	RT	LT	TH	RT	LT	TH	RT	LT	TH	RT
EXISTING	180	1590	1210	420	2380	230	250	390	390	200	330	170
AMBIENT												
RELATED												
PROJECT												
TOTAL	180	1590	1210	420	2380	230	250	390	390	200	330	170
LANE	[Diagram]			[Diagram]			[Diagram]			[Diagram]		
SIGNAL	Phasing: Prot-Fix RTOR: Auto		Phasing: Prot-Fix RTOR: Auto		Phasing: Prot-Fix RTOR: OLA		Phasing: Prot-Fix RTOR: OLA		Phasing: Prot-Fix RTOR: Auto		Phasing: Prot-Fix RTOR: Auto	

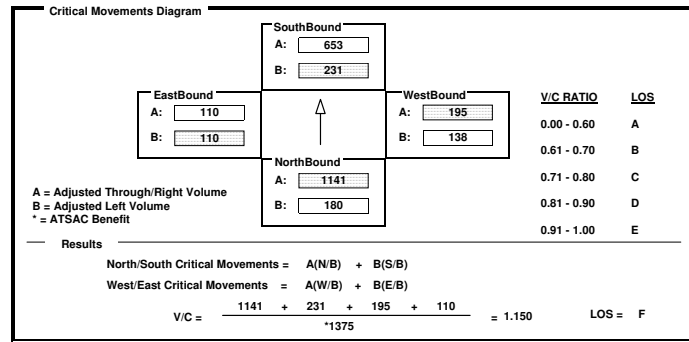

INTERSECTION DATA SUMMARY SHEET

N/S: 105 WB Off Ramps/Nash St W/E: Imperial Hwy I/S No: 73
 AM/PM: PM Comments: No Project
 COUNT DATE: STUDY DATE: GROWTH FACTOR:

Volume/Lane/Signal Configurations

	NORTHBOUND			SOUTHBOUND			WESTBOUND			EASTBOUND		
	LT	TH	RT	LT	TH	RT	LT	TH	RT	LT	TH	RT
EXISTING	80	0	130	200	230	200	70	980	0	0	860	60
AMBIENT												
RELATED												
PROJECT												
TOTAL	80	0	130	200	230	200	70	980	0	0	860	60
LANE	[Diagram]			[Diagram]			[Diagram]			[Diagram]		
SIGNAL	Phasing: Split RTOR: Auto		Phasing: Split RTOR: Auto		Phasing: Prot-Fix RTOR: Auto		Phasing: Prot-Fix RTOR: Auto		Phasing: Perm RTOR: Auto		Phasing: Perm RTOR: Auto	

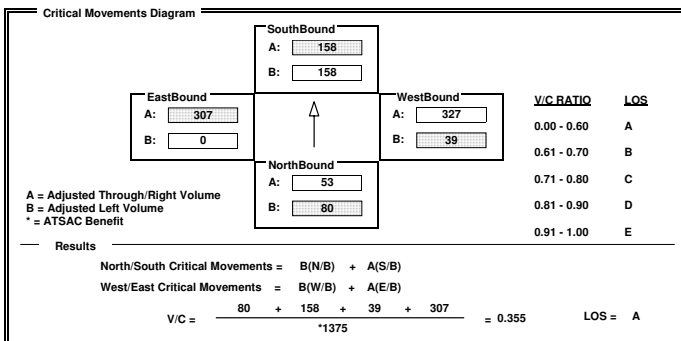

INTERSECTION DATA SUMMARY SHEET

N/S: 105 EB On Ramps W/E: Imperial Hwy I/S No: 74
 AM/PM: PM Comments: No Project
 COUNT DATE: STUDY DATE: GROWTH FACTOR:

Volume/Lane/Signal Configurations

	NORTHBOUND			SOUTHBOUND			WESTBOUND			EASTBOUND		
	LT	TH	RT	LT	TH	RT	LT	TH	RT	LT	TH	RT
EXISTING	510	0	520	0	0	0	400	650	0	0	1160	790
AMBIENT												
RELATED												
PROJECT												
TOTAL	510	0	520	0	0	0	400	650	0	0	1160	790
LANE	[Diagram]			[Diagram]			[Diagram]			[Diagram]		
SIGNAL	Phasing: Split RTOR: OLA		Phasing: <none> RTOR: <none>		Phasing: Prot-Fix RTOR: Auto		Phasing: Prot-Fix RTOR: Auto		Phasing: Perm RTOR: OLA		Phasing: Perm RTOR: OLA	

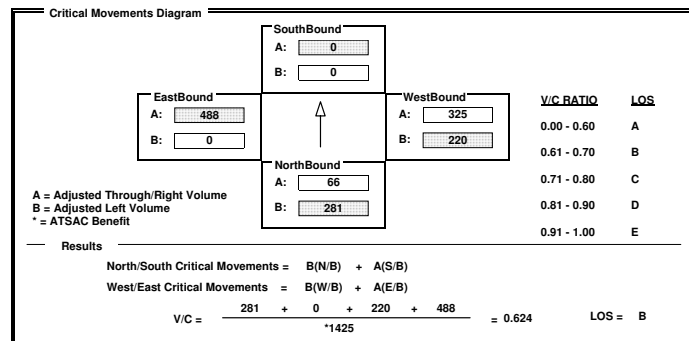

INTERSECTION DATA SUMMARY SHEET

N/S: Lincoln Blvd W/E: Jefferson Blvd I/S No: 78
 AM/PM: PM Comments: No Project
 COUNT DATE: STUDY DATE: GROWTH FACTOR:

	NORTHBOUND			SOUTHBOUND			WESTBOUND			EASTBOUND		
	LT	TH	RT	LT	TH	RT	LT	TH	RT	LT	TH	RT
EXISTING	50	1730	440	480	1650	600	680	440	1310	90	190	50
AMBIENT												
RELATED												
PROJECT												
TOTAL	50	1730	440	480	1650	600	680	440	1310	90	190	50
LANE	1	4	1	2	3	1	2	2	2	1	2	1
SIGNAL	Prot-Fix	OLA	Prot-Fix	OLA	Prot-Fix	OLA	Prot-Fix	OLA	Prot-Fix	Auto	OLA	Auto

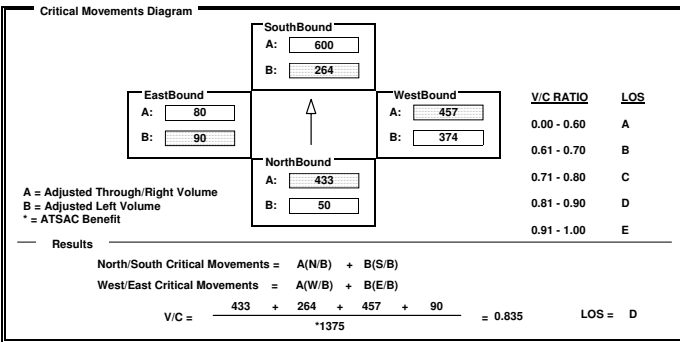

INTERSECTION DATA SUMMARY SHEET

N/S: La Cienega Blvd W/E: La Tijera Blvd I/S No: 88
 AM/PM: PM Comments: No Project
 COUNT DATE: STUDY DATE: GROWTH FACTOR:

	NORTHBOUND			SOUTHBOUND			WESTBOUND			EASTBOUND		
	LT	TH	RT	LT	TH	RT	LT	TH	RT	LT	TH	RT
EXISTING	0	2280	210	0	2710	1320	0	0	0	1070	260	20
AMBIENT												
RELATED												
PROJECT												
TOTAL	0	2280	210	0	2710	1320	0	0	0	1070	260	20
LANE		2	1		3	1				3	1	1
SIGNAL	Perm	Auto	Perm	OLA	<none>	<none>	Perm	Auto	Perm	OLA	Split	Auto

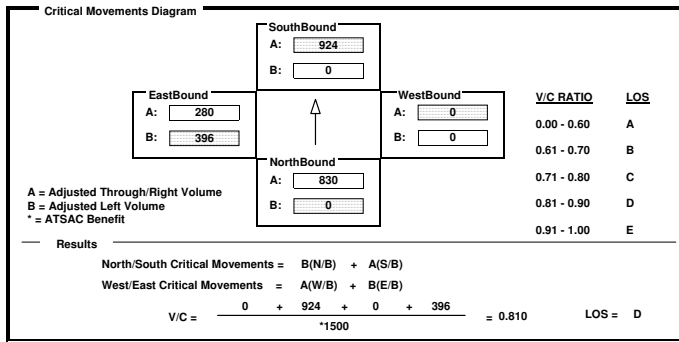

INTERSECTION DATA SUMMARY SHEET

N/S: Lincoln Blvd W/E: La Tijera Blvd I/S No: 99
 AM/PM: PM Comments: No Project
 COUNT DATE: STUDY DATE: GROWTH FACTOR:

	NORTHBOUND			SOUTHBOUND			WESTBOUND			EASTBOUND		
	LT	TH	RT	LT	TH	RT	LT	TH	RT	LT	TH	RT
EXISTING	40	1670	20	40	1640	140	20	10	10	30	20	60
AMBIENT												
RELATED												
PROJECT												
TOTAL	40	1670	20	40	1640	140	20	10	10	30	20	60
LANE	2	2	1	1	2	1				1	1	1
SIGNAL	Prot-Fix	Auto	Prot-Fix	Auto	Perm	Auto	Perm	Auto	Perm	OLA	OLA	OLA

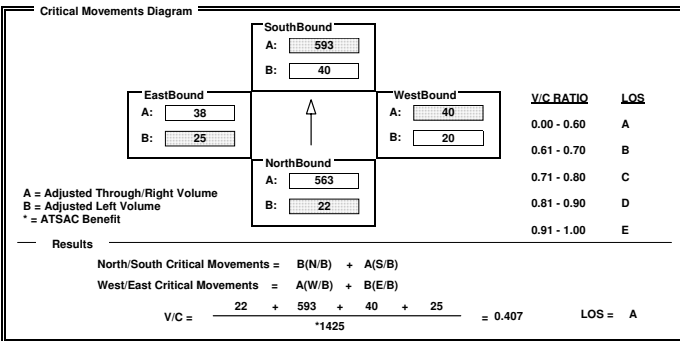

INTERSECTION DATA SUMMARY SHEET

N/S: La Tijera W/E: Manchester Ave I/S No: 100
 AM/PM: PM Comments: No Project
 COUNT DATE: STUDY DATE: GROWTH FACTOR:

	NORTHBOUND			SOUTHBOUND			WESTBOUND			EASTBOUND		
	LT	TH	RT	LT	TH	RT	LT	TH	RT	LT	TH	RT
EXISTING	160	240	410	180	470	330	290	750	170	350	1070	180
AMBIENT												
RELATED												
PROJECT												
TOTAL	160	240	410	180	470	330	290	750	170	350	1070	180
LANE	1	2	1	1	2	1	1	2	1	1	2	1
SIGNAL	Prot-Fix	Auto	Prot-Fix	Auto	Prot-Fix	Auto	Prot-Fix	Auto	Prot-Fix	Auto	Prot-Fix	Free

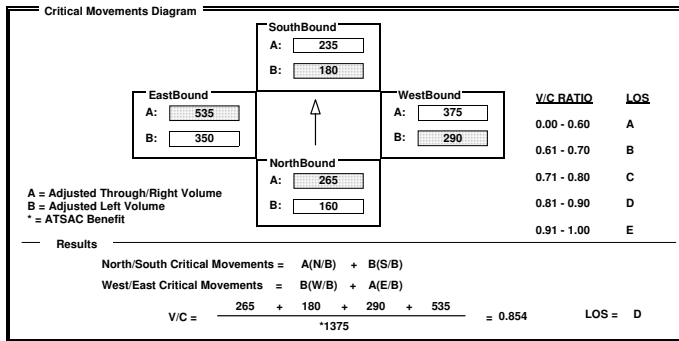

INTERSECTION DATA SUMMARY SHEET

N/S: Sepulveda Blvd W/E: La Tijera Blvd I/S No: 101
AM/PM: PM Comments: No Project
COUNT DATE: STUDY DATE: GROWTH FACTOR:

Volume/Lane/Signal Configurations table with columns for Northbound, Southbound, Westbound, Eastbound and rows for Existing, Ambient, Related, Project, Total, Lane, and Signal.

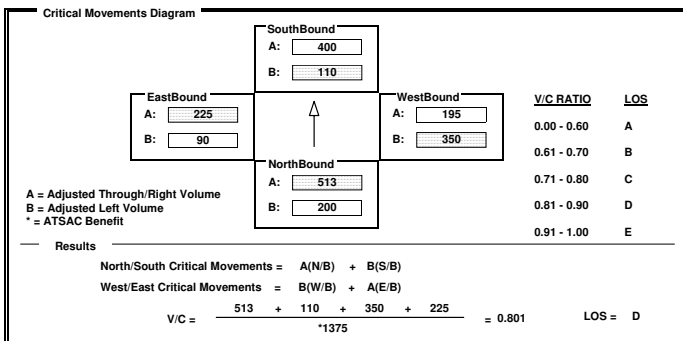

INTERSECTION DATA SUMMARY SHEET

N/S: 405 NB Ramps W/E: La Tijera Blvd I/S No: 102
AM/PM: PM Comments: No Project
COUNT DATE: STUDY DATE: GROWTH FACTOR:

Volume/Lane/Signal Configurations table with columns for Northbound, Southbound, Westbound, Eastbound and rows for Existing, Ambient, Related, Project, Total, Lane, and Signal.

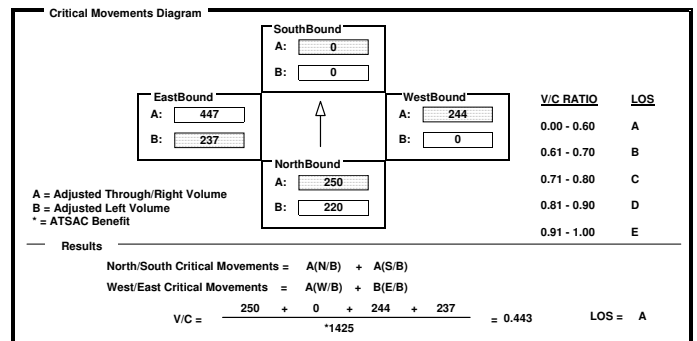

INTERSECTION DATA SUMMARY SHEET

N/S: La Tijera Blvd W/E: 405 SB Ramps I/S No: 103
AM/PM: PM Comments: No Project
COUNT DATE: STUDY DATE: GROWTH FACTOR:

Volume/Lane/Signal Configurations table with columns for Northbound, Southbound, Westbound, Eastbound and rows for Existing, Ambient, Related, Project, Total, Lane, and Signal.

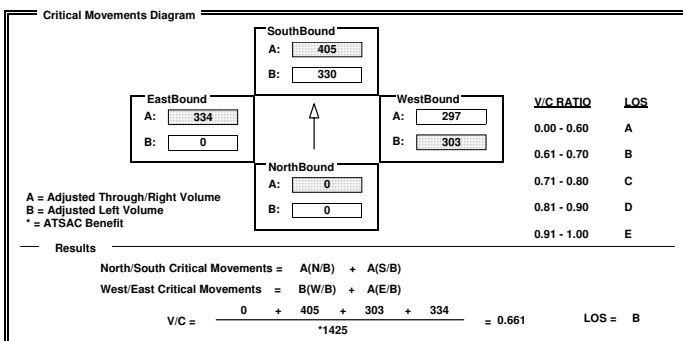

INTERSECTION DATA SUMMARY SHEET

N/S: Lincoln Blvd W/E: LMU Dr I/S No: 104
AM/PM: PM Comments: No Project
COUNT DATE: STUDY DATE: GROWTH FACTOR:

Volume/Lane/Signal Configurations table with columns for Northbound, Southbound, Westbound, Eastbound and rows for Existing, Ambient, Related, Project, Total, Lane, and Signal.

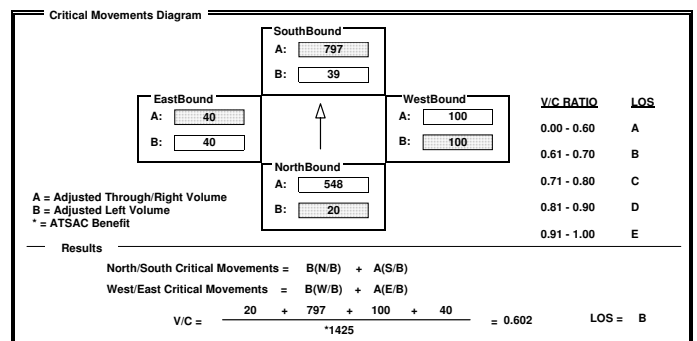

INTERSECTION DATA SUMMARY SHEET

N/S: Lincoln Blvd W/E: Manchester Blvd I/S No: 105
 AM/PM: PM Comments: No Project
 COUNT DATE: STUDY DATE: GROWTH FACTOR:

	NORTHBOUND			SOUTHBOUND			WESTBOUND			EASTBOUND		
	LT	TH	RT	LT	TH	RT	LT	TH	RT	LT	TH	RT
EXISTING	90	1590	240	260	1490	210	180	330	240	100	260	90
AMBIENT												
RELATED												
PROJECT												
TOTAL	90	1590	240	260	1490	210	180	330	240	100	260	90
LANE	1	3	1	1	2	1	2	2	1	2	2	1
SIGNAL	Prot-Fix	Auto	Prot-Fix	Auto	Prot-Fix	OLA	Prot-Fix	OLA				

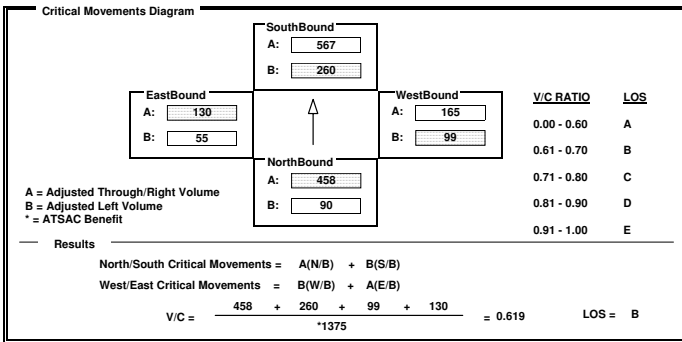

INTERSECTION DATA SUMMARY SHEET

N/S: Lincoln Blvd W/E: Marina Pointe Dr/ Maxella Ave I/S No: 106
 AM/PM: PM Comments: No Project
 COUNT DATE: STUDY DATE: GROWTH FACTOR:

	NORTHBOUND			SOUTHBOUND			WESTBOUND			EASTBOUND		
	LT	TH	RT	LT	TH	RT	LT	TH	RT	LT	TH	RT
EXISTING	350	2100	250	230	2270	70	220	100	260	70	60	70
AMBIENT												
RELATED												
PROJECT												
TOTAL	350	2100	250	230	2270	70	220	100	260	70	60	70
LANE	2	3	1	2	3	1	1	1	1	1	1	1
SIGNAL	Prot-Fix	OLA	Prot-Fix	Auto	Perm	OLA	Prot-Fix	OLA	Perm	OLA		

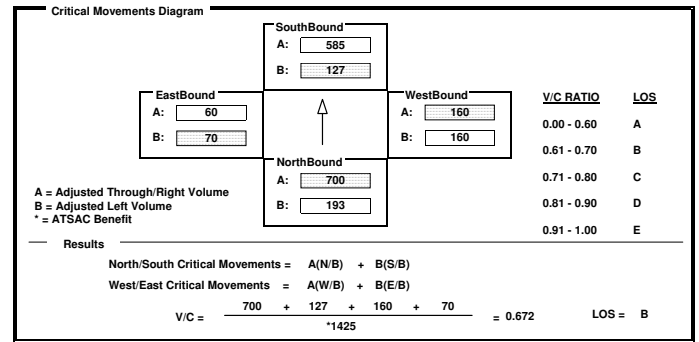

INTERSECTION DATA SUMMARY SHEET

N/S: Lincoln Blvd W/E: Mindanao Way I/S No: 107
 AM/PM: PM Comments: No Project
 COUNT DATE: STUDY DATE: GROWTH FACTOR:

	NORTHBOUND			SOUTHBOUND			WESTBOUND			EASTBOUND		
	LT	TH	RT	LT	TH	RT	LT	TH	RT	LT	TH	RT
EXISTING	250	1600	300	280	1200	100	350	650	150	20	490	150
AMBIENT												
RELATED												
PROJECT												
TOTAL	250	1600	300	280	1200	100	350	650	150	20	490	150
LANE	1	3	1	1	2	1	2	1	1			
SIGNAL	Prot-Fix	OLA	Prot-Fix	Auto	Prot-Fix	<none>	Prot-Fix	<none>	Perm	Auto		

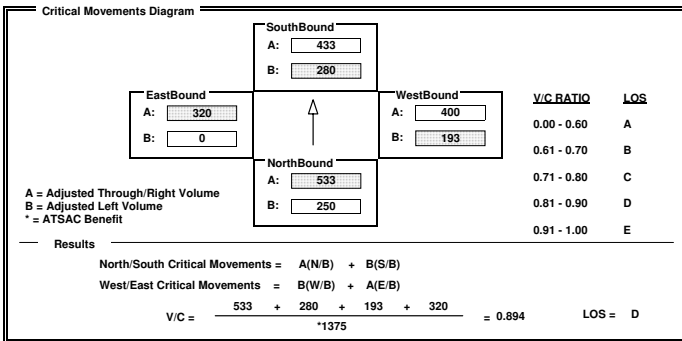

INTERSECTION DATA SUMMARY SHEET

N/S: Sepulveda Blvd W/E: Lincoln Blvd I/S No: 108
 AM/PM: PM Comments: No Project
 COUNT DATE: STUDY DATE: GROWTH FACTOR:

	NORTHBOUND			SOUTHBOUND			WESTBOUND			EASTBOUND		
	LT	TH	RT	LT	TH	RT	LT	TH	RT	LT	TH	RT
EXISTING	1420	1860	390	0	2050	10	0	0	10	0	0	1640
AMBIENT												
RELATED												
PROJECT												
TOTAL	1420	1860	390	0	2050	10	0	0	10	0	0	1640
LANE	4	2	1		3	1			1			4
SIGNAL	Prot-Fix	Auto	<none>	Auto	<none>	Auto	<none>	Auto	<none>	Auto		

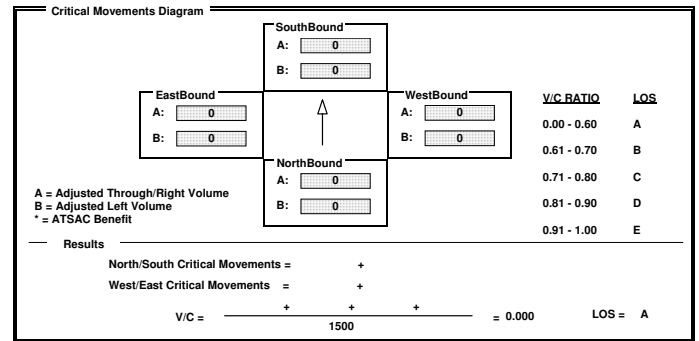

INTERSECTION DATA SUMMARY SHEET

N/S: Lincoln Blvd W/E: Venice Blvd I/S No: 109
AM/PM: PM Comments: No Project
COUNT DATE: STUDY DATE: GROWTH FACTOR:

Volume/Lane/Signal Configurations table with columns for Northbound, Southbound, Westbound, Eastbound and rows for Existing, Ambient, Related, Project, Total, Lane, and Signal.

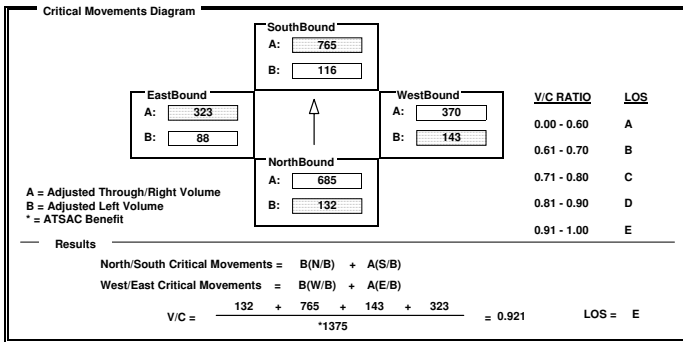

INTERSECTION DATA SUMMARY SHEET

N/S: Lincoln Blvd W/E: Washington Blvd I/S No: 110
AM/PM: PM Comments: No Project
COUNT DATE: STUDY DATE: GROWTH FACTOR:

Volume/Lane/Signal Configurations table with columns for Northbound, Southbound, Westbound, Eastbound and rows for Existing, Ambient, Related, Project, Total, Lane, and Signal.

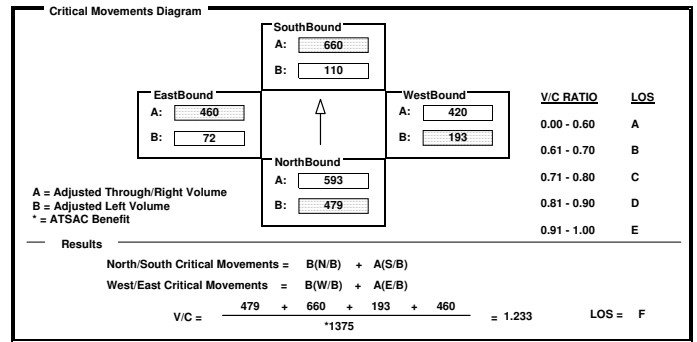

INTERSECTION DATA SUMMARY SHEET

N/S: Lincoln Blvd W/E: 83rd St I/S No: 111
AM/PM: PM Comments: No Project
COUNT DATE: STUDY DATE: GROWTH FACTOR:

Volume/Lane/Signal Configurations table with columns for Northbound, Southbound, Westbound, Eastbound and rows for Existing, Ambient, Related, Project, Total, Lane, and Signal.

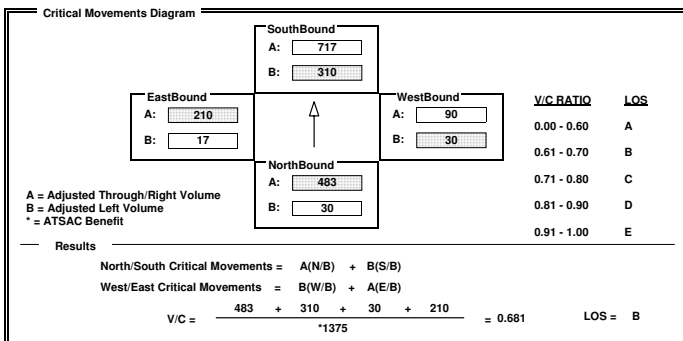

INTERSECTION DATA SUMMARY SHEET

N/S: Sepulveda Blvd W/E: Manchester Ave I/S No: 114
AM/PM: PM Comments: No Project
COUNT DATE: STUDY DATE: GROWTH FACTOR:

Volume/Lane/Signal Configurations table with columns for Northbound, Southbound, Westbound, Eastbound and rows for Existing, Ambient, Related, Project, Total, Lane, and Signal.

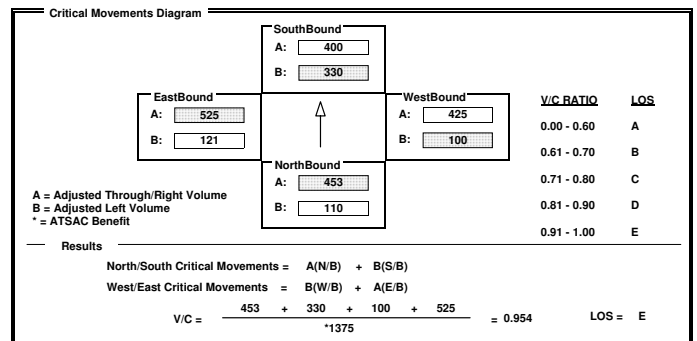

INTERSECTION DATA SUMMARY SHEET

N/S: Sepulveda Blvd W/E: Westchester Pkwy I/S No: 135
 AM/PM: PM Comments: No Project
 COUNT DATE: STUDY DATE: GROWTH FACTOR:

	NORTHBOUND			SOUTHBOUND			WESTBOUND			EASTBOUND		
	LT	TH	RT	LT	TH	RT	LT	TH	RT	LT	TH	RT
EXISTING	220	1570	80	150	1500	60	350	330	130	70	420	150
AMBIENT												
RELATED												
PROJECT												
TOTAL	220	1570	80	150	1500	60	350	330	130	70	420	150
LANE	1 3 1	1 3 1	1 1 1	1 1 1	1 1 1	1 1 1	1 2 1	1 1 1	1 1 1	1 1 1	1 1 1	1 1 1
SIGNAL	Prot-Fix	OLA	Prot-Fix	OLA	Prot-Fix	Auto	Prot-Fix	Auto	Prot-Fix	Auto	Prot-Fix	Auto

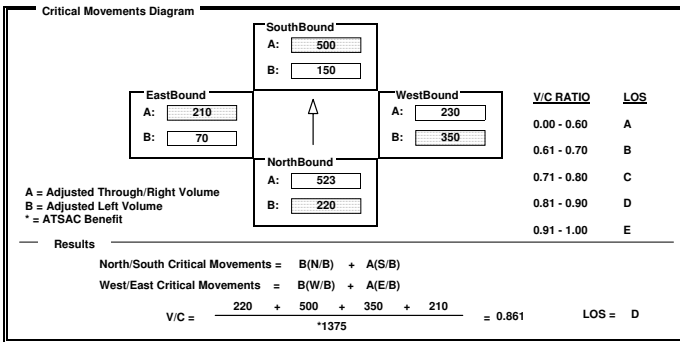

INTERSECTION DATA SUMMARY SHEET

N/S: Sepulveda Blvd W/E: 76th St/77th St I/S No: 136
 AM/PM: PM Comments: No Project
 COUNT DATE: STUDY DATE: GROWTH FACTOR:

	NORTHBOUND			SOUTHBOUND			WESTBOUND			EASTBOUND		
	LT	TH	RT	LT	TH	RT	LT	TH	RT	LT	TH	RT
EXISTING	50	1830	30	130	2000	350	40	120	90	350	90	70
AMBIENT												
RELATED												
PROJECT												
TOTAL	50	1830	30	130	2000	350	40	120	90	350	90	70
LANE	1 3 1	1 3 1	1 1 1	1 2 1	1 0	1 1 1	1 1 1	1 1 1	1 1 1	2 1 1	1 1 1	1 1 1
SIGNAL	Perm	Auto	Perm	Auto	Split	Auto	Split	Auto	Split	Auto	Split	Auto

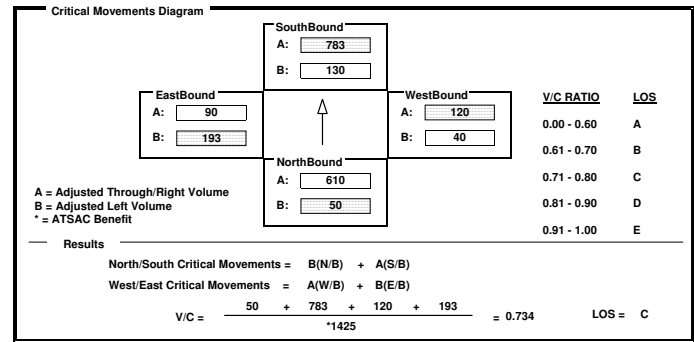

INTERSECTION DATA SUMMARY SHEET

N/S: Sepulveda Blvd W/E: 79 St/80th St I/S No: 137
 AM/PM: PM Comments: No Project
 COUNT DATE: STUDY DATE: GROWTH FACTOR:

	NORTHBOUND			SOUTHBOUND			WESTBOUND			EASTBOUND		
	LT	TH	RT	LT	TH	RT	LT	TH	RT	LT	TH	RT
EXISTING	100	1700	20	130	1700	240	50	80	30	140	90	90
AMBIENT												
RELATED												
PROJECT												
TOTAL	100	1700	20	130	1700	240	50	80	30	140	90	90
LANE	1 2 1	1 3 1	1 1 1	1 1 1	1 1 1	1 1 1	1 1 1	1 1 1	1 1 1	1 1 1	1 1 1	1 1 1
SIGNAL	Perm	Auto	Perm	Auto	Perm	Auto	Perm	Auto	Perm	Auto	Perm	Auto

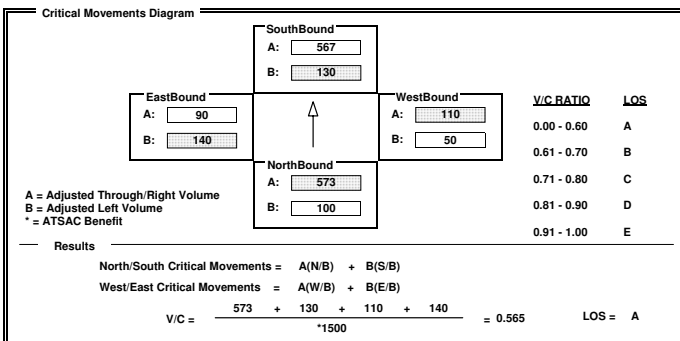

INTERSECTION DATA SUMMARY SHEET

N/S: Sepulveda Blvd W/E: 83rd St I/S No: 138
 AM/PM: PM Comments: No Project
 COUNT DATE: STUDY DATE: GROWTH FACTOR:

	NORTHBOUND			SOUTHBOUND			WESTBOUND			EASTBOUND		
	LT	TH	RT	LT	TH	RT	LT	TH	RT	LT	TH	RT
EXISTING	70	1690	20	60	1730	80	10	60	40	80	140	50
AMBIENT												
RELATED												
PROJECT												
TOTAL	70	1690	20	60	1730	80	10	60	40	80	140	50
LANE	1 2 1	1 3 1	1 1 1	1 2 1	1 1 1	1 1 1	1 1 1	1 1 1	1 1 1	1 1 1	1 1 1	1 1 1
SIGNAL	Perm	Auto	Perm	Auto	Perm	Auto	Perm	Auto	Perm	Auto	Perm	Auto

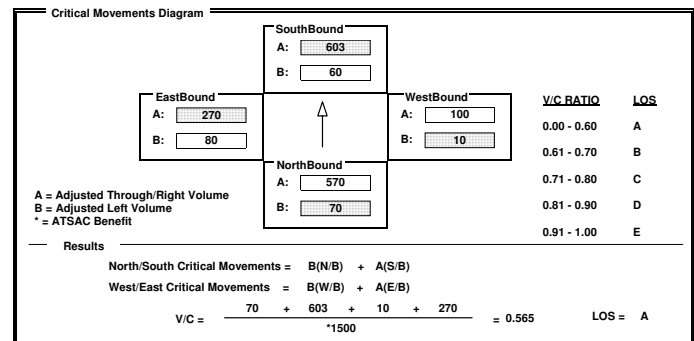

INTERSECTION DATA SUMMARY SHEET

N/S: W/E: I/S No:

AM/PM: **PM** Comments:

COUNT DATE: STUDY DATE: GROWTH FACTOR:

		NORTHBOUND			SOUTHBOUND			WESTBOUND			EASTBOUND		
		LT	TH	RT	LT	TH	RT	LT	TH	RT	LT	TH	RT
EXISTING		0	2180	0	0	0	0	0	0	1800	0	0	0
AMBIENT													
RELATED													
PROJECT													
TOTAL		0	2180	0	0	0	0	0	0	1800	0	0	0
LANE		<input type="checkbox"/> <input checked="" type="checkbox"/> <input type="checkbox"/> <input type="checkbox"/> <input type="checkbox"/>			<input type="checkbox"/> <input type="checkbox"/> <input type="checkbox"/> <input type="checkbox"/> <input type="checkbox"/>			<input type="checkbox"/> <input type="checkbox"/> <input type="checkbox"/> <input type="checkbox"/> <input type="checkbox"/>			<input type="checkbox"/> <input type="checkbox"/> <input type="checkbox"/> <input type="checkbox"/> <input type="checkbox"/>		
SIGNAL		Phasing: <input type="text" value="Split"/> RTOR: <input type="text" value="<none>"/>			Phasing: <input type="text" value="<none>"/> RTOR: <input type="text" value="<none>"/>			Phasing: <input type="text" value="Split"/> RTOR: <input type="text" value="<none>"/>			Phasing: <input type="text" value="<none>"/> RTOR: <input type="text" value="<none>"/>		

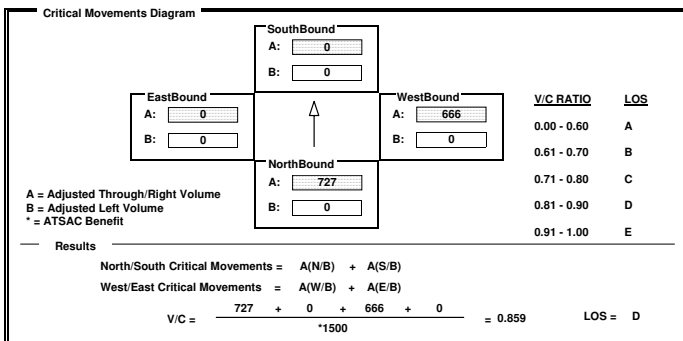

INTERSECTION DATA SUMMARY SHEET

N/S: W/E: I/S No:

AM/PM: **PM** Comments:

COUNT DATE: STUDY DATE: GROWTH FACTOR:

		NORTHBOUND			SOUTHBOUND			WESTBOUND			EASTBOUND		
		LT	TH	RT	LT	TH	RT	LT	TH	RT	LT	TH	RT
EXISTING		120	1270	60	60	950	210	40	30	170	190	30	100
AMBIENT													
RELATED													
PROJECT													
TOTAL		120	1270	60	60	950	210	40	30	170	190	30	100
LANE		<input type="checkbox"/> <input checked="" type="checkbox"/> <input type="checkbox"/> <input type="checkbox"/> <input type="checkbox"/>			<input type="checkbox"/> <input type="checkbox"/> <input checked="" type="checkbox"/> <input type="checkbox"/> <input type="checkbox"/>			<input type="checkbox"/> <input type="checkbox"/> <input type="checkbox"/> <input type="checkbox"/> <input type="checkbox"/>			<input type="checkbox"/> <input type="checkbox"/> <input type="checkbox"/> <input type="checkbox"/> <input type="checkbox"/>		
SIGNAL		Phasing: <input type="text" value="Prot-Fix"/> RTOR: <input type="text" value="Auto"/>			Phasing: <input type="text" value="Perm"/> RTOR: <input type="text" value="Free"/>			Phasing: <input type="text" value="Perm"/> RTOR: <input type="text" value="Auto"/>			Phasing: <input type="text" value="Prot-Fix"/> RTOR: <input type="text" value="Auto"/>		

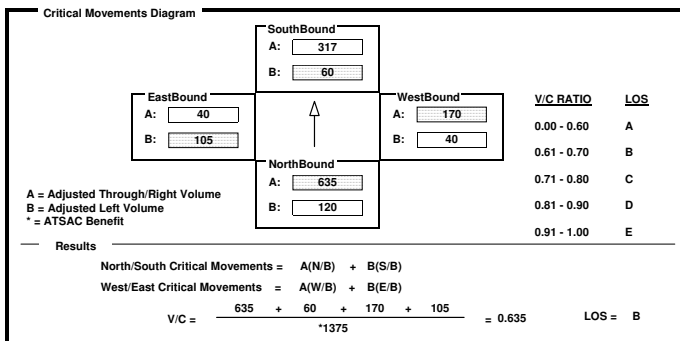

INTERSECTION DATA SUMMARY SHEET

N/S: W/E: I/S No:

AM/PM: **PM** Comments:

COUNT DATE: STUDY DATE: GROWTH FACTOR:

		NORTHBOUND			SOUTHBOUND			WESTBOUND			EASTBOUND		
		LT	TH	RT	LT	TH	RT	LT	TH	RT	LT	TH	RT
EXISTING		100	990	100	50	840	90	100	60	210	250	90	270
AMBIENT													
RELATED													
PROJECT													
TOTAL		100	990	100	50	840	90	100	60	210	250	90	270
LANE		<input type="checkbox"/> <input checked="" type="checkbox"/> <input type="checkbox"/> <input type="checkbox"/> <input type="checkbox"/>			<input type="checkbox"/> <input type="checkbox"/> <input checked="" type="checkbox"/> <input type="checkbox"/> <input type="checkbox"/>			<input type="checkbox"/> <input type="checkbox"/> <input type="checkbox"/> <input type="checkbox"/> <input type="checkbox"/>			<input type="checkbox"/> <input type="checkbox"/> <input type="checkbox"/> <input type="checkbox"/> <input type="checkbox"/>		
SIGNAL		Phasing: <input type="text" value="Perm"/> RTOR: <input type="text" value="Auto"/>			Phasing: <input type="text" value="Perm"/> RTOR: <input type="text" value="Auto"/>			Phasing: <input type="text" value="Perm"/> RTOR: <input type="text" value="Auto"/>			Phasing: <input type="text" value="Perm"/> RTOR: <input type="text" value="Auto"/>		

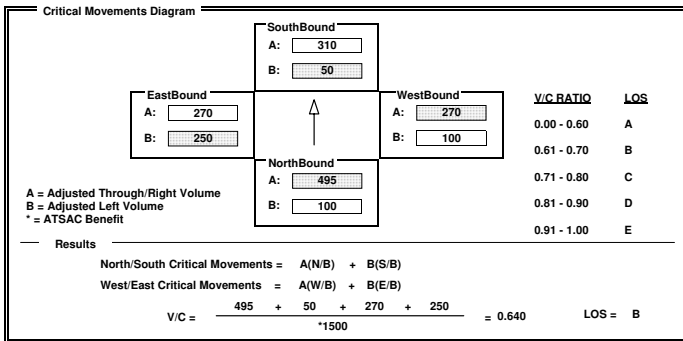

INTERSECTION DATA SUMMARY SHEET

N/S: W/E: I/S No:

AM/PM: **PM** Comments:

COUNT DATE: STUDY DATE: GROWTH FACTOR:

		NORTHBOUND			SOUTHBOUND			WESTBOUND			EASTBOUND		
		LT	TH	RT	LT	TH	RT	LT	TH	RT	LT	TH	RT
EXISTING		30	190	140	230	30	210	30	460	130	60	520	10
AMBIENT													
RELATED													
PROJECT													
TOTAL		30	190	140	230	30	210	30	460	130	60	520	10
LANE		<input type="checkbox"/> <input type="checkbox"/> <input checked="" type="checkbox"/> <input type="checkbox"/> <input type="checkbox"/>			<input type="checkbox"/> <input type="checkbox"/> <input type="checkbox"/> <input checked="" type="checkbox"/> <input type="checkbox"/>			<input type="checkbox"/> <input type="checkbox"/> <input type="checkbox"/> <input type="checkbox"/> <input type="checkbox"/>			<input type="checkbox"/> <input type="checkbox"/> <input type="checkbox"/> <input type="checkbox"/> <input type="checkbox"/>		
SIGNAL		Phasing: <input type="text" value="Perm"/> RTOR: <input type="text" value="Auto"/>			Phasing: <input type="text" value="Perm"/> RTOR: <input type="text" value="Auto"/>			Phasing: <input type="text" value="Perm"/> RTOR: <input type="text" value="Auto"/>			Phasing: <input type="text" value="Perm"/> RTOR: <input type="text" value="Auto"/>		

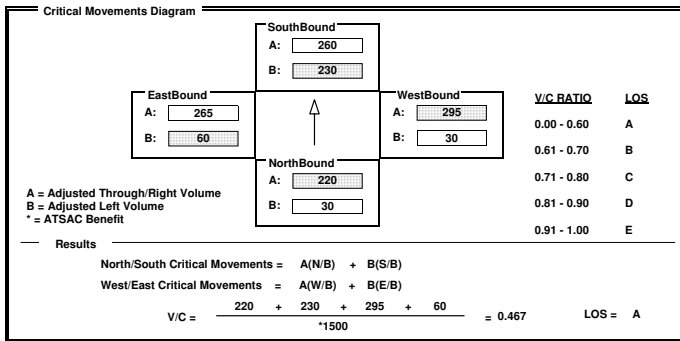

INTERSECTION DATA SUMMARY SHEET

N/S: W/E: I/S No:
 AM/PM: Comments:
 COUNT DATE: STUDY DATE: GROWTH FACTOR:

	NORTHBOUND			SOUTHBOUND			WESTBOUND			EASTBOUND		
	LT	TH	RT	LT	TH	RT	LT	TH	RT	LT	TH	RT
EXISTING	0	630	90	260	850	0	850	0	180	0	0	0
AMBIENT												
RELATED												
PROJECT												
TOTAL	0	630	90	260	850	0	850	0	180	0	0	0
LANE	1 1 1			1 2			1			1		
SIGNAL	Phasing		RTOR	Phasing		RTOR	Phasing		RTOR	Phasing		RTOR
	Prot-Fix		Auto	Prot-Fix		Auto	Split		OLA	Split		Auto

Critical Movements Diagram

EastBound A: 0 B: 0	SouthBound A: 425 B: 260	WestBound A: 515 B: 515	V/C RATIO	LOS
			0.00 - 0.60	A
			0.61 - 0.70	B
			0.71 - 0.80	C
			0.81 - 0.90	D
			0.91 - 1.00	E

A = Adjusted Through/Right Volume
 B = Adjusted Left Volume
 * = ATSAC Benefit

Results

North/South Critical Movements = A(N/B) + B(S/B)
 West/East Critical Movements = A(W/B) + A(E/B)

V/C = $\frac{315 + 260 + 515 + 0}{1375} = 0.723$ LOS = C

INTERSECTION DATA SUMMARY SHEET

N/S: W/E: I/S No:
 AM/PM: Comments:
 COUNT DATE: STUDY DATE: GROWTH FACTOR:

	NORTHBOUND			SOUTHBOUND			WESTBOUND			EASTBOUND		
	LT	TH	RT	LT	TH	RT	LT	TH	RT	LT	TH	RT
EXISTING	0	730	40	670	950	0	0	0	480	0	0	0
AMBIENT												
RELATED												
PROJECT												
TOTAL	0	730	40	670	950	0	0	0	480	0	0	0
LANE	1 1			2 2			2			1 1 1		
SIGNAL	Phasing		RTOR	Phasing		RTOR	Phasing		RTOR	Phasing		RTOR
	Prot-Fix		Auto	Prot-Fix		Auto	Split		OLA	Split		Auto

Critical Movements Diagram

EastBound A: 0 B: 0	SouthBound A: 475 B: 369	WestBound A: 0 B: 0	V/C RATIO	LOS
			0.00 - 0.60	A
			0.61 - 0.70	B
			0.71 - 0.80	C
			0.81 - 0.90	D
			0.91 - 1.00	E

A = Adjusted Through/Right Volume
 B = Adjusted Left Volume
 * = ATSAC Benefit

Results

North/South Critical Movements = A(N/B) + B(S/B)
 West/East Critical Movements = A(W/B) + A(E/B)

V/C = $\frac{385 + 369 + 0 + 0}{1375} = 0.478$ LOS = A

INTERSECTION DATA SUMMARY SHEET

N/S: W/E: I/S No:
 AM/PM: Comments:
 COUNT DATE: STUDY DATE: GROWTH FACTOR:

	NORTHBOUND			SOUTHBOUND			WESTBOUND			EASTBOUND		
	LT	TH	RT	LT	TH	RT	LT	TH	RT	LT	TH	RT
EXISTING	160	2420	180	190	2430	20	130	720	100	40	990	260
AMBIENT												
RELATED												
PROJECT												
TOTAL	160	2420	180	190	2430	20	130	720	100	40	990	260
LANE	2 2 1			1 2 1			1 2 1			2 1		
SIGNAL	Phasing		RTOR	Phasing		RTOR	Phasing		RTOR	Phasing		RTOR
	Prot-Fix		Auto	Prot-Fix		Auto	Prot-Fix		Auto	Perm		Auto

Critical Movements Diagram

EastBound A: 417 B: 0	SouthBound A: 817 B: 190	WestBound A: 360 B: 130	V/C RATIO	LOS
			0.00 - 0.60	A
			0.61 - 0.70	B
			0.71 - 0.80	C
			0.81 - 0.90	D
			0.91 - 1.00	E

A = Adjusted Through/Right Volume
 B = Adjusted Left Volume
 * = ATSAC Benefit

Results

North/South Critical Movements = A(N/B) + B(S/B)
 West/East Critical Movements = B(W/B) + A(E/B)

V/C = $\frac{867 + 190 + 130 + 417}{1375} = 1.097$ LOS = F

INTERSECTION DATA SUMMARY SHEET

N/S: W/E: I/S No:
 AM/PM: Comments:
 COUNT DATE: STUDY DATE: GROWTH FACTOR:

	NORTHBOUND			SOUTHBOUND			WESTBOUND			EASTBOUND		
	LT	TH	RT	LT	TH	RT	LT	TH	RT	LT	TH	RT
EXISTING	70	1460	210	110	1340	180	390	1320	110	140	1090	160
AMBIENT												
RELATED												
PROJECT												
TOTAL	70	1460	210	110	1340	180	390	1320	110	140	1090	160
LANE	1 2 1			1 2 1			1 2 1			1 2 1		
SIGNAL	Phasing		RTOR	Phasing		RTOR	Phasing		RTOR	Phasing		RTOR
	Prot-Fix		Auto	Prot-Fix		Auto	Prot-Fix		Auto	Prot-Fix		Auto

Critical Movements Diagram

EastBound A: 417 B: 140	SouthBound A: 670 B: 110	WestBound A: 477 B: 390	V/C RATIO	LOS
			0.00 - 0.60	A
			0.61 - 0.70	B
			0.71 - 0.80	C
			0.81 - 0.90	D
			0.91 - 1.00	E

A = Adjusted Through/Right Volume
 B = Adjusted Left Volume
 * = ATSAC Benefit

Results

North/South Critical Movements = A(N/B) + B(S/B)
 West/East Critical Movements = B(W/B) + A(E/B)

V/C = $\frac{730 + 110 + 390 + 417}{1375} = 1.128$ LOS = F

INTERSECTION DATA SUMMARY SHEET

N/S: W/E: I/S No:

AM/PM: Comments:

COUNT DATE: STUDY DATE: GROWTH FACTOR:

	NORTHBOUND			SOUTHBOUND			WESTBOUND			EASTBOUND		
	LT	TH	RT	LT	TH	RT	LT	TH	RT	LT	TH	RT
EXISTING	90	680	40	290	870	100	40	800	140	120	1190	110
AMBIENT												
RELATED												
PROJECT												
TOTAL	90	680	40	290	870	100	40	800	140	120	1190	110
LANE	1 1 1			1 2 1			1 2 1			1 2 1		
SIGNAL	Prot-Fix		Auto	Prot-Fix		Auto	Prot-Fix		Auto	Prot-Fix		Auto

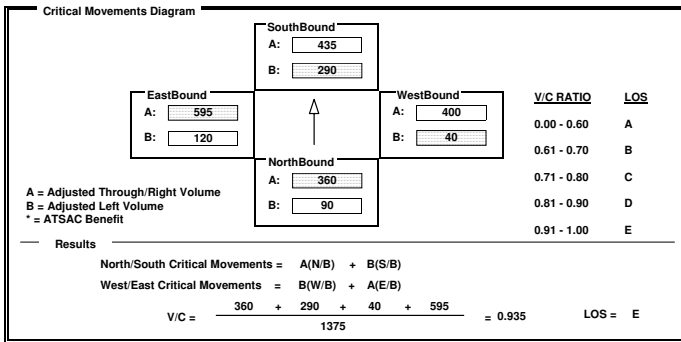

INTERSECTION DATA SUMMARY SHEET

N/S: W/E: I/S No:

AM/PM: Comments:

COUNT DATE: STUDY DATE: GROWTH FACTOR:

	NORTHBOUND			SOUTHBOUND			WESTBOUND			EASTBOUND		
	LT	TH	RT	LT	TH	RT	LT	TH	RT	LT	TH	RT
EXISTING	0	2540	1350	410	0	0	780	0	100	0	0	0
AMBIENT												
RELATED												
PROJECT												
TOTAL	0	2540	1350	410	0	0	780	0	100	0	0	0
LANE	2 1 1			1 1 1			2 1 1			1 1 1		
SIGNAL	Prot-Fix		Auto	Prot-Fix			Split		Free	Prot-Fix		

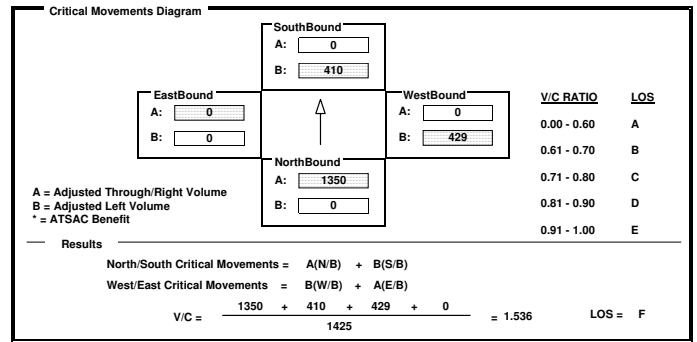

INTERSECTION DATA SUMMARY SHEET

N/S: W/E: I/S No:

AM/PM: Comments:

COUNT DATE: STUDY DATE: GROWTH FACTOR:

	NORTHBOUND			SOUTHBOUND			WESTBOUND			EASTBOUND		
	LT	TH	RT	LT	TH	RT	LT	TH	RT	LT	TH	RT
EXISTING	160	1220	220	130	1080	170	280	1440	180	300	1330	180
AMBIENT												
RELATED												
PROJECT												
TOTAL	160	1220	220	130	1080	170	280	1440	180	300	1330	180
LANE	1 2 1			1 2 1			2 2 1			2 2 1		
SIGNAL	Prot-Fix		OLA	Prot-Fix		OLA	Prot-Fix		Auto	Prot-Fix		Auto

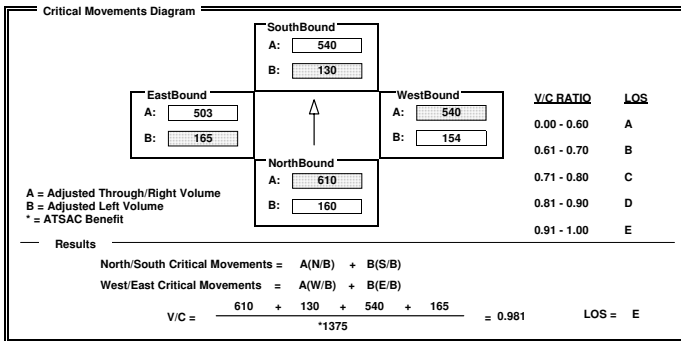

INTERSECTION DATA SUMMARY SHEET

N/S: W/E: I/S No:

AM/PM: Comments:

COUNT DATE: STUDY DATE: GROWTH FACTOR:

	NORTHBOUND			SOUTHBOUND			WESTBOUND			EASTBOUND		
	LT	TH	RT	LT	TH	RT	LT	TH	RT	LT	TH	RT
EXISTING	150	1530	50	120	1490	190	70	270	90	180	460	190
AMBIENT												
RELATED												
PROJECT												
TOTAL	150	1530	50	120	1490	190	70	270	90	180	460	190
LANE	1 2 1			1 2 1			1 1 1			1 1 1		
SIGNAL	Perm		Auto	Perm		Auto	Perm		Auto	Perm		Auto

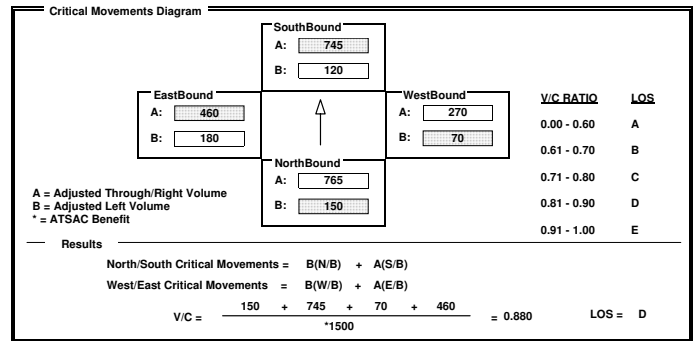

INTERSECTION DATA SUMMARY SHEET

N/S: Western Ave W/E: Century Blvd I/S No: 161
 AM/PM: PM Comments: Cumulative (2013) Adjusted W/O Project
 COUNT DATE: STUDY DATE: GROWTH FACTOR:

	NORTHBOUND			SOUTHBOUND			WESTBOUND			EASTBOUND		
	LT	TH	RT	LT	TH	RT	LT	TH	RT	LT	TH	RT
EXISTING	110	860	170	140	810	170	140	970	170	190	1240	160
AMBIENT												
RELATED												
PROJECT												
TOTAL	110	860	170	140	810	170	140	970	170	190	1240	160
LANE	1	2	1	1	1	1	1	2	1	1	2	1
Phasing	Prot-Fix		OLA	Prot-Fix		Auto	Prot-Fix		Auto	Prot-Fix		Auto
SIGNAL	Prot-Fix		OLA	Prot-Fix		Auto	Prot-Fix		Auto	Prot-Fix		Auto

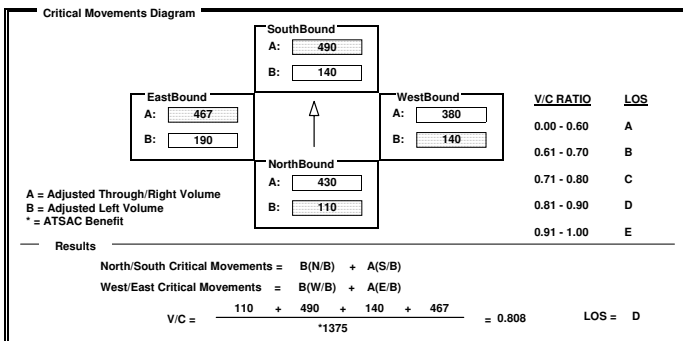

INTERSECTION DATA SUMMARY SHEET

N/S: La Cienega Blvd W/E: Jefferson Blvd I/S No: 200
 AM/PM: PM Comments: Cumulative (2013) Adjusted W/O Project
 COUNT DATE: STUDY DATE: GROWTH FACTOR:

	NORTHBOUND			SOUTHBOUND			WESTBOUND			EASTBOUND		
	LT	TH	RT	LT	TH	RT	LT	TH	RT	LT	TH	RT
EXISTING	80	2340	330	80	2330	300	400	480	70	640	750	230
AMBIENT												
RELATED												
PROJECT												
TOTAL	80	2340	330	80	2330	300	400	480	70	640	750	230
LANE	1	2	1	1	3	1	2	2	1	2	1	1
Phasing	Perm		Auto	Perm		OLA	Prot-Fix		Auto	Prot-Fix		Auto
SIGNAL	Perm		Auto	Perm		OLA	Prot-Fix		Auto	Prot-Fix		Auto

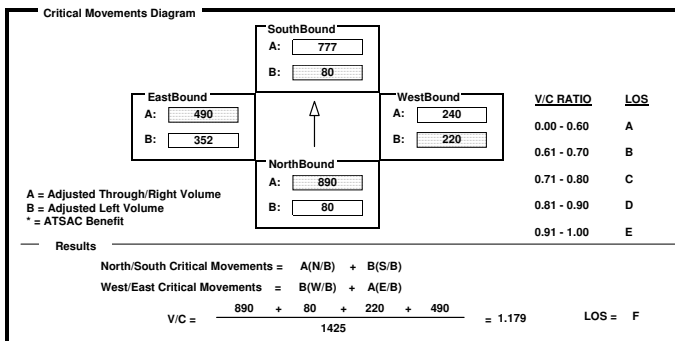

Project Title: Bradley West Project
Intersection: 12 - Arbor Vitae St and La Brea Ave
Description: Future-Adjusted (2013) Without Project Conditions
Date/Time: AM PEAK HOUR

Thru Lane: 1600 vph N-S Split Phase : N
 Left Lane: 1600 vph E-W Split Phase : N
 Double Lt Penalty: 20 % Lost Time (% of cycle) : 10
 ITS: 0 % V/C Round Off (decs.) : 3
 OLA Movements :
 FF Movements :

APPROACH	MVMT	LANES	VOLUME	CAPACITY	V/C	ICU ANALYSIS
Southbound	RT	1.00	40	1,600	0.003	N-S(1): 0.189
	TH	3.00	490	4,800	0.102 *	N-S(2): 0.215 *
	LT	1.00	50	1,600	0.031	E-W(1): 0.182 *
Westbound	RT	1.00	70	1,600	0.028	E-W(2): 0.150
	TH	2.00	340	3,200	0.106	V/C: 0.397
	LT	1.00	50	1,600	0.038 *	Lost Time: 0.100
Northbound	RT	0.00	30	0	0.000	ITS: 0.000
	TH	3.00	730	4,800	0.158	ICU: 0.497
	LT	1.00	180	1,600	0.113 *	LOS: A
Eastbound	RT	1.00	130	1,600	0.025	
	TH	1.00	230	1,600	0.144 *	
	LT	1.00	70	1,600	0.044	

Date/Time: MD PEAK HOUR

APPROACH	MVMT	LANES	VOLUME	CAPACITY	V/C	ICU ANALYSIS
Southbound	RT	1.00	50	1,600	0.006	N-S(1): 0.202
	TH	3.00	670	4,800	0.140 *	N-S(2): 0.253 *
	LT	1.00	120	1,600	0.075	E-W(1): 0.182 *
Westbound	RT	1.00	70	1,600	0.006	E-W(2): 0.116
	TH	2.00	210	3,200	0.066	V/C: 0.435
	LT	1.00	60	1,600	0.038 *	Lost Time: 0.100
Northbound	RT	0.00	70	0	0.000	ITS: 0.000
	TH	3.00	540	4,800	0.127 *	ICU: 0.535
	LT	1.00	190	1,600	0.113 *	LOS: A
Eastbound	RT	1.00	170	1,600	0.050	
	TH	1.00	230	1,600	0.144 *	
	LT	1.00	80	1,600	0.050	

Date/Time: PM PEAK HOUR

APPROACH	MVMT	LANES	VOLUME	CAPACITY	V/C	ICU ANALYSIS
Southbound	RT	1.00	50	1,600	0.006	N-S(1): 0.217
	TH	3.00	940	4,800	0.196 *	N-S(2): 0.334 *
	LT	1.00	100	1,600	0.063	E-W(1): 0.313 *
Westbound	RT	1.00	40	1,600	0.000	E-W(2): 0.128
	TH	2.00	250	3,200	0.078	V/C: 0.647
	LT	1.00	60	1,600	0.038 *	Lost Time: 0.100
Northbound	RT	0.00	70	0	0.000	ITS: 0.000
	TH	3.00	670	4,800	0.154 *	ICU: 0.747
	LT	1.00	220	1,600	0.138 *	LOS: C
Eastbound	RT	1.00	210	1,600	0.063	
	TH	1.00	440	1,600	0.275 *	
	LT	1.00	80	1,600	0.050	

* - Denotes critical movement

Project Title: Bradley West Project
Intersection: 13 - Arbor Vitae St and La Cienega Blvd
Description: Future-Adjusted (2013) Without Project Conditions
Date/Time: AM PEAK HOUR

Thru Lane: 1600 vph N-S Split Phase : N
 Left Lane: 1600 vph E-W Split Phase : N
 Double Lt Penalty: 20 % Lost Time (% of cycle) : 10
 ITS: 10 % V/C Round Off (decs.) : 3
 OLA Movements :
 FF Movements :

APPROACH	MVMT	LANES	VOLUME	CAPACITY	V/C	ICU ANALYSIS
Southbound	RT	0.00	70	0	0.000	N-S(1): 0.279
	TH	2.00	320	3,200	0.122 *	N-S(2): 0.403 *
	LT	1.00	60	1,600	0.038	E-W(1): 0.207
Westbound	RT	1.00	170	1,600	0.106	E-W(2): 0.285 *
	TH	2.00	770	3,200	0.241 *	V/C: 0.688
	LT	1.00	150	1,600	0.094	Lost Time: 0.100
Northbound	RT	0.00	70	0	0.000	ITS: -0.100
	TH	2.00	700	3,200	0.241	ICU: 0.688
	LT	1.00	450	1,600	0.281 *	LOS: B
Eastbound	RT	0.00	140	0	0.000	
	TH	2.00	220	3,200	0.113	
	LT	1.00	70	1,600	0.044 *	

Date/Time: MD PEAK HOUR

APPROACH	MVMT	LANES	VOLUME	CAPACITY	V/C	ICU ANALYSIS
Southbound	RT	0.00	90	0	0.000	N-S(1): 0.197
	TH	2.00	530	3,200	0.194 *	N-S(2): 0.325 *
	LT	1.00	100	1,600	0.063	E-W(1): 0.225 *
Westbound	RT	1.00	80	1,600	0.050	E-W(2): 0.160
	TH	2.00	310	3,200	0.097	V/C: 0.550
	LT	1.00	70	1,600	0.044 *	Lost Time: 0.100
Northbound	RT	0.00	90	0	0.000	ITS: -0.100
	TH	2.00	340	3,200	0.134	ICU: 0.550
	LT	1.00	210	1,600	0.131 *	LOS: A
Eastbound	RT	0.00	280	0	0.000	
	TH	2.00	300	3,200	0.181 *	
	LT	1.00	100	1,600	0.063	

Date/Time: PM PEAK HOUR

APPROACH	MVMT	LANES	VOLUME	CAPACITY	V/C	ICU ANALYSIS
Southbound	RT	0.00	80	0	0.000	N-S(1): 0.288
	TH	2.00	580	3,200	0.206 *	N-S(2): 0.331 *
	LT	1.00	110	1,600	0.069	E-W(1): 0.438 *
Westbound	RT	1.00	80	1,600	0.050	E-W(2): 0.166
	TH	2.00	310	3,200	0.097	V/C: 0.769
	LT	1.00	70	1,600	0.044 *	Lost Time: 0.100
Northbound	RT	0.00	230	0	0.000	ITS: -0.100
	TH	2.00	470	3,200	0.219	ICU: 0.769
	LT	1.00	200	1,600	0.125 *	LOS: C
Eastbound	RT	0.00	630	1,600	0.394 *	
	TH	2.00	570	1,600	0.356	
	LT	1.00	110	1,600	0.069	

* - Denotes critical movement

Project Title: Bradley West Project						
Intersection: 17 - Aviation Bl / Florence Ave and Manchester Bl						
Description: Future-Adjusted (2013) Without Project Conditions						
Date/Time: AM PEAK HOUR						
Thru Lane: 1600 vph		N-S Split Phase : N				
Left Lane: 1600 vph		E-W Split Phase : N				
Double Lt Penalty: 20 %		Lost Time (% of cycle) : 10				
ITS: 10 %		V/C Round Off (decs.) : 3				
OLA Movements :						
FF Movements:						
APPROACH	MVMT	LANES	VOLUME	CAPACITY	V/C	ICU ANALYSIS
Southbound	RT	1.00	380	1,600	0.191 *	N-S(1): 0.175 N-S(2): 0.366 * E-W(1): 0.234 E-W(2): 0.413 *
	TH	2.00	390	3,200	0.125	
	LT	0.00	10	1,600	0.006	
Westbound	RT	1.00	10	1,600	0.003	V/C: 0.779 Lost Time: 0.100 ITS: -0.100
	TH	2.00	1,020	3,200	0.319 *	
	LT	1.00	90	1,600	0.056	
Northbound	RT	0.00	270	0	0.000	ICU: 0.779 LOS: C
	TH	2.00	270	3,200	0.169	
	LT	1.00	280	1,600	0.175 *	
Eastbound	RT	1.00	130	1,600	0.050	
	TH	2.00	570	3,200	0.178	
	LT	1.00	150	1,600	0.094 *	
Date/Time: MD PEAK HOUR						
APPROACH	MVMT	LANES	VOLUME	CAPACITY	V/C	ICU ANALYSIS
Southbound	RT	1.00	280	1,600	0.078	N-S(1): 0.128 N-S(2): 0.241 * E-W(1): 0.363 E-W(2): 0.391 *
	TH	2.00	280	3,200	0.091 *	
	LT	0.00	10	1,600	0.006	
Westbound	RT	1.00	30	1,600	0.016	V/C: 0.632 Lost Time: 0.100 ITS: -0.100
	TH	2.00	630	3,200	0.197 *	
	LT	1.00	100	1,600	0.063	
Northbound	RT	0.00	190	0	0.000	ICU: 0.632 LOS: B
	TH	2.00	200	3,200	0.122	
	LT	1.00	240	1,600	0.150 *	
Eastbound	RT	1.00	160	1,600	0.025	
	TH	2.00	960	3,200	0.300	
	LT	1.00	310	1,600	0.194 *	
Date/Time: PM PEAK HOUR						
APPROACH	MVMT	LANES	VOLUME	CAPACITY	V/C	ICU ANALYSIS
Southbound	RT	1.00	250	1,600	0.063	N-S(1): 0.165 N-S(2): 0.281 * E-W(1): 0.409 E-W(2): 0.422 *
	TH	2.00	410	3,200	0.131 *	
	LT	0.00	10	1,600	0.006	
Westbound	RT	1.00	29	1,600	0.009	V/C: 0.703 Lost Time: 0.100 ITS: -0.100
	TH	2.00	750	3,200	0.234 *	
	LT	1.00	90	1,600	0.056	
Northbound	RT	0.00	130	0	0.000	ICU: 0.703 LOS: C
	TH	2.00	380	3,200	0.159	
	LT	1.00	240	1,600	0.150 *	
Eastbound	RT	1.00	190	1,600	0.044	
	TH	2.00	1,130	3,200	0.353	
	LT	1.00	300	1,600	0.188 *	

* - Denotes critical movement

Project Title: Bradley West Project						
Intersection: 28 - Centinela Ave and Sepulveda Blvd						
Description: Future-Adjusted (2013) Without Project Conditions						
Date/Time: AM PEAK HOUR						
Thru Lane: 1600 vph		N-S Split Phase : N				
Left Lane: 1600 vph		E-W Split Phase : N				
Double Lt Penalty: 20 %		Lost Time (% of cycle) : 10				
ITS: 10 %		V/C Round Off (decs.) : 3				
OLA Movements :						
FF Movements:						
APPROACH	MVMT	LANES	VOLUME	CAPACITY	V/C	ICU ANALYSIS
Southbound	RT	1.00	180	1,600	0.078	N-S(1): 0.308 N-S(2): 0.434 * E-W(1): 0.171 E-W(2): 0.363 *
	TH	3.00	580	4,800	0.121 *	
	LT	2.00	70	2,560	0.027	
Westbound	RT	0.00	220	0	0.000	V/C: 0.797 Lost Time: 0.100 ITS: -0.100
	TH	2.00	720	3,200	0.224 *	
	LT	2.00	320	2,560	0.123	
Northbound	RT	1.00	230	1,600	0.081	ICU: 0.797 LOS: C
	TH	3.00	1,350	4,800	0.281 *	
	LT	2.00	800	2,560	0.313 *	
Eastbound	RT	2.00	440	3,200	0.050	
	TH	3.00	220	4,800	0.046	
	LT	1.00	110	1,600	0.069 *	
Date/Time: MD PEAK HOUR						
APPROACH	MVMT	LANES	VOLUME	CAPACITY	V/C	ICU ANALYSIS
Southbound	RT	1.00	90	1,600	0.009	N-S(1): 0.298 N-S(2): 0.342 * E-W(1): 0.229 E-W(2): 0.285 *
	TH	3.00	910	4,800	0.190 *	
	LT	2.00	230	2,560	0.090	
Westbound	RT	0.00	170	0	0.000	V/C: 0.627 Lost Time: 0.100 ITS: -0.100
	TH	2.00	440	3,200	0.191 *	
	LT	2.00	390	2,560	0.152	
Northbound	RT	1.00	230	1,600	0.068	ICU: 0.627 LOS: B
	TH	3.00	1,000	4,800	0.208	
	LT	2.00	390	2,560	0.152 *	
Eastbound	RT	2.00	700	3,200	0.066	
	TH	3.00	370	4,800	0.077	
	LT	1.00	150	1,600	0.094 *	
Date/Time: PM PEAK HOUR						
APPROACH	MVMT	LANES	VOLUME	CAPACITY	V/C	ICU ANALYSIS
Southbound	RT	1.00	160	1,600	0.019	N-S(1): 0.328 N-S(2): 0.494 * E-W(1): 0.291 E-W(2): 0.319 *
	TH	3.00	1,320	4,800	0.275 *	
	LT	2.00	190	2,560	0.074	
Westbound	RT	0.00	130	0	0.000	V/C: 0.813 Lost Time: 0.100 ITS: -0.100
	TH	2.00	370	3,200	0.156 *	
	LT	2.00	360	2,560	0.141	
Northbound	RT	1.00	280	1,600	0.105	ICU: 0.813 LOS: D
	TH	3.00	1,220	4,800	0.254	
	LT	2.00	560	2,560	0.219 *	
Eastbound	RT	2.00	900	3,200	0.063	
	TH	3.00	720	4,800	0.150	
	LT	1.00	260	1,600	0.163 *	

* - Denotes critical movement

Project Title: Bradley West Project						
Intersection: 34 - Century Blvd and Hawthorne Blvd / La Brea Ave						
Description: Future-Adjusted (2013) Without Project Conditions						
Date/Time: AM PEAK HOUR						
Thru Lane: 1600 vph		N-S Split Phase : N				
Left Lane: 1600 vph		E-W Split Phase : N				
Double Lt Penalty: 20 %		Lost Time (% of cycle) : 10				
ITS: 0 %		V/C Round Off (decs.) : 3				
OLA Movements :						
FF Movements:						
APPROACH	MVMT	LANES	VOLUME	CAPACITY	V/C	ICU ANALYSIS
Southbound	RT	1.00	160	1,600	0.069	N-S(1): 0.213 N-S(2): 0.248 * E-W(1): 0.231 E-W(2): 0.303 *
	TH	3.00	530	4,800	0.110 *	
	LT	1.00	80	1,600	0.050	
Westbound	RT	0.00	110	0	0.000	V/C: 0.551 Lost Time: 0.100 ITS: 0.000
	TH	3.00	1,040	4,800	0.240 *	
	LT	1.00	90	1,600	0.050	
Northbound	RT	1.00	90	1,600	0.031	ICU: 0.651 LOS: B
	TH	3.00	780	4,800	0.163	
	LT	1.00	220	1,600	0.138 *	
Eastbound	RT	0.00	290	1,600	0.181	
	TH	3.00	450	3,200	0.141	
	LT	1.00	100	1,600	0.063 *	
Date/Time: MD PEAK HOUR						
APPROACH	MVMT	LANES	VOLUME	CAPACITY	V/C	ICU ANALYSIS
Southbound	RT	1.00	120	1,600	0.031	N-S(1): 0.236 N-S(2): 0.259 * E-W(1): 0.292 *
	TH	3.00	670	4,800	0.140 *	
	LT	1.00	190	1,600	0.119	
Westbound	RT	0.00	140	0	0.000	V/C: 0.551 Lost Time: 0.100 ITS: 0.000
	TH	3.00	670	4,800	0.169	
	LT	1.00	160	1,600	0.100 *	
Northbound	RT	1.00	180	1,600	0.063	ICU: 0.651 LOS: B
	TH	3.00	560	4,800	0.117	
	LT	1.00	190	1,600	0.119 *	
Eastbound	RT	0.00	200	0	0.000	
	TH	3.00	720	4,800	0.192 *	
	LT	1.00	140	1,600	0.088	
Date/Time: PM PEAK HOUR						
APPROACH	MVMT	LANES	VOLUME	CAPACITY	V/C	ICU ANALYSIS
Southbound	RT	1.00	130	1,600	0.041	N-S(1): 0.275 N-S(2): 0.332 * E-W(1): 0.429 *
	TH	3.00	1,020	4,800	0.213 *	
	LT	1.00	200	1,600	0.125	
Westbound	RT	0.00	160	0	0.000	V/C: 0.761 Lost Time: 0.100 ITS: 0.000
	TH	3.00	670	4,800	0.169	
	LT	1.00	160	1,600	0.100 *	
Northbound	RT	1.00	200	1,600	0.075	ICU: 0.861 LOS: D
	TH	3.00	720	4,800	0.150	
	LT	1.00	190	1,600	0.119 *	
Eastbound	RT	0.00	320	0	0.000	
	TH	3.00	1,260	4,800	0.329 *	
	LT	1.00	130	1,600	0.081	

* - Denotes critical movement

Project Title: Bradley West Project						
Intersection: 35 - Century Blvd and Inglewood Ave						
Description: Future-Adjusted (2013) Without Project Conditions						
Date/Time: AM PEAK HOUR						
Thru Lane: 1600 vph		N-S Split Phase : N				
Left Lane: 1600 vph		E-W Split Phase : N				
Double Lt Penalty: 20 %		Lost Time (% of cycle) : 10				
ITS: 0 %		V/C Round Off (decs.) : 3				
OLA Movements :						
FF Movements:						
APPROACH	MVMT	LANES	VOLUME	CAPACITY	V/C	ICU ANALYSIS
Southbound	RT	1.00	100	1,600	0.024	N-S(1): 0.187 N-S(2): 0.219 * E-W(1): 0.217 E-W(2): 0.364 *
	TH	1.00	190	1,600	0.119 *	
	LT	1.00	50	1,600	0.031	
Westbound	RT	0.00	90	0	0.000	V/C: 0.583 Lost Time: 0.100 ITS: 0.000
	TH	3.00	1,390	4,800	0.398 *	
	LT	1.00	80	1,600	0.050	
Northbound	RT	1.00	60	1,600	0.013	ICU: 0.683 LOS: B
	TH	1.00	250	1,600	0.156	
	LT	1.00	160	1,600	0.100 *	
Eastbound	RT	0.00	90	0	0.000	
	TH	3.00	720	4,800	0.167	
	LT	1.00	90	1,600	0.056 *	
Date/Time: MD PEAK HOUR						
APPROACH	MVMT	LANES	VOLUME	CAPACITY	V/C	ICU ANALYSIS
Southbound	RT	1.00	100	1,600	0.028	N-S(1): 0.181 N-S(2): 0.194 * E-W(1): 0.250 E-W(2): 0.269 *
	TH	1.00	220	1,600	0.138 *	
	LT	1.00	80	1,600	0.050	
Westbound	RT	0.00	100	0	0.000	V/C: 0.463 Lost Time: 0.100 ITS: 0.000
	TH	3.00	860	4,800	0.200 *	
	LT	1.00	70	1,600	0.044	
Northbound	RT	1.00	90	1,600	0.034	ICU: 0.563 LOS: A
	TH	1.00	210	1,600	0.131	
	LT	1.00	90	1,600	0.056 *	
Eastbound	RT	0.00	120	0	0.000	
	TH	3.00	870	4,800	0.206	
	LT	1.00	110	1,600	0.069 *	
Date/Time: PM PEAK HOUR						
APPROACH	MVMT	LANES	VOLUME	CAPACITY	V/C	ICU ANALYSIS
Southbound	RT	1.00	100	1,600		

Project Title: Bradley West Project
Intersection: 37 - Century Blvd and Prairie Ave
Description: Future-Adjusted (2013) Without Project Conditions

Date/Time: AM PEAK HOUR

Thru Lane: 1600 vph N-S Split Phase : N
 Left Lane: 1600 vph E-W Split Phase : N
 Double Lt Penalty: 20 % Last Time (% of cycle) : 10
 ITS: 0 % V/C Round Off (decs.) : 3
 OLA Movements :
 FF Movements :

APPROACH	MVMT	LANES	VOLUME	CAPACITY	V/C	ICU ANALYSIS
Southbound	RT	0.00	90	0	0.000	N-S(1): 0.327 * N-S(2): 0.271 * E-W(1): 0.137 * E-W(2): 0.302 * V/C: 0.629 Lost Time: 0.100 ITS: 0.000 ICU: 0.729 LOS: C
	TH	3.00	700	4,800	0.165	
	LT	1.00	210	1,600	0.131 *	
Westbound	RT	0.00	290	0	0.000	V/C: 0.629 Lost Time: 0.100 ITS: 0.000 ICU: 0.729 LOS: C
	TH	3.00	890	4,800	0.246 *	
	LT	1.00	50	1,600	0.031 *	
Northbound	RT	0.00	80	0	0.000	V/C: 0.629 Lost Time: 0.100 ITS: 0.000 ICU: 0.729 LOS: C
	TH	3.00	860	4,800	0.196 *	
	LT	1.00	170	1,600	0.106	
Eastbound	RT	0.00	110	0	0.000	V/C: 0.629 Lost Time: 0.100 ITS: 0.000 ICU: 0.729 LOS: C
	TH	3.00	400	4,800	0.106	
	LT	1.00	90	1,600	0.056 *	

Date/Time: MD PEAK HOUR

APPROACH	MVMT	LANES	VOLUME	CAPACITY	V/C	ICU ANALYSIS
Southbound	RT	0.00	90	0	0.000	N-S(1): 0.351 * N-S(2): 0.236 * E-W(1): 0.273 * E-W(2): 0.283 * V/C: 0.634 Lost Time: 0.100 ITS: 0.000 ICU: 0.734 LOS: C
	TH	3.00	590	4,800	0.142	
	LT	1.00	260	1,600	0.163 *	
Westbound	RT	0.00	300	0	0.000	V/C: 0.634 Lost Time: 0.100 ITS: 0.000 ICU: 0.734 LOS: C
	TH	3.00	670	4,800	0.202 *	
	LT	1.00	150	1,600	0.094	
Northbound	RT	0.00	160	0	0.000	V/C: 0.634 Lost Time: 0.100 ITS: 0.000 ICU: 0.734 LOS: C
	TH	3.00	740	4,800	0.188 *	
	LT	1.00	150	1,600	0.094	
Eastbound	RT	0.00	130	0	0.000	V/C: 0.634 Lost Time: 0.100 ITS: 0.000 ICU: 0.734 LOS: C
	TH	3.00	730	4,800	0.179	
	LT	1.00	130	1,600	0.081 *	

Date/Time: PM PEAK HOUR

APPROACH	MVMT	LANES	VOLUME	CAPACITY	V/C	ICU ANALYSIS
Southbound	RT	0.00	130	0	0.000	N-S(1): 0.396 * N-S(2): 0.387 * E-W(1): 0.429 * E-W(2): 0.292 * V/C: 0.825 Lost Time: 0.100 ITS: 0.000 ICU: 0.925 LOS: E
	TH	3.00	1,340	4,800	0.306	
	LT	1.00	300	1,600	0.188 *	
Westbound	RT	0.00	340	0	0.000	V/C: 0.825 Lost Time: 0.100 ITS: 0.000 ICU: 0.925 LOS: E
	TH	3.00	760	4,800	0.229	
	LT	1.00	200	1,600	0.125 *	
Northbound	RT	0.00	180	0	0.000	V/C: 0.825 Lost Time: 0.100 ITS: 0.000 ICU: 0.925 LOS: E
	TH	3.00	820	4,800	0.208 *	
	LT	1.00	130	1,600	0.081	
Eastbound	RT	0.00	250	0	0.000	V/C: 0.825 Lost Time: 0.100 ITS: 0.000 ICU: 0.925 LOS: E
	TH	3.00	1,210	4,800	0.304 *	
	LT	1.00	100	1,600	0.063	

* - Denotes critical movement

Project Title: Bradley West Project
Intersection: 39 - Century Blvd and I-405 NB On/Off Ramps
Description: Future-Adjusted (2013) Without Project Conditions

Date/Time: AM PEAK HOUR

Thru Lane: 1600 vph N-S Split Phase : Y
 Left Lane: 1600 vph E-W Split Phase : N
 Double Lt Penalty: 20 % Last Time (% of cycle) : 10
 ITS: 10 % V/C Round Off (decs.) : 3
 OLA Movements :
 FF Movements :

APPROACH	MVMT	LANES	VOLUME	CAPACITY	V/C	ICU ANALYSIS
Southbound	RT	0.00	0	0	0.000	N-S(1): 0.402 * N-S(2): 0.000 * E-W(1): 0.188 * E-W(2): 0.385 * V/C: 0.787 Lost Time: 0.100 ITS: -0.100 ICU: 0.787 LOS: C
	TH	3.00	0	0	0.000	
	LT	0.00	0	0	0.000 *	
Westbound	RT	0.00	520	0	0.000	V/C: 0.787 Lost Time: 0.100 ITS: -0.100 ICU: 0.787 LOS: C
	TH	3.00	1,330	4,800	0.385 *	
	LT	0.00	0	0	0.000	
Northbound	RT	1.00	170	1,600	0.106	V/C: 0.787 Lost Time: 0.100 ITS: -0.100 ICU: 0.787 LOS: C
	TH	0.00	0	0	0.000 *	
	LT	2.00	1,030	2,560	0.402 *	
Eastbound	RT	1.30	390	2,080	0.188	V/C: 0.787 Lost Time: 0.100 ITS: -0.100 ICU: 0.787 LOS: C
	TH	2.70	810	4,320	0.188	
	LT	1.00	0	1,600	0.000 *	

Date/Time: MD PEAK HOUR

APPROACH	MVMT	LANES	VOLUME	CAPACITY	V/C	ICU ANALYSIS
Southbound	RT	0.00	0	0	0.000	N-S(1): 0.254 * N-S(2): 0.000 * E-W(1): 0.314 * E-W(2): 0.269 * V/C: 0.568 Lost Time: 0.100 ITS: -0.100 ICU: 0.568 LOS: A
	TH	0.00	0	0	0.000	
	LT	0.00	0	0	0.000 *	
Westbound	RT	0.00	360	0	0.000	V/C: 0.568 Lost Time: 0.100 ITS: -0.100 ICU: 0.568 LOS: A
	TH	3.00	930	4,800	0.269	
	LT	0.00	0	0	0.000 *	
Northbound	RT	1.00	200	1,600	0.125	V/C: 0.568 Lost Time: 0.100 ITS: -0.100 ICU: 0.568 LOS: A
	TH	0.00	0	0	0.000	
	LT	2.00	650	2,560	0.254 *	
Eastbound	RT	1.81	910	2,898	0.314	V/C: 0.568 Lost Time: 0.100 ITS: -0.100 ICU: 0.568 LOS: A
	TH	2.19	1,100	3,502	0.314 *	
	LT	1.00	0	1,600	0.000	

Date/Time: PM PEAK HOUR

APPROACH	MVMT	LANES	VOLUME	CAPACITY	V/C	ICU ANALYSIS
Southbound	RT	0.00	0	0	0.000	N-S(1): 0.256 * N-S(2): 0.000 * E-W(1): 0.388 * E-W(2): 0.217 * V/C: 0.644 Lost Time: 0.100 ITS: -0.100 ICU: 0.644 LOS: B
	TH	0.00	0	0	0.000	
	LT	0.00	0	0	0.000 *	
Westbound	RT	0.00	320	0	0.000	V/C: 0.644 Lost Time: 0.100 ITS: -0.100 ICU: 0.644 LOS: B
	TH	3.00	720	4,800	0.217	
	LT	0.00	0	0	0.000 *	
Northbound	RT	1.00	410	1,600	0.256 *	V/C: 0.644 Lost Time: 0.100 ITS: -0.100 ICU: 0.644 LOS: B
	TH	0.00	0	0	0.000	
	LT	2.00	460	2,560	0.180	
Eastbound	RT	1.05	650	1,677	0.388	V/C: 0.644 Lost Time: 0.100 ITS: -0.100 ICU: 0.644 LOS: B
	TH	2.95	1,830	4,723	0.388 *	
	LT	1.00	0	1,600	0.000	

* - Denotes critical movement

Project Title: Bradley West Project
Intersection: 43 - Culver Blvd and Overland Ave
Description: Future-Adjusted (2013) Without Project Conditions

Date/Time: AM PEAK HOUR

Thru Lane: 1600 vph N-S Split Phase : N
 Left Lane: 1600 vph E-W Split Phase : N
 Double Lt Penalty: 20 % Last Time (% of cycle) : 10
 ITS: 7 % V/C Round Off (decs.) : 3
 OLA Movements :
 FF Movements :

APPROACH	MVMT	LANES	VOLUME	CAPACITY	V/C	ICU ANALYSIS
Southbound	RT	1.00	130	1,600	0.000	N-S(1): 0.380 * N-S(2): 0.251 * E-W(1): 0.240 * E-W(2): 0.384 * V/C: 0.764 Lost Time: 0.100 ITS: -0.070 ICU: 0.794 LOS: C
	TH	2.00	300	3,200	0.188	
	LT	2.00	140	2,560	0.055 *	
Westbound	RT	0.00	190	0	0.000	V/C: 0.764 Lost Time: 0.100 ITS: -0.070 ICU: 0.794 LOS: C
	TH	2.00	460	3,200	0.203 *	
	LT	2.00	170	1,600	0.202 *	
Northbound	RT	0.00	170	0	0.000	V/C: 0.764 Lost Time: 0.100 ITS: -0.070 ICU: 0.794 LOS: C
	TH	2.00	870	3,200	0.325 *	
	LT	2.00	160	2,560	0.063	
Eastbound	RT	1.00	90	1,600	0.025	V/C: 0.764 Lost Time: 0.100 ITS: -0.070 ICU: 0.794 LOS: C
	TH	2.00	430	3,200	0.134	
	LT	1.00	290	1,600	0.181 *	

Date/Time: MD PEAK HOUR

APPROACH	MVMT	LANES	VOLUME	CAPACITY	V/C	ICU ANALYSIS
Southbound	RT	1.00	60	1,600	0.000	N-S(1): 0.376 * N-S(2): 0.251 * E-W(1): 0.219 * E-W(2): 0.228 * V/C: 0.604 Lost Time: 0.100 ITS: -0.070 ICU: 0.634 LOS: B
	TH	2.00	580	3,200	0.181	
	LT	2.00	130	2,560	0.051 *	
Westbound	RT	0.00	110	0	0.000	V/C: 0.604 Lost Time: 0.100 ITS: -0.070 ICU: 0.634 LOS: B
	TH	2.00	360	3,200	0.147 *	
	LT	1.00	160	1,600	0.100	
Northbound	RT	0.00	130	0	0.000	V/C: 0.604 Lost Time: 0.100 ITS: -0.070 ICU: 0.634 LOS: B
	TH	2.00	910	3,200	0.325 *	
	LT	2.00	180	2,560	0.070	
Eastbound	RT	1.00	80	1,600	0.015	V/C: 0.604 Lost Time: 0.100 ITS: -0.070 ICU: 0.634 LOS: B
	TH	2.00	380	3,200	0.119	
	LT	1.00	130	1,600	0.081 *	

Date/Time: PM PEAK HOUR

APPROACH	MVMT	LANES	VOLUME	CAPACITY	V/C	ICU ANALYSIS
Southbound	RT	1.00	220	1,600	0.059	N-S(1): 0.502 * N-S(2): 0.582 * E-W(1): 0.379 * E-W(2): 0.331 * V/C: 0.941 Lost Time: 0.100 ITS: -0.070 ICU: 0.971 LOS: E
	TH	2.00	1,410	3,200	0.441 *	
	LT	2.00	140	2,560	0.055	
Westbound	RT	0.00	220	0	0.000	V/C: 0.941 Lost Time: 0.100 ITS: -0.070 ICU: 0.971 LOS: E
	TH	2.00	340	3,200	0.175	
	LT	1.00	300	1,600	0.188 *	
Northbound	RT	0.00	260	0	0.000	V/C: 0.941 Lost Time: 0.100 ITS: -0.070 ICU: 0.971 LOS: E
	TH	2.00	1,170	3,200	0.447	
	LT	2.00	310	2,560	0.121 *	
Eastbound	RT	1.00	100	1,600	0.002	V/C: 0.941 Lost Time: 0.100 ITS: -0.070 ICU: 0.971 LOS: E
	TH	2.00	610	3,200	0.191 *	
	LT	1.00	250	1,600	0.156	

* - Denotes critical movement

Project Title: Bradley West Project
Intersection: 50 - Duquesne Ave and Jefferson Blvd
Description: Future-Adjusted (2013) Without Project Conditions

Date/Time: AM PEAK HOUR

Thru Lane: 1600 vph N-S Split Phase : N
 Left Lane: 1600 vph E-W Split Phase : N
 Double Lt Penalty: 20 % Last Time (% of cycle) : 10
 ITS: 7 % V/C Round Off (decs.) : 3
 OLA Movements : SBR
 FF Movements :

APPROACH	MVMT	LANES	VOLUME	CAPACITY	V/C	ICU ANALYSIS
Southbound	RT	1.00	160	1,600	0.000	N-S(1): 0.112 * N-S(2): 0.025 * E-W(1): 0.262 * E-W(2): 0.472 * V/C: 0.584 Lost Time: 0.100 ITS: -0.070 ICU: 0.614 LOS: B
	TH	1.00	30	1,600	0.019	
	LT	1.00	170	1,600	0.106 *	
Westbound	RT	1.00	220	1,600	0.084	V/C: 0.584 Lost Time: 0.100 ITS: -0.070 ICU: 0.614 LOS: B
	TH	2.00	1,010	3,200	0.316 *	
	LT	1.00	10	1,600	0.006	
Northbound	RT	1.00	10	1,600	0.003	V/C: 0.584 Lost Time: 0.100 ITS: -0.070 ICU: 0.614 LOS: B
	TH	1.00	10	1,600	0.006 *	
	LT	1.00	10	1,600	0.006	
Eastbound	RT	0.00	10	0	0.000	V/C: 0.584 Lost Time: 0.100 ITS: -0.070 ICU: 0.614 LOS: B
	TH	2.00	810	3,200	0.256	
	LT	1.00	250	1,600	0.156 *	

Date/Time: MD PEAK HOUR

APPROACH	MVMT	LANES	VOLUME	CAPACITY	V/C	ICU ANALYSIS
Southbound	RT	1.00	280	1,600	0.000	N-S(1): 0.107 * N-S(2): 0.025 * E-W(1): 0.266 * E-W(2): 0.360 * V/C: 0.467 Lost Time: 0.100 ITS: -0.070 ICU: 0.497 LOS: A
	TH	1.00	30	1,600	0.019	
	LT	1.00	150	1,600	0.094 *	
Westbound	RT	1.00	150	1,600		

Project Title: Bradley West Project						
Intersection: 55 - El Segundo Blvd and Sepulveda Blvd						
Description: Future-Adjusted (2013) Without Project Conditions						
Date/Time: AM PEAK HOUR						
Thru Lane: 1600 vph		N-S Split Phase : N		E-W Split Phase : N		
Left Lane: 1600 vph		E-W Split Phase : N		E-W Split Phase : N		
Double Lt Penalty: 20 %		Lost Time (% of cycle): 10		V/C Round Off (decs.): 3		
ITS: 0 %		V/C Round Off (decs.): 3		V/C Round Off (decs.): 3		
OLA Movements : FF Movements :						
APPROACH	MVMT	LANES	VOLUME	CAPACITY	V/C	ICU ANALYSIS
Southbound	RT	1.00	130	1,600	0.044	N-S(1): 0.613 * N-S(2): 0.277 * E-W(1): 0.166 * E-W(2): 0.176 * V/C: 0.789 Lost Time: 0.100 ITS: 0.000 ICU: 0.889 LOS: D
	TH	4.00	1,000	6,400	0.156	
	LT	2.00	220	2,560	0.086 *	
Westbound	RT	1.00	230	1,600	0.101 *	V/C: 0.789 Lost Time: 0.100 ITS: 0.000 ICU: 0.889 LOS: D
	TH	2.00	320	3,200	0.100	
	LT	2.00	170	2,560	0.066	
Northbound	RT	0.00	360	0	0.000	V/C: 0.789 Lost Time: 0.100 ITS: 0.000 ICU: 0.889 LOS: D
	TH	4.00	3,010	6,400	0.527 *	
	LT	2.00	310	2,560	0.121	
Eastbound	RT	1.00	190	1,600	0.058	V/C: 0.789 Lost Time: 0.100 ITS: 0.000 ICU: 0.889 LOS: D
	TH	2.00	320	3,200	0.100	
	LT	1.00	120	1,600	0.075 *	
Date/Time: MD PEAK HOUR						
APPROACH	MVMT	LANES	VOLUME	CAPACITY	V/C	ICU ANALYSIS
Southbound	RT	1.00	160	1,600	0.038	N-S(1): 0.382 N-S(2): 0.407 * E-W(1): 0.225 * E-W(2): 0.222 * V/C: 0.733 Lost Time: 0.100 ITS: 0.000 ICU: 0.833 LOS: D
	TH	4.00	1,730	6,400	0.270 *	
	LT	2.00	230	2,560	0.090	
Westbound	RT	1.00	220	1,600	0.093	V/C: 0.733 Lost Time: 0.100 ITS: 0.000 ICU: 0.833 LOS: D
	TH	1.00	310	3,200	0.097	
	LT	2.00	450	2,560	0.176 *	
Northbound	RT	0.00	260	0	0.000	V/C: 0.733 Lost Time: 0.100 ITS: 0.000 ICU: 0.833 LOS: D
	TH	4.00	1,610	6,400	0.292	
	LT	2.00	350	2,560	0.137 *	
Eastbound	RT	1.00	350	1,600	0.150 *	V/C: 0.733 Lost Time: 0.100 ITS: 0.000 ICU: 0.833 LOS: D
	TH	2.00	400	3,200	0.125	
	LT	1.00	200	1,600	0.125	
Date/Time: PM PEAK HOUR						
APPROACH	MVMT	LANES	VOLUME	CAPACITY	V/C	ICU ANALYSIS
Southbound	RT	1.00	120	1,600	0.019	N-S(1): 0.386 N-S(2): 0.518 * E-W(1): 0.389 * E-W(2): 0.233 * V/C: 0.907 Lost Time: 0.100 ITS: 0.000 ICU: 1.007 LOS: F
	TH	4.00	2,690	6,400	0.420 *	
	LT	2.00	250	2,560	0.098	
Westbound	RT	1.00	270	1,600	0.130	V/C: 0.907 Lost Time: 0.100 ITS: 0.000 ICU: 1.007 LOS: F
	TH	2.00	310	3,200	0.097	
	LT	2.00	480	2,560	0.188 *	
Northbound	RT	0.00	200	0	0.000	V/C: 0.907 Lost Time: 0.100 ITS: 0.000 ICU: 1.007 LOS: F
	TH	4.00	1,640	6,400	0.258	
	LT	2.00	250	2,560	0.098 *	
Eastbound	RT	1.00	400	1,600	0.201 *	V/C: 0.907 Lost Time: 0.100 ITS: 0.000 ICU: 1.007 LOS: F
	TH	2.00	500	3,200	0.156	
	LT	1.00	180	1,600	0.113	

* - Denotes critical movement

Project Title: Bradley West Project						
Intersection: 57 - Florence Ave and La Brea Ave						
Description: Future-Adjusted (2013) Without Project Conditions						
Date/Time: AM PEAK HOUR						
Thru Lane: 1600 vph		N-S Split Phase : N		E-W Split Phase : N		
Left Lane: 1600 vph		E-W Split Phase : N		E-W Split Phase : N		
Double Lt Penalty: 20 %		Lost Time (% of cycle): 10		V/C Round Off (decs.): 10		
ITS: 0 %		V/C Round Off (decs.): 10		V/C Round Off (decs.): 3		
OLA Movements : FF Movements :						
APPROACH	MVMT	LANES	VOLUME	CAPACITY	V/C	ICU ANALYSIS
Southbound	RT	1.00	120	1,600	0.047	N-S(1): 0.325 * N-S(2): 0.163 E-W(1): 0.226 * E-W(2): 0.375 * V/C: 0.700 Lost Time: 0.100 ITS: 0.000 ICU: 0.800 LOS: C
	TH	2.00	460	3,200	0.144	
	LT	1.00	80	1,600	0.050 *	
Westbound	RT	0.00	110	0	0.000	V/C: 0.700 Lost Time: 0.100 ITS: 0.000 ICU: 0.800 LOS: C
	TH	2.00	910	3,200	0.319 *	
	LT	1.00	140	1,600	0.088	
Northbound	RT	1.00	30	1,600	0.000	V/C: 0.700 Lost Time: 0.100 ITS: 0.000 ICU: 0.800 LOS: C
	TH	2.00	880	3,200	0.275 *	
	LT	1.00	30	1,600	0.019	
Eastbound	RT	0.00	30	0	0.000	V/C: 0.700 Lost Time: 0.100 ITS: 0.000 ICU: 0.800 LOS: C
	TH	2.00	410	3,200	0.138	
	LT	1.00	90	1,600	0.056 *	
Date/Time: MD PEAK HOUR						
APPROACH	MVMT	LANES	VOLUME	CAPACITY	V/C	ICU ANALYSIS
Southbound	RT	1.00	130	1,600	0.050	N-S(1): 0.316 * N-S(2): 0.244 E-W(1): 0.225 * E-W(2): 0.222 * V/C: 0.541 Lost Time: 0.100 ITS: 0.000 ICU: 0.641 LOS: B
	TH	2.00	720	3,200	0.225	
	LT	1.00	180	1,600	0.113 *	
Westbound	RT	0.00	180	0	0.000	V/C: 0.541 Lost Time: 0.100 ITS: 0.000 ICU: 0.641 LOS: B
	TH	2.00	330	3,200	0.159	
	LT	1.00	110	1,600	0.069 *	
Northbound	RT	1.00	160	1,600	0.066	V/C: 0.541 Lost Time: 0.100 ITS: 0.000 ICU: 0.641 LOS: B
	TH	2.00	650	3,200	0.203 *	
	LT	1.00	30	1,600	0.019	
Eastbound	RT	0.00	60	0	0.000	V/C: 0.541 Lost Time: 0.100 ITS: 0.000 ICU: 0.641 LOS: B
	TH	2.00	440	3,200	0.156 *	
	LT	1.00	100	1,600	0.063	
Date/Time: PM PEAK HOUR						
APPROACH	MVMT	LANES	VOLUME	CAPACITY	V/C	ICU ANALYSIS
Southbound	RT	1.00	80	1,600	0.003	N-S(1): 0.391 * N-S(2): 0.369 E-W(1): 0.506 * E-W(2): 0.313 * V/C: 0.897 Lost Time: 0.100 ITS: 0.000 ICU: 0.997 LOS: E
	TH	2.00	1,140	3,200	0.356	
	LT	1.00	220	1,600	0.138 *	
Westbound	RT	0.00	170	0	0.000	V/C: 0.897 Lost Time: 0.100 ITS: 0.000 ICU: 0.997 LOS: E
	TH	2.00	530	3,200	0.219	
	LT	1.00	120	1,600	0.075 *	
Northbound	RT	1.00	110	1,600	0.031	V/C: 0.897 Lost Time: 0.100 ITS: 0.000 ICU: 0.997 LOS: E
	TH	2.00	610	3,200	0.253 *	
	LT	1.00	20	1,600	0.013	
Eastbound	RT	0.00	50	0	0.000	V/C: 0.897 Lost Time: 0.100 ITS: 0.000 ICU: 0.997 LOS: E
	TH	2.00	1,330	3,200	0.431 *	
	LT	1.00	150	1,600	0.094	

* - Denotes critical movement

Project Title: Bradley West Project						
Intersection: 58 - Florence Ave and La Cienega Blvd						
Description: Future-Adjusted (2013) Without Project Conditions						
Date/Time: AM PEAK HOUR						
Thru Lane: 1600 vph		N-S Split Phase : Y		E-W Split Phase : N		
Left Lane: 1600 vph		E-W Split Phase : N		E-W Split Phase : N		
Double Lt Penalty: 20 %		Lost Time (% of cycle): 10		V/C Round Off (decs.): 10		
ITS: 0 %		V/C Round Off (decs.): 10		V/C Round Off (decs.): 3		
OLA Movements : FF Movements :						
APPROACH	MVMT	LANES	VOLUME	CAPACITY	V/C	ICU ANALYSIS
Southbound	RT	1.00	260	1,600	0.125	N-S(1): 0.397 * N-S(2): 0.000 E-W(1): 0.276 * E-W(2): 0.356 * V/C: 0.753 Lost Time: 0.100 ITS: 0.000 ICU: 0.853 LOS: D
	TH	1.86	1,590	2,991	0.198	
	LT	1.14	360	1,455	0.247 *	
Westbound	RT	0.00	60	0	0.000	V/C: 0.753 Lost Time: 0.100 ITS: 0.000 ICU: 0.853 LOS: D
	TH	2.00	840	3,200	0.281 *	
	LT	1.00	220	1,600	0.097	
Northbound	RT	0.00	80	0	0.000	V/C: 0.753 Lost Time: 0.100 ITS: 0.000 ICU: 0.853 LOS: D
	TH	2.00	400	3,200	0.150 *	
	LT	1.00	40	1,600	0.025	
Eastbound	RT	0.00	40	0	0.000	V/C: 0.753 Lost Time: 0.100 ITS: 0.000 ICU: 0.853 LOS: D
	TH	2.00	400	3,200	0.138	
	LT	1.00	120	1,600	0.075 *	
Date/Time: MD PEAK HOUR						
APPROACH	MVMT	LANES	VOLUME	CAPACITY	V/C	ICU ANALYSIS
Southbound	RT	1.00	260	1,600	0.100	N-S(1): 0.393 * N-S(2): 0.000 E-W(1): 0.288 * E-W(2): 0.281 * V/C: 0.681 Lost Time: 0.100 ITS: 0.000 ICU: 0.781 LOS: C
	TH	1.93	670	3,092	0.217	
	LT	1.07	370	1,366	0.271 *	
Westbound	RT	0.00	60	0	0.000	V/C: 0.681 Lost Time: 0.100 ITS: 0.000 ICU: 0.781 LOS: C
	TH	2.00	440	3,200	0.156	
	LT	1.00	240	1,600	0.150 *	
Northbound	RT	0.00	80	0	0.000	V/C: 0.681 Lost Time: 0.100 ITS: 0.000 ICU: 0.781 LOS: C
	TH	2.00	310	3,200	0.122 *	
	LT	1.00	20	1,600	0.013	
Eastbound	RT	0.00	50	0	0.000	V/C: 0.681 Lost Time: 0.100 ITS: 0.000 ICU: 0.781 LOS: C
	TH	2.00	390	3,200	0.138 *	
	LT	1.00	200	1,600	0.125	
Date/Time: PM PEAK HOUR						
APPROACH	MVMT	LANES	VOLUME	CAPACITY	V/C	ICU ANALYSIS
Southbound	RT	1.00	270	1,600	0.109	N-S(1): 0.623 * N-S(2): 0.000 E-W(1): 0.365 * E-W(2): 0.260 * V/C: 0.988 Lost Time: 0.100 ITS: 0.000 ICU: 1.088 LOS: F
	TH	1.96	1,160	3,128	0.371	
	LT	1.04	620	1,338	0.464 *	
Westbound	RT	0.00	50	0	0.000	V/C: 0.988 Lost Time: 0.100 ITS: 0.000 ICU: 1.088 LOS: F
	TH	2.00	440	3,200	0.156	
	LT	1.00	240	1,600	0.150 *	
Northbound	RT	0.00	80	0	0.000	V/C: 0.988 Lost Time: 0.100 ITS: 0.000 ICU: 1.088 LOS: F
	TH	2.00	310	3,200	0.122 *	
	LT	1.00	20	1,600	0.013	
Eastbound	RT	0.00	40	0	0.000	V/C: 0.988 Lost Time: 0.100 ITS: 0.000 ICU: 1.088 LOS: F
	TH	2.00	630	3,200	0.209 *	
	LT	1.00	190	1,600	0.119	

* - Denotes critical movement

Project Title: Bradley West Project						
Intersection: 60 - Grand Ave and Sepulveda Blvd						
Description: Future-Adjusted (2013) Without Project Conditions						
Date/Time: AM PEAK HOUR						
Thru Lane: 1600 vph		N-S Split Phase : N		E-W Split Phase : N		
Left Lane: 1600 vph		E-W Split Phase : N		E-W Split Phase : N		
Double Lt Penalty: 20 %		Lost Time (% of cycle): 10		V/C Round Off (decs.): 10		
ITS: 0 %		V/C Round Off (decs.): 10		V/C Round Off (decs.): 3		
OLA Movements : FF Movements :						
APPROACH	MVMT	LANES	VOLUME	CAPACITY	V/C	ICU ANALYSIS
Southbound	RT	0.00	160	0	0.000	N-S(1): 0.674 * N-S(2): 0.294 E-W(1): 0.115 * E-W(2): 0.000 V/C: 0.789 Lost Time: 0.100 ITS: 0.000 ICU: 0.889 LOS: D
	TH	4.00	1,290	6,400	0.205	
	LT	1.00	380	1,600	0.238 *	
Westbound	RT	1.00	60	1,600	0.000	V/C: 0.789 Lost Time: 0.100 ITS: 0.000 ICU: 0.889 LOS: D
	TH	2.00	40	3,200	0.013	
	LT	1.00	40	2,560	0.016 *	
Northbound	RT	1.				

Project Title: Bradley West Project
Intersection: 79 - Jefferson Blvd (E/W) and Overland Ave (N/S)
Description: Future-Adjusted (2013) Without Project Conditions

Date/Time: AM PEAK HOUR

Thru Lane: 1600 vph N-S Split Phase : N
 Left Lane: 1600 vph E-W Split Phase : N
 Double Lt Penalty: 20 % Lost Time (% of cycle) : 10
 ITS: 7 % V/C Round Off (decs.) : 3
 OLA Movements : NBR, SBR
 FF Movements :

APPROACH	MVMT	LANES	VOLUME	CAPACITY	V/C	ICU ANALYSIS
Southbound	RT	1.00	250	1,600	0.000	N-S(1): 0.281 * N-S(2): 0.156 E-W(1): 0.266 E-W(2): 0.433 * V/C: 0.714 Lost Time: 0.100 ITS: -0.070 ICU: 0.744 LOS: C
	TH	2.00	400	3,200	0.125	
	LT	1.00	130	1,600	0.081 *	
Westbound	RT	1.00	220	1,600	0.097	V/C: 0.546 Lost Time: 0.100 ITS: -0.070 ICU: 0.883 LOS: D
	TH	2.00	660	3,200	0.206 *	
	LT	2.00	240	2,560	0.094 *	
Northbound	RT	1.00	390	1,600	0.150	N-S(1): 0.210 * N-S(2): 0.182 E-W(1): 0.326 E-W(2): 0.336 * V/C: 0.546 Lost Time: 0.100 ITS: -0.070 ICU: 0.576 LOS: A
	TH	2.00	640	3,200	0.200 *	
	LT	1.00	50	1,600	0.031	
Eastbound	RT	0.00	30	0	0.000	N-S(1): 0.389 * N-S(2): 0.238 E-W(1): 0.448 E-W(2): 0.464 * V/C: 0.853 Lost Time: 0.100 ITS: -0.070 ICU: 0.883 LOS: D
	TH	2.00	520	3,200	0.172 *	
	LT	2.00	580	2,560	0.227 *	

Date/Time: MD PEAK HOUR

APPROACH	MVMT	LANES	VOLUME	CAPACITY	V/C	ICU ANALYSIS
Southbound	RT	1.00	390	1,600	0.048	N-S(1): 0.413 * N-S(2): 0.241 E-W(1): 0.283 * E-W(2): 0.254 V/C: 0.696 Lost Time: 0.100 ITS: -0.070 ICU: 0.726 LOS: C
	TH	2.00	440	3,200	0.138	
	LT	1.00	140	1,600	0.088 *	
Westbound	RT	1.00	240	1,600	0.106	N-S(1): 0.459 * N-S(2): 0.384 E-W(1): 0.421 * E-W(2): 0.334 V/C: 0.880 Lost Time: 0.100 ITS: -0.070 ICU: 0.910 LOS: E
	TH	2.00	450	3,200	0.141 *	
	LT	2.00	290	2,560	0.113	
Northbound	RT	1.00	310	1,600	0.080	N-S(1): 0.289 * N-S(2): 0.223 E-W(1): 0.306 * E-W(2): 0.062 V/C: 0.529 Lost Time: 0.100 ITS: -0.070 ICU: 0.559 LOS: A
	TH	2.00	390	3,200	0.122 *	
	LT	1.00	70	1,600	0.044	
Eastbound	RT	0.00	70	0	0.000	N-S(1): 0.183 N-S(2): 0.304 * E-W(1): 0.303 * E-W(2): 0.113 V/C: 0.607 Lost Time: 0.100 ITS: -0.070 ICU: 0.637 LOS: B
	TH	2.00	610	3,200	0.213	
	LT	2.00	500	2,560	0.195 *	

Date/Time: PM PEAK HOUR

APPROACH	MVMT	LANES	VOLUME	CAPACITY	V/C	ICU ANALYSIS
Southbound	RT	1.00	500	1,600	0.082	N-S(1): 0.288 * N-S(2): 0.323 * E-W(1): 0.231 * E-W(2): 0.076 V/C: 0.554 Lost Time: 0.100 ITS: -0.070 ICU: 0.584 LOS: A
	TH	2.00	760	3,200	0.238	
	LT	1.00	230	1,600	0.144 *	
Westbound	RT	1.00	180	1,600	0.041	N-S(1): 0.665 * N-S(2): 0.344 E-W(1): 0.090 * E-W(2): 0.000 V/C: 0.755 Lost Time: 0.100 ITS: -0.100 ICU: 0.755 LOS: C
	TH	2.00	750	3,200	0.234 *	
	LT	2.00	380	2,560	0.148	
Northbound	RT	1.00	630	1,600	0.245 *	N-S(1): 0.222 * N-S(2): 0.242 E-W(1): 0.082 * E-W(2): 0.000 V/C: 0.807 Lost Time: 0.100 ITS: -0.100 ICU: 0.807 LOS: D
	TH	2.00	660	3,200	0.206	
	LT	1.00	70	1,600	0.044	
Eastbound	RT	0.00	40	0	0.000	N-S(1): 0.725 * N-S(2): 0.242 E-W(1): 0.082 * E-W(2): 0.000 V/C: 0.807 Lost Time: 0.100 ITS: -0.100 ICU: 0.807 LOS: D
	TH	2.00	920	3,200	0.300	
	LT	2.00	590	2,560	0.230 *	

* - Denotes critical movement

Project Title: Bradley West Project
Intersection: 81 - Jefferson Blvd / Playa St and Sepulveda Blvd
Description: Future-Adjusted (2013) Without Project Conditions

Date/Time: AM PEAK HOUR

Thru Lane: 1600 vph N-S Split Phase : N
 Left Lane: 1600 vph E-W Split Phase : N
 Double Lt Penalty: 20 % Lost Time (% of cycle) : 10
 ITS: 7 % V/C Round Off (decs.) : 3
 OLA Movements :
 FF Movements :

APPROACH	MVMT	LANES	VOLUME	CAPACITY	V/C	ICU ANALYSIS
Southbound	RT	2.00	640	3,200	0.108	N-S(1): 0.385 * N-S(2): 0.244 E-W(1): 0.164 E-W(2): 0.297 * V/C: 0.682 Lost Time: 0.100 ITS: -0.070 ICU: 0.712 LOS: C
	TH	2.00	700	3,200	0.219	
	LT	1.00	50	1,600	0.031 *	
Westbound	RT	0.00	180	1,600	0.113 *	N-S(1): 0.413 * N-S(2): 0.241 E-W(1): 0.283 * E-W(2): 0.254 V/C: 0.696 Lost Time: 0.100 ITS: -0.070 ICU: 0.726 LOS: C
	TH	3.00	300	3,200	0.094	
	LT	2.00	180	2,560	0.070	
Northbound	RT	0.00	110	0	0.000	N-S(1): 0.459 * N-S(2): 0.384 E-W(1): 0.421 * E-W(2): 0.334 V/C: 0.880 Lost Time: 0.100 ITS: -0.070 ICU: 0.910 LOS: E
	TH	3.00	1,590	4,800	0.354 *	
	LT	1.00	40	1,600	0.025	
Eastbound	RT	0.00	20	0	0.000	N-S(1): 0.289 * N-S(2): 0.223 E-W(1): 0.306 * E-W(2): 0.062 V/C: 0.529 Lost Time: 0.100 ITS: -0.070 ICU: 0.559 LOS: A
	TH	2.00	280	3,200	0.084	
	LT	2.00	470	2,560	0.184 *	

Date/Time: MD PEAK HOUR

APPROACH	MVMT	LANES	VOLUME	CAPACITY	V/C	ICU ANALYSIS
Southbound	RT	2.00	620	3,200	0.120	N-S(1): 0.413 * N-S(2): 0.241 E-W(1): 0.283 * E-W(2): 0.254 V/C: 0.696 Lost Time: 0.100 ITS: -0.070 ICU: 0.726 LOS: C
	TH	2.00	770	3,200	0.241	
	LT	1.00	160	1,600	0.100 *	
Westbound	RT	0.00	170	1,600	0.106	N-S(1): 0.459 * N-S(2): 0.384 E-W(1): 0.421 * E-W(2): 0.334 V/C: 0.880 Lost Time: 0.100 ITS: -0.070 ICU: 0.910 LOS: E
	TH	2.00	300	3,200	0.094	
	LT	2.00	370	2,560	0.145 *	
Northbound	RT	0.00	140	0	0.000	N-S(1): 0.289 * N-S(2): 0.223 E-W(1): 0.306 * E-W(2): 0.062 V/C: 0.529 Lost Time: 0.100 ITS: -0.070 ICU: 0.559 LOS: A
	TH	3.00	1,360	4,800	0.313 *	
	LT	1.00	80	1,600	0.050	
Eastbound	RT	0.00	20	0	0.000	N-S(1): 0.725 * N-S(2): 0.242 E-W(1): 0.082 * E-W(2): 0.000 V/C: 0.807 Lost Time: 0.100 ITS: -0.100 ICU: 0.807 LOS: D
	TH	2.00	420	3,200	0.138 *	
	LT	2.00	380	2,560	0.148	

Date/Time: PM PEAK HOUR

APPROACH	MVMT	LANES	VOLUME	CAPACITY	V/C	ICU ANALYSIS
Southbound	RT	2.00	540	3,200	0.077	N-S(1): 0.665 * N-S(2): 0.344 E-W(1): 0.090 * E-W(2): 0.000 V/C: 0.755 Lost Time: 0.100 ITS: -0.100 ICU: 0.755 LOS: C
	TH	2.00	1,230	3,200	0.384	
	LT	1.00	100	1,600	0.063 *	
Westbound	RT	0.00	240	1,600	0.150	N-S(1): 0.222 * N-S(2): 0.242 E-W(1): 0.082 * E-W(2): 0.000 V/C: 0.807 Lost Time: 0.100 ITS: -0.100 ICU: 0.807 LOS: D
	TH	3.00	270	3,200	0.084	
	LT	2.00	550	2,560	0.215 *	
Northbound	RT	0.00	170	0	0.000	N-S(1): 0.725 * N-S(2): 0.242 E-W(1): 0.082 * E-W(2): 0.000 V/C: 0.807 Lost Time: 0.100 ITS: -0.100 ICU: 0.807 LOS: D
	TH	3.00	1,720	4,800	0.356 *	
	LT	1.00	70	1,600	0.044	
Eastbound	RT	0.00	20	0	0.000	N-S(1): 0.289 * N-S(2): 0.223 E-W(1): 0.306 * E-W(2): 0.062 V/C: 0.529 Lost Time: 0.100 ITS: -0.070 ICU: 0.559 LOS: A
	TH	2.00	640	3,200	0.206 *	
	LT	2.00	470	2,560	0.184 *	

* - Denotes critical movement

Project Title: Bradley West Project
Intersection: 82 - Jefferson Blvd (E/W) and Stauson Ave (N/S)
Description: Future-Adjusted (2013) Without Project Conditions

Date/Time: AM PEAK HOUR

Thru Lane: 1600 vph N-S Split Phase : N
 Left Lane: 1600 vph E-W Split Phase : N
 Double Lt Penalty: 20 % Lost Time (% of cycle) : 10
 ITS: 7 % V/C Round Off (decs.) : 3
 OLA Movements : NBR
 FF Movements :

APPROACH	MVMT	LANES	VOLUME	CAPACITY	V/C	ICU ANALYSIS
Southbound	RT	0.00	20	0	0.000	N-S(1): 0.167 N-S(2): 0.223 * E-W(1): 0.306 * E-W(2): 0.062 V/C: 0.529 Lost Time: 0.100 ITS: -0.070 ICU: 0.559 LOS: A
	TH	3.00	930	4,800	0.198 *	
	LT	1.00	30	1,600	0.019	
Westbound	RT	0.00	30	0	0.000	N-S(1): 0.183 N-S(2): 0.304 * E-W(1): 0.303 * E-W(2): 0.113 V/C: 0.607 Lost Time: 0.100 ITS: -0.070 ICU: 0.637 LOS: B
	TH	1.00	60	1,600	0.056	
	LT	1.00	400	2,560	0.156 *	
Northbound	RT	1.00	120	1,600	0.000	N-S(1): 0.288 * N-S(2): 0.323 * E-W(1): 0.231 * E-W(2): 0.076 V/C: 0.554 Lost Time: 0.100 ITS: -0.070 ICU: 0.584 LOS: A
	TH	3.00	710	4,800	0.148	
	LT	1.00	40	1,600	0.025 *	
Eastbound	RT	1.00	260	1,600	0.150 *	N-S(1): 0.665 * N-S(2): 0.344 E-W(1): 0.090 * E-W(2): 0.000 V/C: 0.755 Lost Time: 0.100 ITS: -0.100 ICU: 0.755 LOS: C
	TH	1.00	110	1,600	0.069	
	LT	1.00	10	1,600	0.006	

Date/Time: MD PEAK HOUR

APPROACH	MVMT	LANES	VOLUME	CAPACITY	V/C	ICU ANALYSIS
Southbound	RT	0.00	40	0	0.000	N-S(1): 0.183 N-S(2): 0.304 * E-W(1): 0.303 * E-W(2): 0.113 V/C: 0.607 Lost Time: 0.100 ITS: -0.070 ICU: 0.637 LOS: B
	TH	3.00	820	4,800	0.179 *	
	LT	1.00	50	1,600	0.031	
Westbound	RT	0.00	60	0	0.000	N-S(1): 0.288 * N-S(2): 0.323 * E-W(1): 0.231 * E-W(2): 0.076 V/C: 0.554 Lost Time: 0.100 ITS: -0.070 ICU: 0.584 LOS: A
	TH	1.00	90	1,600	0.054 *	
	LT	2.00	470	2,560	0.184 *	
Northbound	RT	1.00	220	1,600	0.000	N-S(1): 0.665 * N-S(2): 0.344 E-W(1): 0.090 * E-W(2): 0.000 V/C: 0.755 Lost Time: 0.100 ITS: -0.100 ICU: 0.755 LOS: C
	TH	3.00	730	4,800	0.152	
	LT	1.00	100	1,600	0.025 *	
Eastbound	RT	1.00	290	1,600	0.119 *	N-S(1): 0.725 * N-S(2): 0.242 E-W(1): 0.082 * E-W(2): 0.000 V/C: 0.807 Lost Time: 0.100 ITS: -0.100 ICU: 0.807 LOS: D
	TH	1.00	40	1,600	0.025	
	LT	1.00	30	1,600	0.019	

Date/Time: PM PEAK HOUR

APPROACH	MVMT	LANES	VOLUME	CAPACITY	V/C	ICU ANALYSIS
Southbound	RT	0.00	40	0	0.000	N-S(1): 0.288 * N-S(2): 0.323 * E-W(1): 0.231 * E-W(2): 0.076 V/C: 0.554 Lost Time: 0.100 ITS: -0.070 ICU: 0.584 LOS: A
	TH	3.00	790	4,800	0.173 *	
	LT	1.00	60	1,600	0.038	
Westbound	RT	0.00	50	0	0.000	N-S(1): 0.665 * N-S(2): 0.344 E-W(1): 0.090 * E-W(2): 0.000 V/C: 0.755 Lost Time: 0.100 ITS: -0.100 ICU: 0.755 LOS: C
	TH	1.00	90	1,600	0.054 *	
	LT	2.00	400	2,560	0.156 *	
Northbound	RT	1.00	240	1,600	0.000	N-S(1): 0.222 * N-S(2): 0.242 E-W(1): 0.082 * E-W(2): 0.000 V/C: 0.807 Lost Time: 0.100 ITS: -0.100 ICU: 0.807 LOS: D
	TH	3.00	1,200	4,800	0.250	
	LT	1.00	240	1,600	0.150 *	
Eastbound	RT	1.00	240	1,600	0.075 *	N-S(1): 0.725 * N-S(2): 0.242 E-W(1): 0.082 * E-W(2): 0.000 V/C: 0.807 Lost Time: 0.100 ITS: -0.100 ICU: 0.807 LOS: D
	TH	1.00	70	1,600	0.044	
	LT	1.00	20	1,600	0.013	

* - Denotes critical movement

Project Title: Bradley West Project
Intersection: 112 - Lincoln Blvd and SR-90
Description: Future-Adjusted (2013) Without Project Conditions

Project Title: Bradley West Project		Intersection: 117 - Mariposa Ave and Sepulveda Blvd		Description: Future-Adjusted (2013) Without Project Conditions		
Date/Time: AM PEAK HOUR						
Thru Lane:	1600 vph	N-S Split Phase :	N			
Left Lane:	1600 vph	E-W Split Phase :	N			
Double Lt Penalty:	20 %	Lost Time (% of cycle):	10			
ITS:	0 %	V/C Round Off (decs.):	3			
OLA Movements :						
FF Movements:						
APPROACH	MVMT	LANES	VOLUME	CAPACITY	V/C	ICU ANALYSIS
Southbound	RT	0.00	90	0	0.000	N-S(1): 0.572 *
	TH	4.00	1,920	6,400	0.314	N-S(2): 0.377
	LT	2.00	360	2,560	0.141 *	E-W(1): 0.157 *
Westbound	RT	1.00	150	1,600	0.023	E-W(2): 0.107
	TH	1.00	60	1,600	0.038	V/C: 0.729
	LT	1.00	60	1,600	0.038 *	Lost Time: 0.100
Northbound	RT	1.00	720	1,600	0.431 *	ITS: 0.000
	TH	4.00	2,130	6,400	0.333	ICU: 0.829
	LT	1.00	100	1,600	0.063	LOS: D
Eastbound	RT	0.00	60	0	0.000	
	TH	1.00	150	1,600	0.094	
	LT	1.00	110	1,600	0.069	
Date/Time: MD PEAK HOUR						
APPROACH	MVMT	LANES	VOLUME	CAPACITY	V/C	ICU ANALYSIS
Southbound	RT	0.00	100	0	0.000	N-S(1): 0.431 *
	TH	4.00	1,710	6,400	0.283	N-S(2): 0.346
	LT	2.00	320	2,560	0.125 *	E-W(1): 0.238 *
Westbound	RT	1.00	200	1,600	0.063	E-W(2): 0.163
	TH	1.00	150	1,600	0.094	V/C: 0.669
	LT	1.00	180	1,600	0.113 *	Lost Time: 0.100
Northbound	RT	1.00	150	1,600	0.038	ITS: 0.000
	TH	4.00	1,960	6,400	0.306 *	ICU: 0.769
	LT	1.00	100	1,600	0.063	LOS: C
Eastbound	RT	0.00	60	0	0.000	
	TH	1.00	140	1,600	0.125 *	
	LT	1.00	110	1,600	0.069	
Date/Time: PM PEAK HOUR						
APPROACH	MVMT	LANES	VOLUME	CAPACITY	V/C	ICU ANALYSIS
Southbound	RT	0.00	120	0	0.000	N-S(1): 0.463 *
	TH	4.00	2,230	6,400	0.367	N-S(2): 0.436
	LT	2.00	260	2,560	0.102 *	E-W(1): 0.281 *
Westbound	RT	1.00	300	1,600	0.137 *	E-W(2): 0.212
	TH	1.00	200	1,600	0.125	V/C: 0.744
	LT	1.00	250	1,600	0.156 *	Lost Time: 0.100
Northbound	RT	1.00	140	1,600	0.089	ITS: 0.000
	TH	4.00	2,310	6,400	0.361 *	ICU: 0.844
	LT	1.00	110	1,600	0.069	LOS: D
Eastbound	RT	0.00	60	0	0.000	
	TH	1.00	140	1,600	0.125 *	
	LT	1.00	120	1,600	0.075	

* - Denotes critical movement

Project Title: Bradley West Project		Intersection: 125 - Rosecrans Ave and Sepulveda Blvd		Description: Future-Adjusted (2013) Without Project Conditions		
Date/Time: AM PEAK HOUR						
Thru Lane:	1600 vph	N-S Split Phase :	N			
Left Lane:	1600 vph	E-W Split Phase :	N			
Double Lt Penalty:	20 %	Lost Time (% of cycle):	10			
ITS:	0 %	V/C Round Off (decs.):	3			
OLA Movements :	NBR					
FF Movements:	WBR					
APPROACH	MVMT	LANES	VOLUME	CAPACITY	V/C	ICU ANALYSIS
Southbound	RT	1.00	100	1,600	0.002	N-S(1): 0.795 *
	TH	3.00	1,100	4,800	0.229	N-S(2): 0.331
	LT	2.00	410	2,560	0.160 *	E-W(1): 0.219 *
Westbound	RT	1.00	240	1,600	0.000	E-W(2): 0.218
	TH	2.00	310	3,200	0.097	V/C: 1.014
	LT	2.00	260	2,560	0.102 *	Lost Time: 0.100
Northbound	RT	1.00	580	1,600	0.261	ITS: 0.000
	TH	3.00	3,050	4,800	0.635 *	ICU: 1.114
	LT	2.00	260	2,560	0.102	LOS: F
Eastbound	RT	1.00	130	1,600	0.030	
	TH	3.00	560	4,800	0.117 *	
	LT	2.00	310	2,560	0.121	
Date/Time: MD PEAK HOUR						
APPROACH	MVMT	LANES	VOLUME	CAPACITY	V/C	ICU ANALYSIS
Southbound	RT	1.00	120	1,600	0.032	N-S(1): 0.524 *
	TH	3.00	1,590	4,800	0.331	N-S(2): 0.401
	LT	2.00	470	2,560	0.184 *	E-W(1): 0.272 *
Westbound	RT	1.00	320	1,600	0.000	E-W(2): 0.202
	TH	1.00	370	3,200	0.116	V/C: 0.796
	LT	2.00	470	2,560	0.184 *	Lost Time: 0.100
Northbound	RT	1.00	410	1,600	0.073	ITS: 0.000
	TH	3.00	1,630	4,800	0.340 *	ICU: 0.896
	LT	2.00	160	2,560	0.070	LOS: D
Eastbound	RT	1.00	160	1,600	0.065	
	TH	3.00	420	4,800	0.088 *	
	LT	2.00	220	2,560	0.086	
Date/Time: PM PEAK HOUR						
APPROACH	MVMT	LANES	VOLUME	CAPACITY	V/C	ICU ANALYSIS
Southbound	RT	1.00	200	1,600	0.082	N-S(1): 0.428
	TH	3.00	2,580	4,800	0.538 *	N-S(2): 0.647 *
	LT	2.00	370	2,560	0.145	E-W(1): 0.297 *
Westbound	RT	1.00	290	1,600	0.000	E-W(2): 0.189
	TH	2.00	370	3,200	0.116	V/C: 0.944
	LT	2.00	470	2,560	0.184 *	Lost Time: 0.100
Northbound	RT	1.00	390	1,600	0.048	ITS: 0.000
	TH	3.00	1,360	4,800	0.283	ICU: 1.044
	LT	2.00	280	2,560	0.109 *	LOS: F
Eastbound	RT	1.00	190	1,600	0.064	
	TH	3.00	490	4,800	0.102 *	
	LT	2.00	220	2,560	0.086	

* - Denotes critical movement

Project Title: Bradley West Project		Intersection: 126 - Sawtelle Blvd (E/W) and Sepulveda Blvd (N/S)		Description: Future-Adjusted (2013) Without Project Conditions		
Date/Time: AM PEAK HOUR						
Thru Lane:	1600 vph	N-S Split Phase :	N			
Left Lane:	1600 vph	E-W Split Phase :	N			
Double Lt Penalty:	20 %	Lost Time (% of cycle):	10			
ITS:	7 %	V/C Round Off (decs.):	3			
OLA Movements :						
FF Movements:						
APPROACH	MVMT	LANES	VOLUME	CAPACITY	V/C	ICU ANALYSIS
Southbound	RT	0.00	60	0	0.000	N-S(1): 0.364 *
	TH	3.00	1,140	4,800	0.250	N-S(2): 0.350
	LT	1.00	30	1,600	0.019 *	E-W(1): 0.063
Westbound	RT	0.00	50	0	0.000	E-W(2): 0.109 *
	TH	2.00	60	3,200	0.034 *	V/C: 0.473
	LT	1.00	90	1,600	0.056	Lost Time: 0.100
Northbound	RT	0.00	40	0	0.000	ITS: -0.070
	TH	4.00	2,170	6,400	0.345 *	ICU: 0.503
	LT	1.00	160	1,600	0.100	LOS: A
Eastbound	RT	1.00	90	1,600	0.006	
	TH	2.00	80	3,200	0.025	
	LT	1.00	120	1,600	0.075 *	
Date/Time: MD PEAK HOUR						
APPROACH	MVMT	LANES	VOLUME	CAPACITY	V/C	ICU ANALYSIS
Southbound	RT	0.00	80	0	0.000	N-S(1): 0.333
	TH	3.00	1,230	4,800	0.273 *	N-S(2): 0.354 *
	LT	1.00	100	1,600	0.063	E-W(1): 0.078
Westbound	RT	0.00	180	1,600	0.113 *	E-W(2): 0.213 *
	TH	2.00	90	1,600	0.056	V/C: 0.567
	LT	1.00	50	1,600	0.031	Lost Time: 0.100
Northbound	RT	0.00	110	0	0.000	ITS: -0.070
	TH	4.00	1,620	6,400	0.270	ICU: 0.597
	LT	1.00	130	1,600	0.081 *	LOS: A
Eastbound	RT	1.00	140	1,600	0.047	
	TH	2.00	110	3,200	0.034	
	LT	1.00	160	1,600	0.100 *	
Date/Time: PM PEAK HOUR						
APPROACH	MVMT	LANES	VOLUME	CAPACITY	V/C	ICU ANALYSIS
Southbound	RT	0.00	150	0	0.000	N-S(1): 0.421
	TH	3.00	1,570	4,800	0.358 *	N-S(2): 0.464 *
	LT	1.00	100	1,600	0.063	E-W(1): 0.172
Westbound	RT	0.00	190	0	0.000	E-W(2): 0.194 *
	TH	2.00	130	3,200	0.081 *	V/C: 0.658
	LT	1.00	110	1,600	0.069	Lost Time: 0.100
Northbound	RT	0.00	110	0	0.000	ITS: -0.070
	TH	4.00	2,180	6,400	0.358	ICU: 0.688
	LT	1.00	170	1,600	0.106 *	LOS: B
Eastbound	RT	1.00	250	1,600	0.103	
	TH	2.00	190	3,200	0.059	
	LT	1.00	180	1,600	0.113 *	

* - Denotes critical movement

Project Title: Bradley West Project		Intersection: 130 - Sepulveda Blvd and Slauson Avenue		Description: Future-Adjusted (2013) Without Project Conditions		
Date/Time: AM PEAK HOUR						
Thru Lane:	1600 vph	N-S Split Phase :	N			
Left Lane:	1600 vph	E-W Split Phase :	N			
Double Lt Penalty:	20 %	Lost Time (% of cycle):	10			
ITS:	7 %	V/C Round Off (decs.):	3			
OLA Movements :	EBR					
FF Movements:						
APPROACH	MVMT	LANES	VOLUME	CAPACITY	V/C	ICU ANALYSIS
Southbound	RT	0.00	30	0	0.000	N-S(1): 0.403 *
	TH	2.00	690	3,200	0.225	N-S(2): 0.303
	LT	2.00	120	2,560	0.047 *	E-W(1): 0.087
Westbound	RT	1.00	220	1,600	0.114 *	E-W(2): 0.133 *
	TH	2.00	300	3,200	0.094	V/C: 0.536
	LT	1.00	110	2,560	0.042	Lost Time: 0.100
Northbound	RT	0.00	150	0	0.000	ITS: -0.070
	TH	3.00	1,560	4,800	0.356 *	ICU: 0.566
	LT	2.00	200	2,560	0.078	LOS: A
Eastbound	RT	1.00	160	1,600	0.022	
	TH	2.00	140	3,200	0.044	
	LT	1.00	30	1,600	0.019 *	
Date/Time: MD PEAK HOUR						
APPROACH	MVMT	LANES	VOLUME	CAPACITY	V/C	ICU ANALYSIS
Southbound	RT	0.00	70	0	0.000	N-S(1): 0.414
	TH	2.00	860	3,200	0.291 *	N-S(2): 0.416 *
	LT	2.00	330	2,560	0.129	E-W(1): 0.150
Westbound	RT	1.00	270	1,600	0.104 *	E-W(2): 0.198 *
	TH	2.00	320	3,200	0.100	V/C: 0.614
	LT	2.00	200	2,560	0.078	Lost Time: 0.100
Northbound	RT	0.00	230	0	0.000	ITS: -0.070
	TH	3.00	1,140	4,800	0.285	ICU: 0.644
	LT	2.00	300	2,560	0.125 *	LOS: B
Eastbound	RT	1.00	100	1,600		

Project Title: Bradley West Project Intersection: 147 - Century Boulevard and Crenshaw Boulevard Description: Future-Adjusted (2013) Without Project Conditions						
Date/Time: AM PEAK HOUR						
Thru Lane: 1600 vph Left Lane: 1600 vph Double Lt Penalty: 20 % ITS: 0 % OLA Movements : FF Movements:	N-S Split Phase : N E-W Split Phase : N Lost Time (% of cycle) : 10 V/C Round Off (decs.) : 3					
APPROACH	MVMT	LANES	VOLUME	CAPACITY	V/C	ICU ANALYSIS
Southbound	RT	0.00	110	0	0.000	N-S(1): 0.258 * N-S(2): 0.300 * E-W(1): 0.190 E-W(2): 0.259 * V/C: 0.559 Lost Time: 0.100 ITS: 0.000 ICU: 0.659 LOS: B
	TH	3.00	750	4,900	0.151 *	
	LT	1.00	120	1,600	0.075	
Westbound	RT	0.00	100	0	0.000	V/C: 0.559 Lost Time: 0.100 ITS: 0.000 ICU: 0.659 LOS: B
	TH	3.00	840	4,800	0.196 *	
	LT	1.00	110	1,600	0.069	
Northbound	RT	0.00	60	0	0.000	V/C: 0.559 Lost Time: 0.100 ITS: 0.000 ICU: 0.659 LOS: B
	TH	3.00	820	4,800	0.183	
	LT	1.00	190	1,600	0.119 *	
Eastbound	RT	0.00	110	0	0.000	V/C: 0.559 Lost Time: 0.100 ITS: 0.000 ICU: 0.659 LOS: B
	TH	3.00	470	4,800	0.121	
	LT	1.00	100	1,600	0.063 *	
Date/Time: MD PEAK HOUR						
APPROACH	MVMT	LANES	VOLUME	CAPACITY	V/C	ICU ANALYSIS
Southbound	RT	0.00	190	0	0.000	N-S(1): 0.219 N-S(2): 0.346 * E-W(1): 0.269 E-W(2): 0.276 * V/C: 0.622 Lost Time: 0.100 ITS: 0.000 ICU: 0.722 LOS: C
	TH	3.00	630	4,800	0.171 *	
	LT	1.00	90	1,600	0.056	
Westbound	RT	0.00	70	0	0.000	V/C: 0.622 Lost Time: 0.100 ITS: 0.000 ICU: 0.722 LOS: C
	TH	3.00	710	4,800	0.163 *	
	LT	1.00	100	1,600	0.063	
Northbound	RT	0.00	70	0	0.000	V/C: 0.622 Lost Time: 0.100 ITS: 0.000 ICU: 0.722 LOS: C
	TH	3.00	710	4,800	0.163	
	LT	1.00	200	1,600	0.125 *	
Eastbound	RT	0.00	260	0	0.000	V/C: 0.622 Lost Time: 0.100 ITS: 0.000 ICU: 0.722 LOS: C
	TH	3.00	730	4,800	0.206	
	LT	1.00	180	1,600	0.113 *	
Date/Time: PM PEAK HOUR						
APPROACH	MVMT	LANES	VOLUME	CAPACITY	V/C	ICU ANALYSIS
Southbound	RT	0.00	190	0	0.000	N-S(1): 0.336 N-S(2): 0.407 * E-W(1): 0.369 * E-W(2): 0.325 V/C: 0.776 Lost Time: 0.100 ITS: 0.000 ICU: 0.876 LOS: D
	TH	3.00	950	4,800	0.238 *	
	LT	1.00	230	1,600	0.144	
Westbound	RT	0.00	90	0	0.000	V/C: 0.776 Lost Time: 0.100 ITS: 0.000 ICU: 0.876 LOS: D
	TH	3.00	870	4,800	0.200	
	LT	1.00	120	1,600	0.075 *	
Northbound	RT	0.00	120	0	0.000	V/C: 0.776 Lost Time: 0.100 ITS: 0.000 ICU: 0.876 LOS: D
	TH	3.00	800	4,800	0.192	
	LT	1.00	270	1,600	0.169 *	
Eastbound	RT	0.00	270	0	0.000	V/C: 0.776 Lost Time: 0.100 ITS: 0.000 ICU: 0.876 LOS: D
	TH	3.00	1,140	4,800	0.294 *	
	LT	1.00	200	1,600	0.125	

* - Denotes critical movement

Project Title: Bradley West Project Intersection: 162 - Manhattan Beach Blvd and Sepulveda Blvd Description: Future-Adjusted (2013) Without Project Conditions						
Date/Time: AM PEAK HOUR						
Thru Lane: 1600 vph Left Lane: 1600 vph Double Lt Penalty: 20 % ITS: 0 % OLA Movements : FF Movements:	N-S Split Phase : N E-W Split Phase : N Lost Time (% of cycle) : 10 V/C Round Off (decs.) : 3					
APPROACH	MVMT	LANES	VOLUME	CAPACITY	V/C	ICU ANALYSIS
Southbound	RT	0.00	140	0	0.000	N-S(1): 0.718 * N-S(2): 0.277 E-W(1): 0.266 E-W(2): 0.307 * V/C: 1.025 Lost Time: 0.100 ITS: 0.000 ICU: 1.125 LOS: F
	TH	3.00	650	4,900	0.298	
	LT	2.00	90	2,560	0.035 *	
Westbound	RT	1.00	220	1,600	0.102	V/C: 1.025 Lost Time: 0.100 ITS: 0.000 ICU: 1.125 LOS: F
	TH	2.00	620	3,200	0.194 *	
	LT	1.00	140	1,600	0.088	
Northbound	RT	0.00	110	0	0.000	V/C: 1.025 Lost Time: 0.100 ITS: 0.000 ICU: 1.125 LOS: F
	TH	3.00	3,170	4,800	0.683 *	
	LT	1.00	110	1,600	0.069	
Eastbound	RT	1.00	140	1,600	0.053	V/C: 1.025 Lost Time: 0.100 ITS: 0.000 ICU: 1.125 LOS: F
	TH	2.00	570	3,200	0.178	
	LT	1.00	180	1,600	0.113 *	
Date/Time: MD PEAK HOUR						
APPROACH	MVMT	LANES	VOLUME	CAPACITY	V/C	ICU ANALYSIS
Southbound	RT	0.00	160	0	0.000	N-S(1): 0.388 N-S(2): 0.394 * E-W(1): 0.316 E-W(2): 0.325 * V/C: 0.719 Lost Time: 0.100 ITS: 0.000 ICU: 0.819 LOS: D
	TH	3.00	1,310	4,800	0.306 *	
	LT	2.00	140	2,560	0.055	
Westbound	RT	1.00	170	1,600	0.052	V/C: 0.719 Lost Time: 0.100 ITS: 0.000 ICU: 0.819 LOS: D
	TH	2.00	460	3,200	0.150 *	
	LT	1.00	280	1,600	0.175	
Northbound	RT	0.00	170	0	0.000	V/C: 0.719 Lost Time: 0.100 ITS: 0.000 ICU: 0.819 LOS: D
	TH	3.00	1,430	4,800	0.333	
	LT	1.00	140	1,600	0.088	
Eastbound	RT	1.00	180	1,600	0.069	V/C: 0.719 Lost Time: 0.100 ITS: 0.000 ICU: 0.819 LOS: D
	TH	2.00	450	3,200	0.141	
	LT	1.00	280	1,600	0.175 *	
Date/Time: PM PEAK HOUR						
APPROACH	MVMT	LANES	VOLUME	CAPACITY	V/C	ICU ANALYSIS
Southbound	RT	0.00	130	0	0.000	N-S(1): 0.374 N-S(2): 0.675 * E-W(1): 0.376 * E-W(2): 0.331 V/C: 1.051 Lost Time: 0.100 ITS: 0.000 ICU: 1.151 LOS: F
	TH	3.00	2,540	4,800	0.556 *	
	LT	2.00	200	2,560	0.078	
Westbound	RT	1.00	150	1,600	0.016	V/C: 1.051 Lost Time: 0.100 ITS: 0.000 ICU: 1.151 LOS: F
	TH	2.00	660	3,200	0.206	
	LT	1.00	300	1,600	0.188 *	
Northbound	RT	0.00	150	0	0.000	V/C: 1.051 Lost Time: 0.100 ITS: 0.000 ICU: 1.151 LOS: F
	TH	3.00	1,270	4,800	0.296	
	LT	1.00	190	1,600	0.119 *	
Eastbound	RT	1.00	160	1,600	0.041	V/C: 1.051 Lost Time: 0.100 ITS: 0.000 ICU: 1.151 LOS: F
	TH	2.00	600	3,200	0.188 *	
	LT	1.00	200	1,600	0.125	

* - Denotes critical movement

INTERSECTION DATA SUMMARY SHEET

N/S: W/E: I/S No:

AM/PM: Comments:

COUNT DATE: STUDY DATE: GROWTH FACTOR:

Volume/Lane/Signal Configurations												
NORTHBOUND			SOUTHBOUND			WESTBOUND			EASTBOUND			
EXISTING	LT	TH	RT	LT	TH	RT	LT	TH	RT	LT	TH	RT
	380	630	230	100	850	190	300	670	270	110	300	130
AMBIENT												
RELATED												
PROJECT												
TOTAL	380	630	230	100	850	190	300	670	270	110	300	130
LANE												
SIGNAL	Prot-Fix		Auto	Prot-Fix		Auto	Prot-Fix		Auto	Prot-Fix		Auto

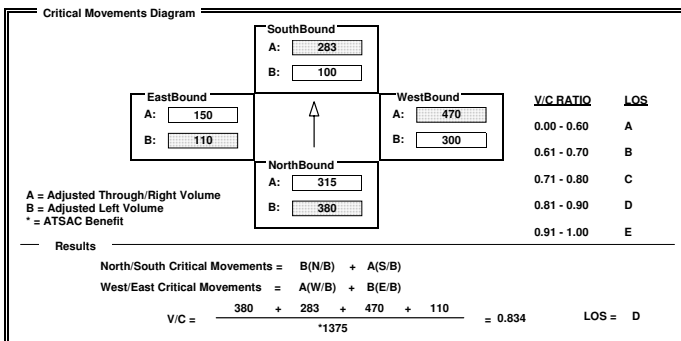

INTERSECTION DATA SUMMARY SHEET

N/S: W/E: I/S No:

AM/PM: Comments:

COUNT DATE: STUDY DATE: GROWTH FACTOR:

Volume/Lane/Signal Configurations												
NORTHBOUND			SOUTHBOUND			WESTBOUND			EASTBOUND			
EXISTING	LT	TH	RT	LT	TH	RT	LT	TH	RT	LT	TH	RT
	30	50	50	320	30	430	80	2830	470	570	1600	30
AMBIENT												
RELATED												
PROJECT												
TOTAL	30	50	50	320	30	430	80	2830	470	570	1600	30
LANE												
SIGNAL	Split		Auto	Split		Auto	Prot-Fix		OLA	Prot-Fix		Auto

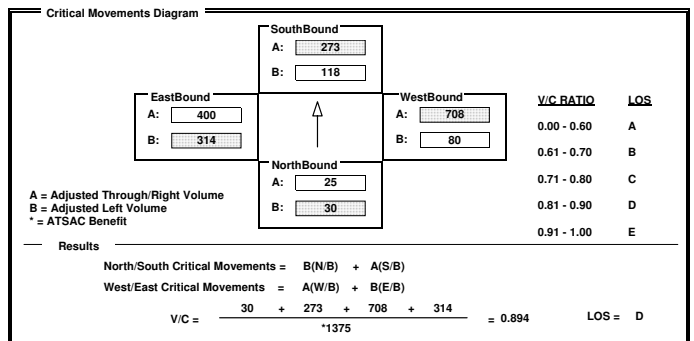

INTERSECTION DATA SUMMARY SHEET

N/S: Airport Blvd W/E: La Tijera Blvd I/S No: 8
AM/PM: AM Comments: Plus Project
COUNT DATE: STUDY DATE: GROWTH FACTOR:

Volume/Lane/Signal Configurations table with columns for Northbound, Southbound, Westbound, Eastbound and rows for Existing, Ambient, Related, Project, Total, Lane, Phasing, RTOR, Signal.

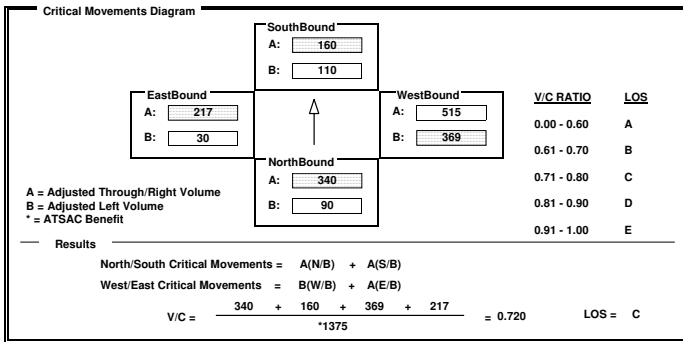

INTERSECTION DATA SUMMARY SHEET

N/S: Airport Blvd W/E: Manchester Ave I/S No: 9
AM/PM: AM Comments: Plus Project
COUNT DATE: STUDY DATE: GROWTH FACTOR:

Volume/Lane/Signal Configurations table with columns for Northbound, Southbound, Westbound, Eastbound and rows for Existing, Ambient, Related, Project, Total, Lane, Phasing, RTOR, Signal.

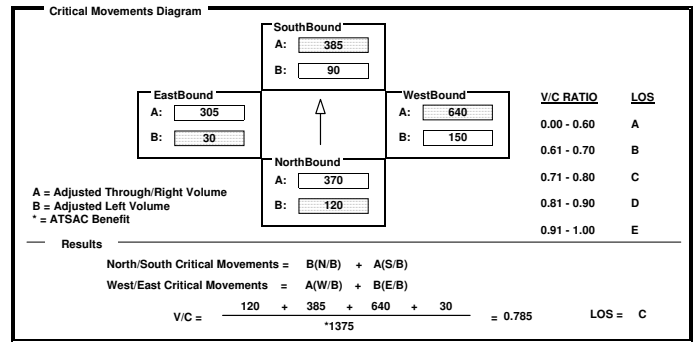

INTERSECTION DATA SUMMARY SHEET

N/S: Aviation Blvd W/E: Arbor Vitae St I/S No: 10
AM/PM: AM Comments: Plus Project
COUNT DATE: STUDY DATE: GROWTH FACTOR:

Volume/Lane/Signal Configurations table with columns for Northbound, Southbound, Westbound, Eastbound and rows for Existing, Ambient, Related, Project, Total, Lane, Phasing, RTOR, Signal.

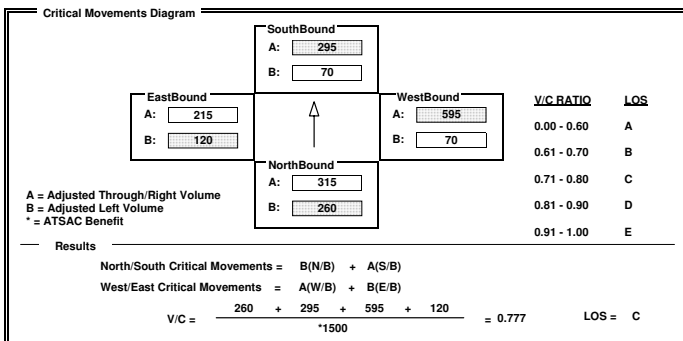

INTERSECTION DATA SUMMARY SHEET

N/S: Aviation Blvd W/E: Century Blvd I/S No: 14
AM/PM: AM Comments: Plus Project
COUNT DATE: STUDY DATE: GROWTH FACTOR:

Volume/Lane/Signal Configurations table with columns for Northbound, Southbound, Westbound, Eastbound and rows for Existing, Ambient, Related, Project, Total, Lane, Phasing, RTOR, Signal.

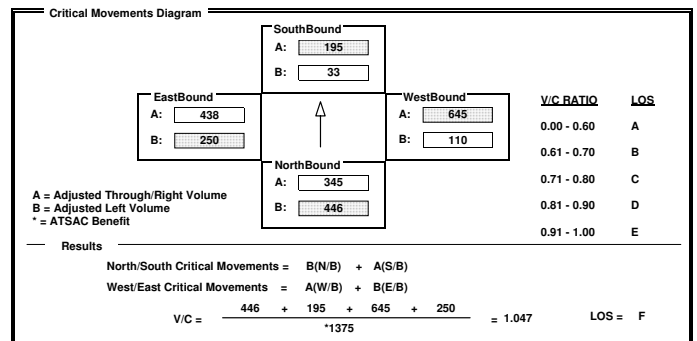

INTERSECTION DATA SUMMARY SHEET

N/S: W/E: I/S No:

AM/PM: Comments:

COUNT DATE: STUDY DATE: GROWTH FACTOR:

Volume/Lane/Signal Configurations

	NORTHBOUND			SOUTHBOUND			WESTBOUND			EASTBOUND		
	LT	TH	RT	LT	TH	RT	LT	TH	RT	LT	TH	RT
EXISTING	520	640	210	270	390	180	310	1220	810	210	550	100
AMBIENT												
RELATED												
PROJECT												
TOTAL	520	640	210	270	390	180	310	1220	810	210	550	100
LANE												
SIGNAL	Prot-Fix		OLA	Prot-Fix		OLA	Prot-Fix		OLA	Prot-Fix		Auto

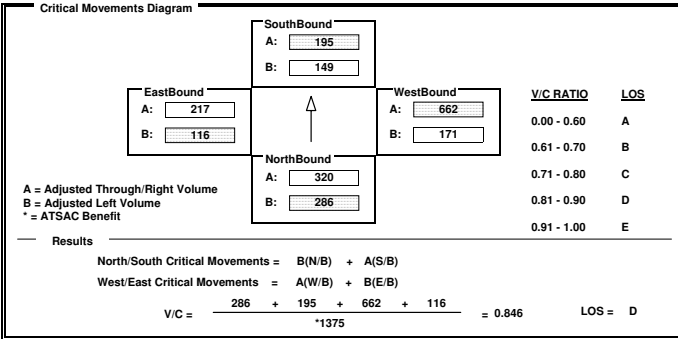

INTERSECTION DATA SUMMARY SHEET

N/S: W/E: I/S No:

AM/PM: Comments:

COUNT DATE: STUDY DATE: GROWTH FACTOR:

Volume/Lane/Signal Configurations

	NORTHBOUND			SOUTHBOUND			WESTBOUND			EASTBOUND		
	LT	TH	RT	LT	TH	RT	LT	TH	RT	LT	TH	RT
EXISTING	90	1530	30	40	1030	200	10	10	20	250	10	320
AMBIENT												
RELATED												
PROJECT												
TOTAL	90	1530	30	40	1030	200	10	10	20	250	10	320
LANE												
SIGNAL	Prot-Fix		Auto	Prot-Fix		Auto	Prot-Fix		Auto	Prot-Fix		Auto

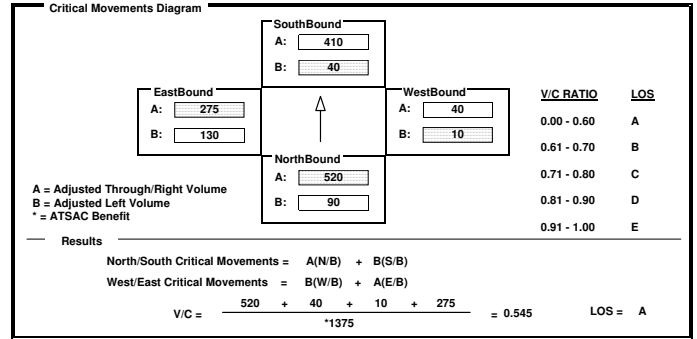

INTERSECTION DATA SUMMARY SHEET

N/S: W/E: I/S No:

AM/PM: Comments:

COUNT DATE: STUDY DATE: GROWTH FACTOR:

Volume/Lane/Signal Configurations

	NORTHBOUND			SOUTHBOUND			WESTBOUND			EASTBOUND		
	LT	TH	RT	LT	TH	RT	LT	TH	RT	LT	TH	RT
EXISTING	0	2170	360	300	1710	0	80	0	100	0	0	0
AMBIENT												
RELATED												
PROJECT												
TOTAL	0	2170	360	300	1710	0	80	0	100	0	0	0
LANE												
SIGNAL	Perm		Auto	Prot-Fix		Auto	Split		Auto	Split		Auto

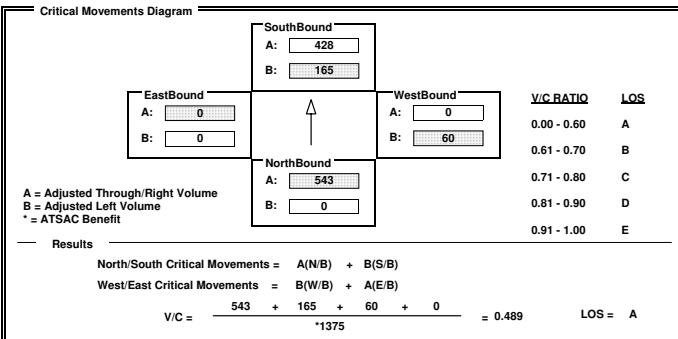

INTERSECTION DATA SUMMARY SHEET

N/S: W/E: I/S No:

AM/PM: Comments:

COUNT DATE: STUDY DATE: GROWTH FACTOR:

Volume/Lane/Signal Configurations

	NORTHBOUND			SOUTHBOUND			WESTBOUND			EASTBOUND		
	LT	TH	RT	LT	TH	RT	LT	TH	RT	LT	TH	RT
EXISTING	290	850	160	30	980	180	310	1190	10	120	410	60
AMBIENT												
RELATED												
PROJECT												
TOTAL	290	850	160	30	980	180	310	1190	10	120	410	60
LANE												
SIGNAL	Prot-Fix		Auto	Prot-Fix		Auto	Prot-Fix		Auto	Prot-Fix		Auto

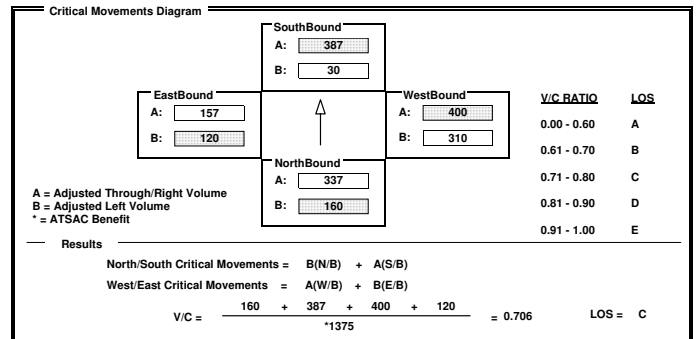

INTERSECTION DATA SUMMARY SHEET

N/S: La Cienega Blvd W/E: Century Blvd I/S No: 36
AM/PM: AM Comments: Plus Project
COUNT DATE: STUDY DATE: GROWTH FACTOR:

Volume/Lane/Signal Configurations table with columns for Northbound, Southbound, Westbound, Eastbound and rows for Existing, Ambient, Related, Project, Total, Lane, Phasing, RTOR, Signal.

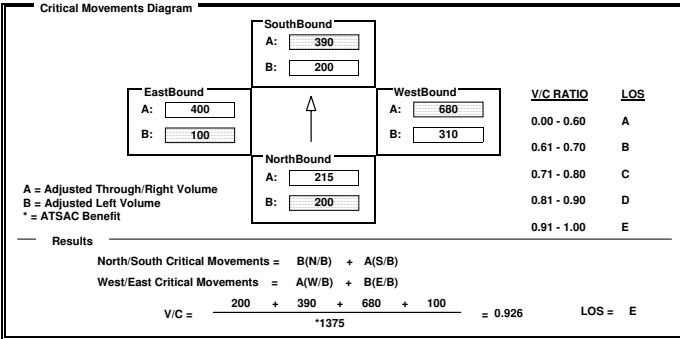

INTERSECTION DATA SUMMARY SHEET

N/S: Sepulveda Blvd W/E: Century Blvd I/S No: 38
AM/PM: AM Comments: Plus Project
COUNT DATE: STUDY DATE: GROWTH FACTOR:

Volume/Lane/Signal Configurations table with columns for Northbound, Southbound, Westbound, Eastbound and rows for Existing, Ambient, Related, Project, Total, Lane, Phasing, RTOR, Signal.

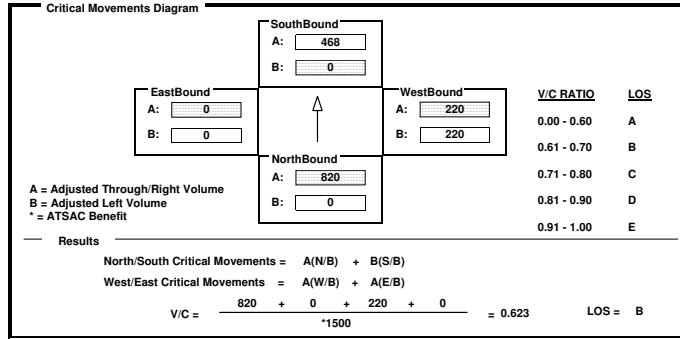

INTERSECTION DATA SUMMARY SHEET

N/S: Douglas St W/E: Imperial Hwy I/S No: 47
AM/PM: AM Comments: Plus Project
COUNT DATE: STUDY DATE: GROWTH FACTOR:

Volume/Lane/Signal Configurations table with columns for Northbound, Southbound, Westbound, Eastbound and rows for Existing, Ambient, Related, Project, Total, Lane, Phasing, RTOR, Signal.

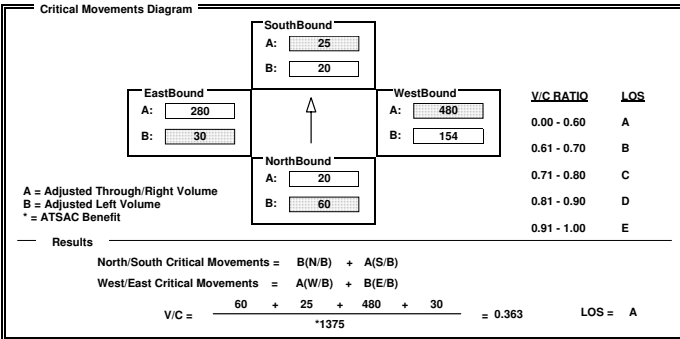

INTERSECTION DATA SUMMARY SHEET

N/S: Lincoln Blvd W/E: Fiji Way I/S No: 56
AM/PM: AM Comments: Plus Project
COUNT DATE: STUDY DATE: GROWTH FACTOR:

Volume/Lane/Signal Configurations table with columns for Northbound, Southbound, Westbound, Eastbound and rows for Existing, Ambient, Related, Project, Total, Lane, Phasing, RTOR, Signal.

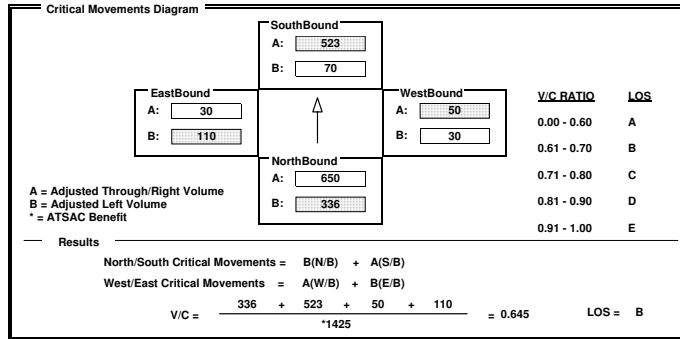

INTERSECTION DATA SUMMARY SHEET

N/S: W/E: I/S No:

AM/PM: Comments:

COUNT DATE: STUDY DATE: GROWTH FACTOR:

Volume/Lane/Signal Configurations

	NORTHBOUND			SOUTHBOUND			WESTBOUND			EASTBOUND		
	LT	TH	RT	LT	TH	RT	LT	TH	RT	LT	TH	RT
EXISTING	0	1970	1300	240	960	0	520	0	340	0	0	0
AMBIENT												
RELATED												
PROJECT												
TOTAL	0	1970	1300	240	960	0	520	0	340	0	0	0
LANE	[Icons]			[Icons]			[Icons]			[Icons]		
SIGNAL	Phasing <none>		RTOR Free	Phasing Prot-Fix		RTOR Auto	Phasing Split		RTOR Auto	Phasing <none>		RTOR <none>

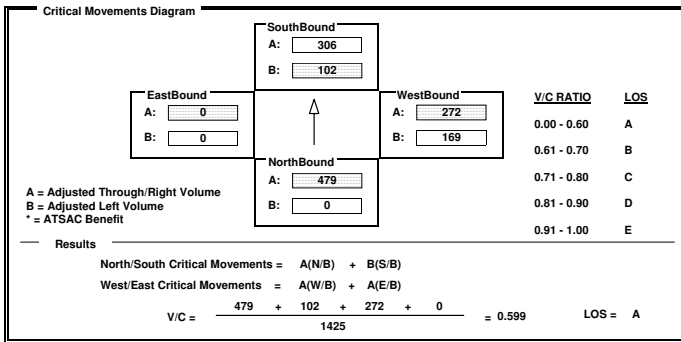

INTERSECTION DATA SUMMARY SHEET

N/S: W/E: I/S No:

AM/PM: Comments:

COUNT DATE: STUDY DATE: GROWTH FACTOR:

Volume/Lane/Signal Configurations

	NORTHBOUND			SOUTHBOUND			WESTBOUND			EASTBOUND		
	LT	TH	RT	LT	TH	RT	LT	TH	RT	LT	TH	RT
EXISTING	90	190	130	80	260	390	230	930	500	340	210	240
AMBIENT												
RELATED												
PROJECT												
TOTAL	90	190	130	80	260	390	230	930	500	340	210	240
LANE	[Icons]			[Icons]			[Icons]			[Icons]		
SIGNAL	Phasing Prot-Fix		RTOR Auto	Phasing Prot-Fix		RTOR Auto	Phasing Prot-Fix		RTOR OLA	Phasing Prot-Fix		RTOR OLA

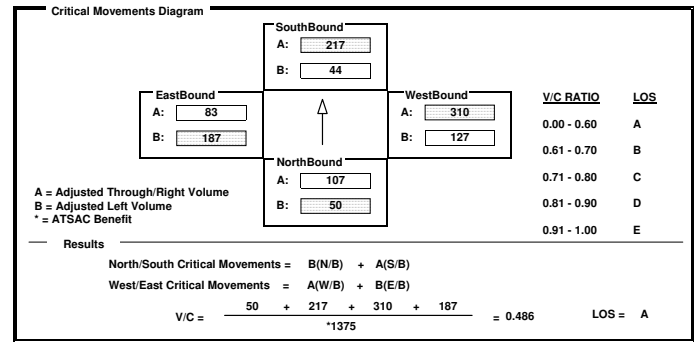

INTERSECTION DATA SUMMARY SHEET

N/S: W/E: I/S No:

AM/PM: Comments:

COUNT DATE: STUDY DATE: GROWTH FACTOR:

Volume/Lane/Signal Configurations

	NORTHBOUND			SOUTHBOUND			WESTBOUND			EASTBOUND		
	LT	TH	RT	LT	TH	RT	LT	TH	RT	LT	TH	RT
EXISTING	140	1760	720	330	2150	400	200	330	380	230	290	220
AMBIENT												
RELATED												
PROJECT												
TOTAL	140	1760	720	330	2150	400	200	330	380	230	290	220
LANE	[Icons]			[Icons]			[Icons]			[Icons]		
SIGNAL	Phasing Prot-Fix		RTOR Auto	Phasing Prot-Fix		RTOR Auto	Phasing Prot-Fix		RTOR OLA	Phasing Prot-Fix		RTOR Auto

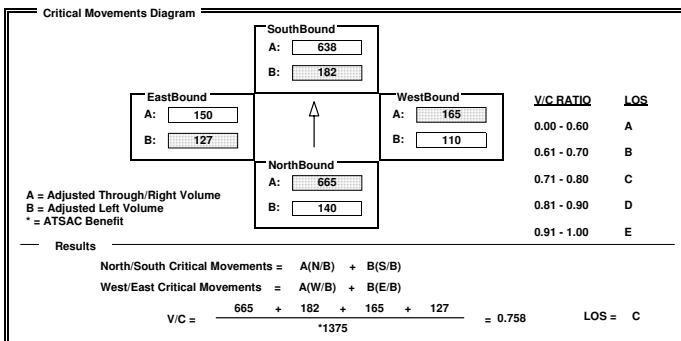

INTERSECTION DATA SUMMARY SHEET

N/S: W/E: I/S No:

AM/PM: Comments:

COUNT DATE: STUDY DATE: GROWTH FACTOR:

Volume/Lane/Signal Configurations

	NORTHBOUND			SOUTHBOUND			WESTBOUND			EASTBOUND		
	LT	TH	RT	LT	TH	RT	LT	TH	RT	LT	TH	RT
EXISTING	20	0	30	400	1280	530	290	920	0	0	570	110
AMBIENT												
RELATED												
PROJECT												
TOTAL	20	0	30	400	1280	530	290	920	0	0	570	110
LANE	[Icons]			[Icons]			[Icons]			[Icons]		
SIGNAL	Phasing Split		RTOR Auto	Phasing Split		RTOR Auto	Phasing Prot-Fix		RTOR Auto	Phasing Perm		RTOR Auto

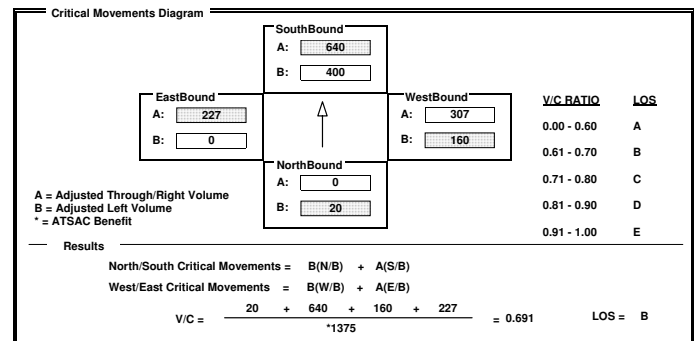

INTERSECTION DATA SUMMARY SHEET

N/S: 105 EB On Ramps W/E: Imperial Hwy I/S No: 74
AM/PM: AM Comments: Plus Project
COUNT DATE: STUDY DATE: GROWTH FACTOR:

Volume/Lane/Signal Configurations table with columns for Northbound, Southbound, Westbound, Eastbound and rows for Existing, Ambient, Related, Project, Total, Lane, and Signal.

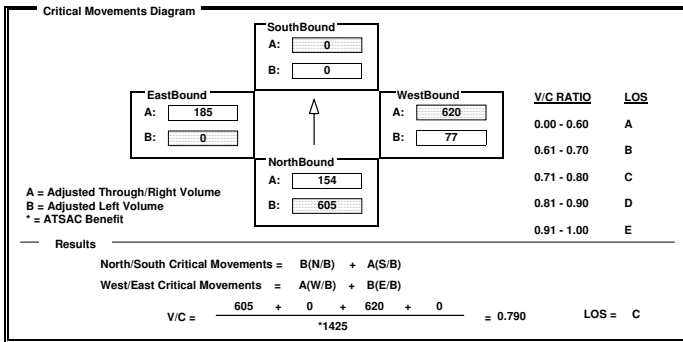

INTERSECTION DATA SUMMARY SHEET

N/S: Lincoln Blvd W/E: Jefferson Blvd I/S No: 78
AM/PM: AM Comments: Plus Project
COUNT DATE: STUDY DATE: GROWTH FACTOR:

Volume/Lane/Signal Configurations table with columns for Northbound, Southbound, Westbound, Eastbound and rows for Existing, Ambient, Related, Project, Total, Lane, and Signal.

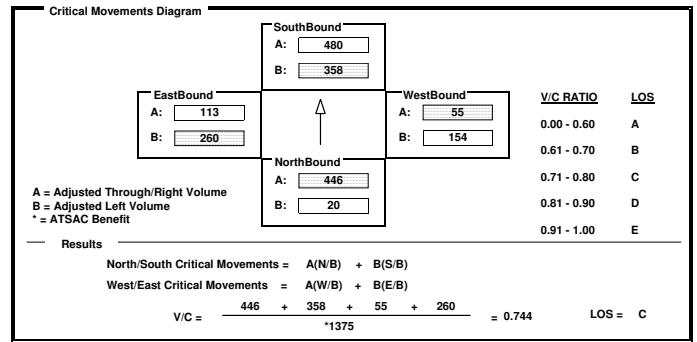

INTERSECTION DATA SUMMARY SHEET

N/S: La Cienega Blvd W/E: La Tijera Blvd I/S No: 88
AM/PM: AM Comments: Plus Project
COUNT DATE: STUDY DATE: GROWTH FACTOR:

Volume/Lane/Signal Configurations table with columns for Northbound, Southbound, Westbound, Eastbound and rows for Existing, Ambient, Related, Project, Total, Lane, and Signal.

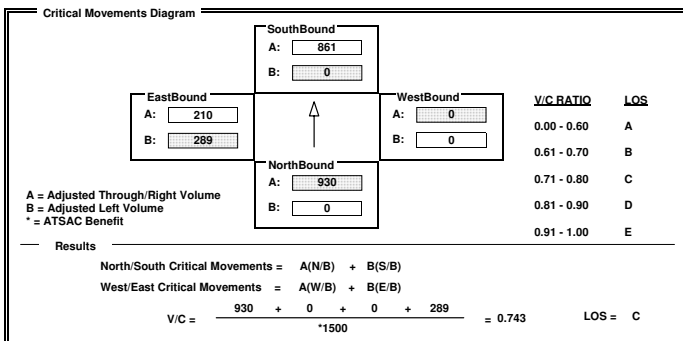

INTERSECTION DATA SUMMARY SHEET

N/S: Lincoln Blvd W/E: La Tijera Blvd I/S No: 99
AM/PM: AM Comments: Plus Project
COUNT DATE: STUDY DATE: GROWTH FACTOR:

Volume/Lane/Signal Configurations table with columns for Northbound, Southbound, Westbound, Eastbound and rows for Existing, Ambient, Related, Project, Total, Lane, and Signal.

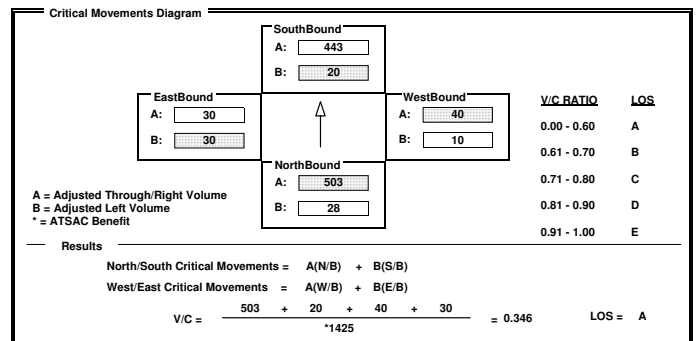

INTERSECTION DATA SUMMARY SHEET

N/S: W/E: I/S No:

AM/PM: Comments:

COUNT DATE: STUDY DATE: GROWTH FACTOR:

Volume/Lane/Signal Configurations

	NORTHBOUND			SOUTHBOUND			WESTBOUND			EASTBOUND		
	LT	TH	RT	LT	TH	RT	LT	TH	RT	LT	TH	RT
EXISTING	20	440	140	20	730	280	110	1200	30	160	540	20
AMBIENT												
RELATED												
PROJECT												
TOTAL	20	440	140	20	730	280	110	1200	30	160	540	20
LANE	1	2	1	1	2	1	1	2	1	1	2	1
SIGNAL	Prot-Fix	Auto	Prot-Fix	Auto	Prot-Fix	Auto	Prot-Fix	Auto	Prot-Fix	Free		

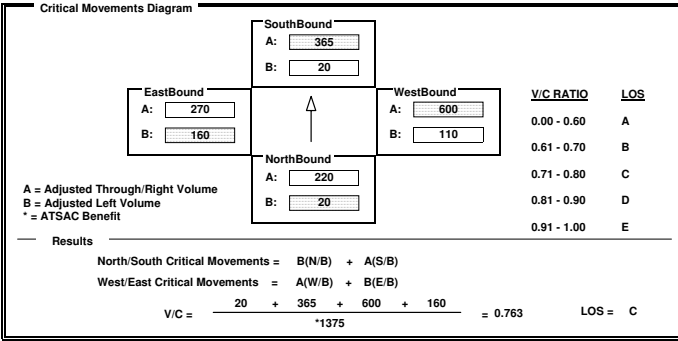

INTERSECTION DATA SUMMARY SHEET

N/S: W/E: I/S No:

AM/PM: Comments:

COUNT DATE: STUDY DATE: GROWTH FACTOR:

Volume/Lane/Signal Configurations

	NORTHBOUND			SOUTHBOUND			WESTBOUND			EASTBOUND		
	LT	TH	RT	LT	TH	RT	LT	TH	RT	LT	TH	RT
EXISTING	110	1590	170	70	1270	60	530	200	40	50	320	80
AMBIENT												
RELATED												
PROJECT												
TOTAL	110	1590	170	70	1270	60	530	200	40	50	320	80
LANE	1	3	1	1	3	1	1	2	1	1	2	1
SIGNAL	Prot-Fix	OLA	Prot-Fix	OLA	Perm	Auto	Prot-Fix	OLA				

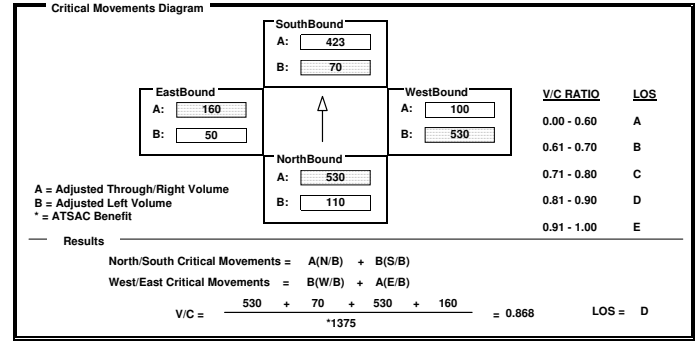

INTERSECTION DATA SUMMARY SHEET

N/S: W/E: I/S No:

AM/PM: Comments:

COUNT DATE: STUDY DATE: GROWTH FACTOR:

Volume/Lane/Signal Configurations

	NORTHBOUND			SOUTHBOUND			WESTBOUND			EASTBOUND		
	LT	TH	RT	LT	TH	RT	LT	TH	RT	LT	TH	RT
EXISTING	240	0	180	0	0	0	0	1220	420	510	820	0
AMBIENT												
RELATED												
PROJECT												
TOTAL	240	0	180	0	0	0	0	1220	420	510	820	0
LANE	1		1				5	1		2	3	
SIGNAL	Split	Auto	<none>	<none>	Perm	Auto	Prot-Fix	<none>				

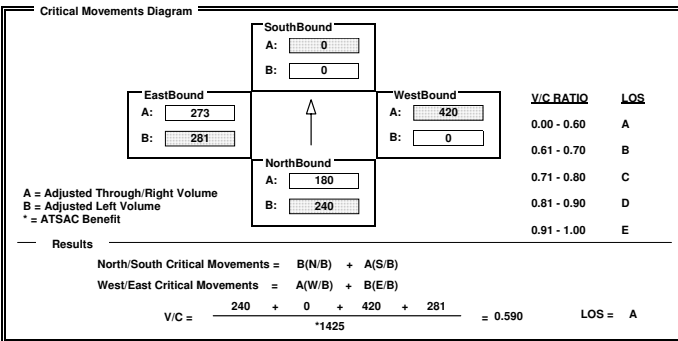

INTERSECTION DATA SUMMARY SHEET

N/S: W/E: I/S No:

AM/PM: Comments:

COUNT DATE: STUDY DATE: GROWTH FACTOR:

Volume/Lane/Signal Configurations

	NORTHBOUND			SOUTHBOUND			WESTBOUND			EASTBOUND		
	LT	TH	RT	LT	TH	RT	LT	TH	RT	LT	TH	RT
EXISTING	0	0	0	90	0	500	330	1130	0	0	1240	350
AMBIENT												
RELATED												
PROJECT												
TOTAL	0	0	0	90	0	500	330	1130	0	0	1240	350
LANE						1	1	2	3		4	1
SIGNAL	<none>	<none>	Split	<none>	Prot-Fix	<none>	Perm	Auto				

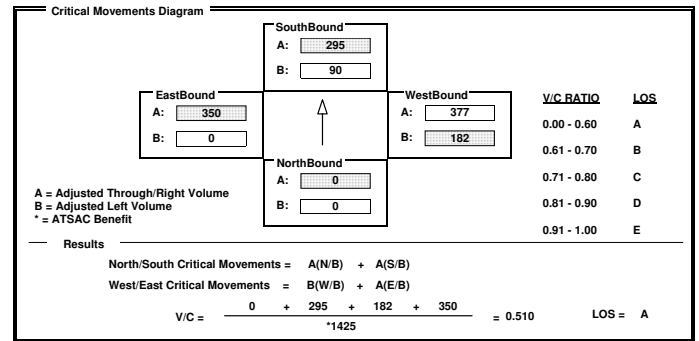

INTERSECTION DATA SUMMARY SHEET

N/S: Lincoln Blvd W/E: LMU Dr I/S No: 104
AM/PM: AM Comments: Plus Project
COUNT DATE: STUDY DATE: GROWTH FACTOR:

Volume/Lane/Signal Configurations table with columns for Northbound, Southbound, Westbound, Eastbound and rows for Existing, Ambient, Related, Project, Total, Lane, Phasing, RTOR, Signal.

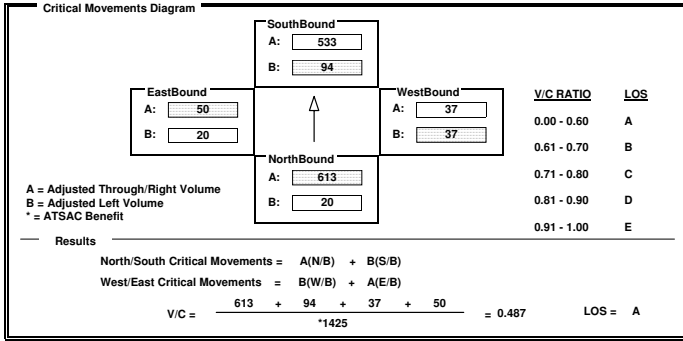

INTERSECTION DATA SUMMARY SHEET

N/S: Lincoln Blvd W/E: Manchester Blvd I/S No: 105
AM/PM: AM Comments: Plus Project
COUNT DATE: STUDY DATE: GROWTH FACTOR:

Volume/Lane/Signal Configurations table with columns for Northbound, Southbound, Westbound, Eastbound and rows for Existing, Ambient, Related, Project, Total, Lane, Phasing, RTOR, Signal.

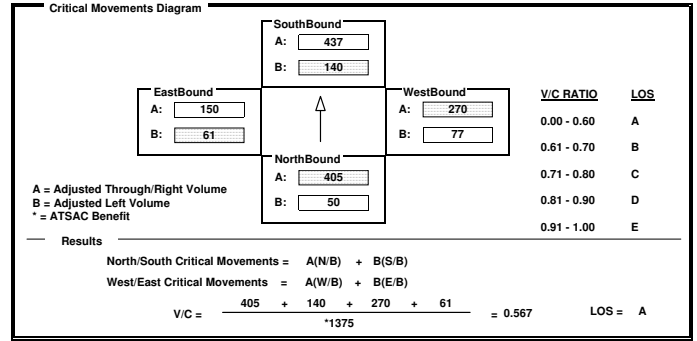

INTERSECTION DATA SUMMARY SHEET

N/S: Lincoln Blvd W/E: Marina Pointe Dr/ Maxella Ave I/S No: 106
AM/PM: AM Comments: Plus Project
COUNT DATE: STUDY DATE: GROWTH FACTOR:

Volume/Lane/Signal Configurations table with columns for Northbound, Southbound, Westbound, Eastbound and rows for Existing, Ambient, Related, Project, Total, Lane, Phasing, RTOR, Signal.

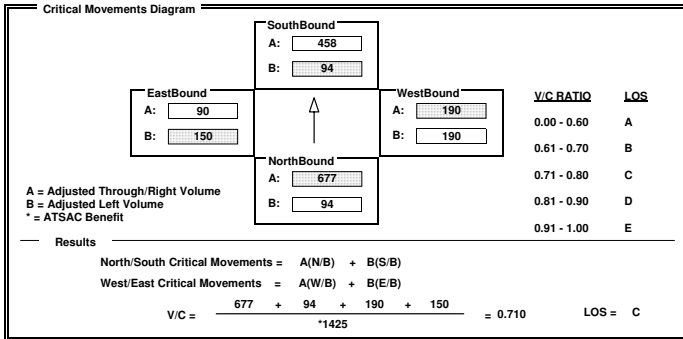

INTERSECTION DATA SUMMARY SHEET

N/S: Lincoln Blvd W/E: Mindanao Way I/S No: 107
AM/PM: AM Comments: Plus Project
COUNT DATE: STUDY DATE: GROWTH FACTOR:

Volume/Lane/Signal Configurations table with columns for Northbound, Southbound, Westbound, Eastbound and rows for Existing, Ambient, Related, Project, Total, Lane, Phasing, RTOR, Signal.

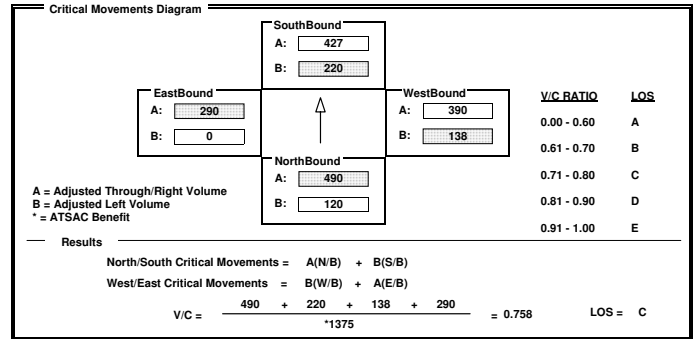

INTERSECTION DATA SUMMARY SHEET

N/S: W/E: I/S No:
 AM/PM: Comments:
 COUNT DATE: STUDY DATE: GROWTH FACTOR:

	NORTHBOUND			SOUTHBOUND			WESTBOUND			EASTBOUND		
	LT	TH	RT	LT	TH	RT	LT	TH	RT	LT	TH	RT
EXISTING	1440	2040	410	0	1710	10	0	0	10	0	0	1280
AMBIENT												
RELATED												
PROJECT												
TOTAL	1440	2040	410	0	1710	10	0	0	10	0	0	1280
LANE	4	2	1		3	1			1			4
SIGNAL	Prot-Fix	Auto		<none>	Auto		<none>	Auto		<none>	Auto	

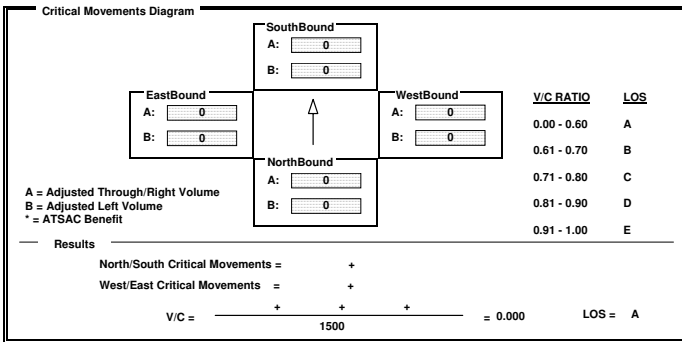

INTERSECTION DATA SUMMARY SHEET

N/S: W/E: I/S No:
 AM/PM: Comments:
 COUNT DATE: STUDY DATE: GROWTH FACTOR:

	NORTHBOUND			SOUTHBOUND			WESTBOUND			EASTBOUND		
	LT	TH	RT	LT	TH	RT	LT	TH	RT	LT	TH	RT
EXISTING	230	1710	170	200	1300	40	280	570	280	120	810	270
AMBIENT												
RELATED												
PROJECT												
TOTAL	230	1710	170	200	1300	40	280	570	280	120	810	270
LANE	2	2	1	2	2	1	2	2	1	2	3	1
SIGNAL	Prot-Fix	Auto		Prot-Fix	Auto		Prot-Fix	OLA		Prot-Fix	OLA	

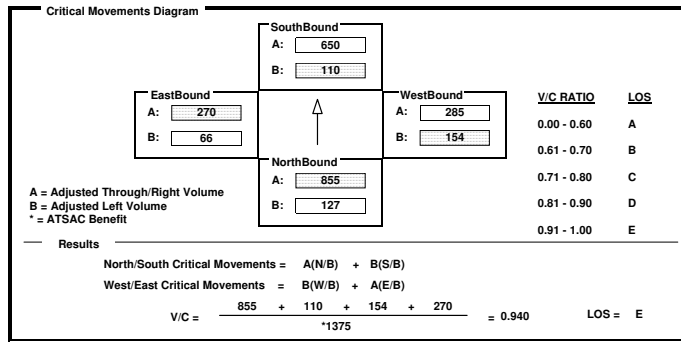

INTERSECTION DATA SUMMARY SHEET

N/S: W/E: I/S No:
 AM/PM: Comments:
 COUNT DATE: STUDY DATE: GROWTH FACTOR:

	NORTHBOUND			SOUTHBOUND			WESTBOUND			EASTBOUND		
	LT	TH	RT	LT	TH	RT	LT	TH	RT	LT	TH	RT
EXISTING	390	1790	270	230	1580	180	160	690	230	140	720	510
AMBIENT												
RELATED												
PROJECT												
TOTAL	390	1790	270	230	1580	180	160	690	230	140	720	510
LANE	2	2	1	2	2	1	2	2	1	2	2	1
SIGNAL	Prot-Fix	Auto		Prot-Fix	Auto		Prot-Fix	OLA		Prot-Fix	OLA	

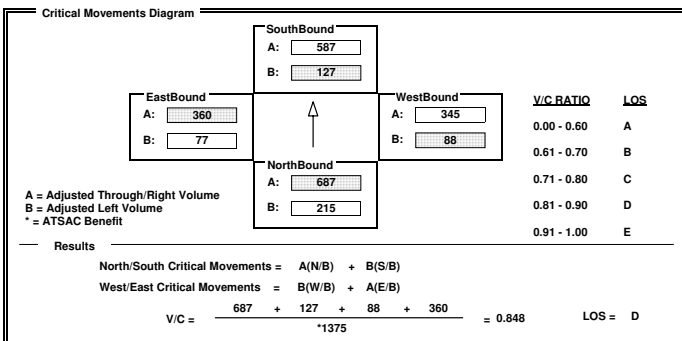

INTERSECTION DATA SUMMARY SHEET

N/S: W/E: I/S No:
 AM/PM: Comments:
 COUNT DATE: STUDY DATE: GROWTH FACTOR:

	NORTHBOUND			SOUTHBOUND			WESTBOUND			EASTBOUND		
	LT	TH	RT	LT	TH	RT	LT	TH	RT	LT	TH	RT
EXISTING	10	2110	10	110	1260	70	30	30	260	40	70	360
AMBIENT												
RELATED												
PROJECT												
TOTAL	10	2110	10	110	1260	70	30	30	260	40	70	360
LANE	1	3	1	1	2	1	1	1	1	2		1
SIGNAL	Perm	Auto		Prot-Fix	Auto		Perm	OLA		Prot-Fix	Auto	

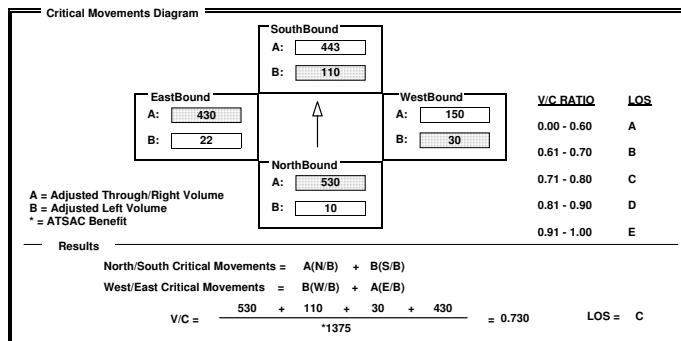

INTERSECTION DATA SUMMARY SHEET

N/S: Sepulveda Blvd W/E: Manchester Ave I/S No: 114
AM/PM: AM Comments: Plus Project
COUNT DATE: STUDY DATE: GROWTH FACTOR:

Volume/Lane/Signal Configurations table with columns for Northbound, Southbound, Westbound, Eastbound and rows for Existing, Ambient, Related, Project, Total, Lane, Phasing, RTOR, Signal.

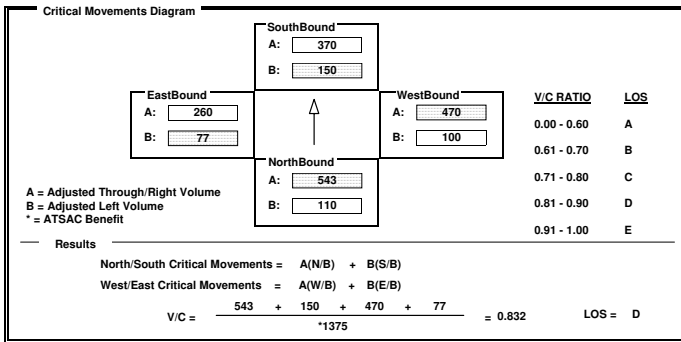

INTERSECTION DATA SUMMARY SHEET

N/S: Sepulveda Blvd W/E: Westchester Pkwy I/S No: 135
AM/PM: AM Comments: Plus Project
COUNT DATE: STUDY DATE: GROWTH FACTOR:

Volume/Lane/Signal Configurations table with columns for Northbound, Southbound, Westbound, Eastbound and rows for Existing, Ambient, Related, Project, Total, Lane, Phasing, RTOR, Signal.

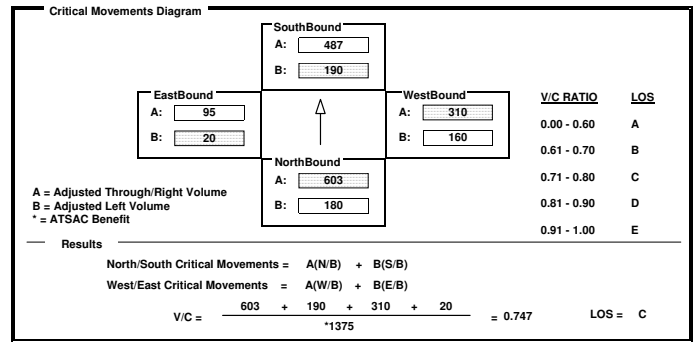

INTERSECTION DATA SUMMARY SHEET

N/S: Sepulveda Blvd W/E: 76th St/77th St I/S No: 136
AM/PM: AM Comments: Plus Project
COUNT DATE: STUDY DATE: GROWTH FACTOR:

Volume/Lane/Signal Configurations table with columns for Northbound, Southbound, Westbound, Eastbound and rows for Existing, Ambient, Related, Project, Total, Lane, Phasing, RTOR, Signal.

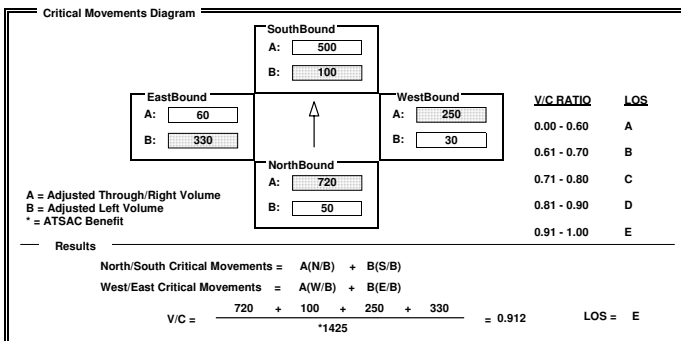

INTERSECTION DATA SUMMARY SHEET

N/S: Sepulveda Blvd W/E: 79 St/80th St I/S No: 137
AM/PM: AM Comments: Plus Project
COUNT DATE: STUDY DATE: GROWTH FACTOR:

Volume/Lane/Signal Configurations table with columns for Northbound, Southbound, Westbound, Eastbound and rows for Existing, Ambient, Related, Project, Total, Lane, Phasing, RTOR, Signal.

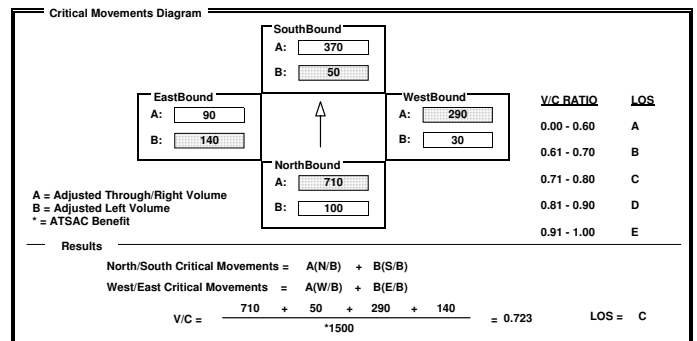

INTERSECTION DATA SUMMARY SHEET

N/S: W/E: I/S No:

AM/PM: Comments:

COUNT DATE: STUDY DATE: GROWTH FACTOR:

Volume/Lane/Signal Configurations

	NORTHBOUND			SOUTHBOUND			WESTBOUND			EASTBOUND		
	LT	TH	RT	LT	TH	RT	LT	TH	RT	LT	TH	RT
EXISTING	50	2040	10	30	1200	50	10	110	40	70	90	60
AMBIENT												
RELATED												
PROJECT												
TOTAL	50	2040	10	30	1200	50	10	110	40	70	90	60
LANE	1 2 1			1 2 1			1 1 1			1 1 1		
SIGNAL	Phasing: Perm		RTOR: Auto	Phasing: Perm		RTOR: Auto	Phasing: Perm		RTOR: Auto	Phasing: Perm		RTOR: Auto

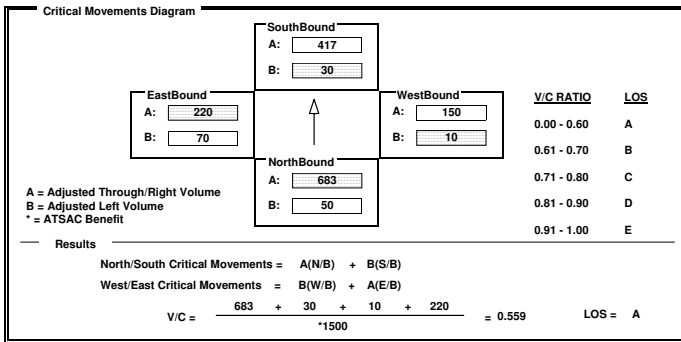

INTERSECTION DATA SUMMARY SHEET

N/S: W/E: I/S No:

AM/PM: Comments:

COUNT DATE: STUDY DATE: GROWTH FACTOR:

Volume/Lane/Signal Configurations

	NORTHBOUND			SOUTHBOUND			WESTBOUND			EASTBOUND		
	LT	TH	RT	LT	TH	RT	LT	TH	RT	LT	TH	RT
EXISTING	0	2370	0	0	0	0	0	0	2210	0	0	0
AMBIENT												
RELATED												
PROJECT												
TOTAL	0	2370	0	0	0	0	0	0	2210	0	0	0
LANE	3			0			3			0		
SIGNAL	Phasing: Split		RTOR: <none>	Phasing: <none>		RTOR: <none>	Phasing: Split		RTOR: <none>	Phasing: <none>		RTOR: <none>

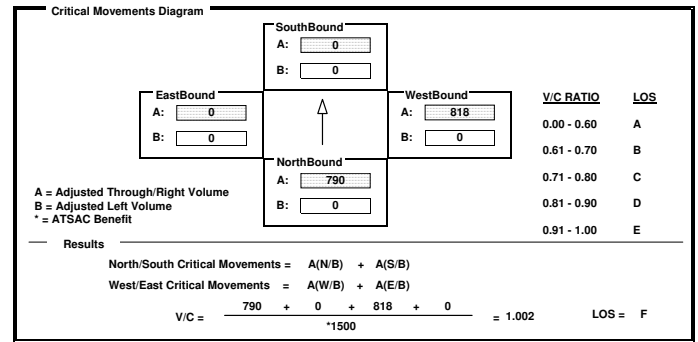

INTERSECTION DATA SUMMARY SHEET

N/S: W/E: I/S No:

AM/PM: Comments:

COUNT DATE: STUDY DATE: GROWTH FACTOR:

Volume/Lane/Signal Configurations

	NORTHBOUND			SOUTHBOUND			WESTBOUND			EASTBOUND		
	LT	TH	RT	LT	TH	RT	LT	TH	RT	LT	TH	RT
EXISTING	180	890	40	110	830	360	30	60	100	220	70	70
AMBIENT												
RELATED												
PROJECT												
TOTAL	180	890	40	110	830	360	30	60	100	220	70	70
LANE	1 2 1			1 3 1			1 1 1			2 1 1		
SIGNAL	Phasing: Prot-Fix		RTOR: Auto	Phasing: Perm		RTOR: Free	Phasing: Perm		RTOR: Auto	Phasing: Prot-Fix		RTOR: Auto

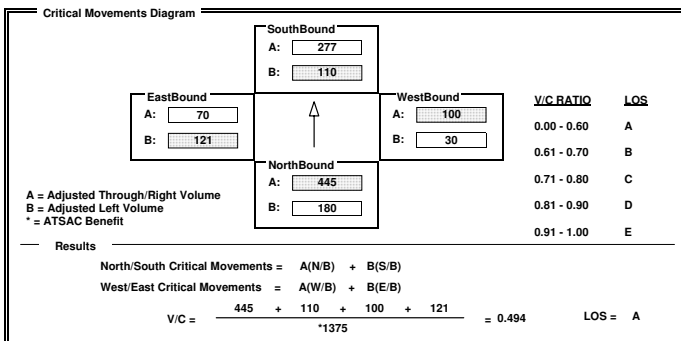

INTERSECTION DATA SUMMARY SHEET

N/S: W/E: I/S No:

AM/PM: Comments:

COUNT DATE: STUDY DATE: GROWTH FACTOR:

Volume/Lane/Signal Configurations

	NORTHBOUND			SOUTHBOUND			WESTBOUND			EASTBOUND		
	LT	TH	RT	LT	TH	RT	LT	TH	RT	LT	TH	RT
EXISTING	140	840	90	130	610	220	70	50	160	80	40	140
AMBIENT												
RELATED												
PROJECT												
TOTAL	140	840	90	130	610	220	70	50	160	80	40	140
LANE	1 2 1			1 2 1			1 1 1			1 1 1		
SIGNAL	Phasing: Perm		RTOR: Auto	Phasing: Perm		RTOR: Auto	Phasing: Perm		RTOR: Auto	Phasing: Perm		RTOR: Auto

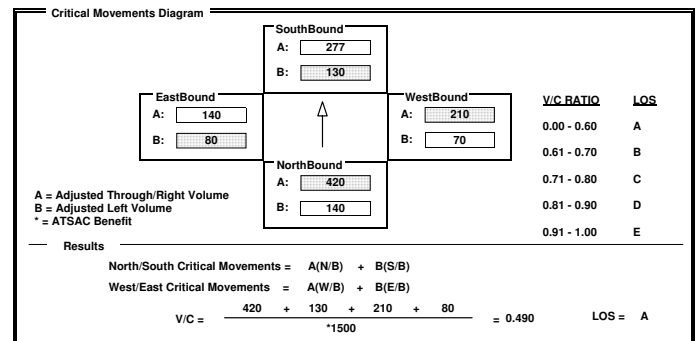

INTERSECTION DATA SUMMARY SHEET

N/S: W/E: I/S No:

AM/PM: Comments:

COUNT DATE: STUDY DATE: GROWTH FACTOR:

Volume/Lane/Signal Configurations

	NORTHBOUND			SOUTHBOUND			WESTBOUND			EASTBOUND		
	LT	TH	RT	LT	TH	RT	LT	TH	RT	LT	TH	RT
EXISTING	20	240	140	160	40	60	30	780	160	20	370	10
AMBIENT												
RELATED												
PROJECT												
TOTAL	20	240	140	160	40	60	30	780	160	20	370	10
LANE	1 1 1			1 1 1			1 1 1			1 1 1		
SIGNAL	Phasing		RTOR	Phasing		RTOR	Phasing		RTOR	Phasing		RTOR
	Perm		Auto	Perm		Auto	Perm		Auto	Perm		Auto

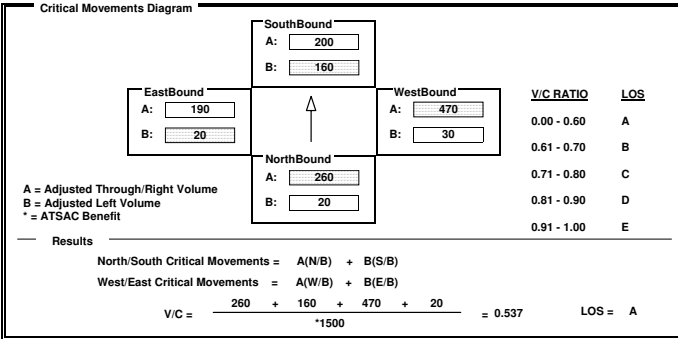

INTERSECTION DATA SUMMARY SHEET

N/S: W/E: I/S No:

AM/PM: Comments:

COUNT DATE: STUDY DATE: GROWTH FACTOR:

Volume/Lane/Signal Configurations

	NORTHBOUND			SOUTHBOUND			WESTBOUND			EASTBOUND		
	LT	TH	RT	LT	TH	RT	LT	TH	RT	LT	TH	RT
EXISTING	0	1000	120	160	460	0	990	0	90	0	0	0
AMBIENT												
RELATED												
PROJECT												
TOTAL	0	1000	120	160	460	0	990	0	90	0	0	0
LANE	1 1 1			1 2			1 1 1			1 1 1		
SIGNAL	Phasing		RTOR	Phasing		RTOR	Phasing		RTOR	Phasing		RTOR
	Perm		OLA	Prot-Fix		Auto	Split		Auto	Split		Auto

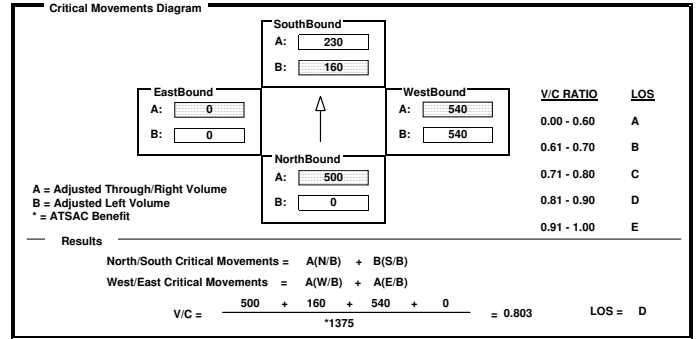

INTERSECTION DATA SUMMARY SHEET

N/S: W/E: I/S No:

AM/PM: Comments:

COUNT DATE: STUDY DATE: GROWTH FACTOR:

Volume/Lane/Signal Configurations

	NORTHBOUND			SOUTHBOUND			WESTBOUND			EASTBOUND		
	LT	TH	RT	LT	TH	RT	LT	TH	RT	LT	TH	RT
EXISTING	0	630	40	590	660	0	0	0	160	0	0	0
AMBIENT												
RELATED												
PROJECT												
TOTAL	0	630	40	590	660	0	0	0	160	0	0	0
LANE	1 1 1			2 2			2			2		
SIGNAL	Phasing		RTOR	Phasing		RTOR	Phasing		RTOR	Phasing		RTOR
	Perm		Auto	Prot-Fix		Auto	Split		OLA	Split		Auto

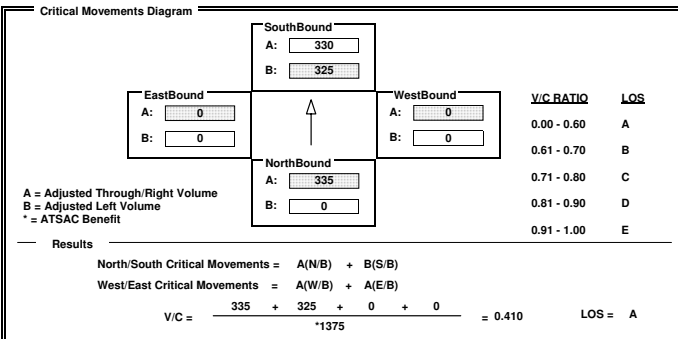

INTERSECTION DATA SUMMARY SHEET

N/S: W/E: I/S No:

AM/PM: Comments:

COUNT DATE: STUDY DATE: GROWTH FACTOR:

Volume/Lane/Signal Configurations

	NORTHBOUND			SOUTHBOUND			WESTBOUND			EASTBOUND		
	LT	TH	RT	LT	TH	RT	LT	TH	RT	LT	TH	RT
EXISTING	280	2480	50	110	2200	90	210	1240	310	10	430	130
AMBIENT												
RELATED												
PROJECT												
TOTAL	280	2480	50	110	2200	90	210	1240	310	10	430	130
LANE	2 2 1			1 2 1			1 2 1			2 1 1		
SIGNAL	Phasing		RTOR	Phasing		RTOR	Phasing		RTOR	Phasing		RTOR
	Prot-Fix		Auto	Prot-Fix		Auto	Prot-Fix		Auto	Perm		Auto

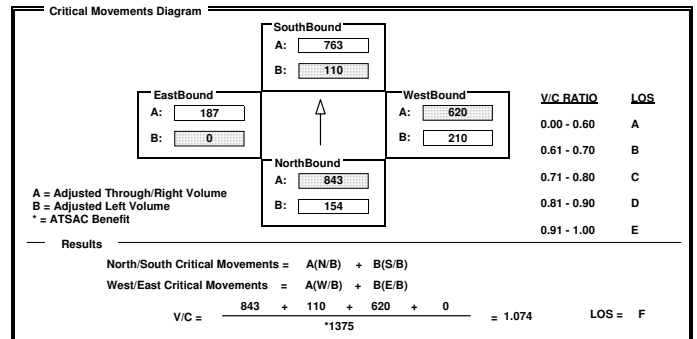

INTERSECTION DATA SUMMARY SHEET

N/S: W/E: I/S No:

AM/PM: Comments:

COUNT DATE: STUDY DATE: GROWTH FACTOR:

	NORTHBOUND			SOUTHBOUND			WESTBOUND			EASTBOUND		
	LT	TH	RT	LT	TH	RT	LT	TH	RT	LT	TH	RT
EXISTING	170	1500	120	80	690	70	220	1010	180	270	1440	90
AMBIENT												
RELATED												
PROJECT												
TOTAL	170	1500	120	80	690	70	220	1010	180	270	1440	90
LANE	1	2	1	1	2	1	1	2	1	1	2	1
SIGNAL	Phasing: <input type="text" value="Perm"/> RTOR: <input type="text" value="Auto"/>	Phasing: <input type="text" value="Prot-Fix"/> RTOR: <input type="text" value="Auto"/>	Phasing: <input type="text" value="Prot-Fix"/> RTOR: <input type="text" value="Auto"/>	Phasing: <input type="text" value="Prot-Fix"/> RTOR: <input type="text" value="Auto"/>	Phasing: <input type="text" value="Prot-Fix"/> RTOR: <input type="text" value="Auto"/>	Phasing: <input type="text" value="Prot-Fix"/> RTOR: <input type="text" value="Auto"/>	Phasing: <input type="text" value="Prot-Fix"/> RTOR: <input type="text" value="Auto"/>	Phasing: <input type="text" value="Prot-Fix"/> RTOR: <input type="text" value="Auto"/>	Phasing: <input type="text" value="Prot-Fix"/> RTOR: <input type="text" value="Auto"/>	Phasing: <input type="text" value="Prot-Fix"/> RTOR: <input type="text" value="Auto"/>	Phasing: <input type="text" value="Prot-Fix"/> RTOR: <input type="text" value="Auto"/>	Phasing: <input type="text" value="Prot-Fix"/> RTOR: <input type="text" value="Auto"/>

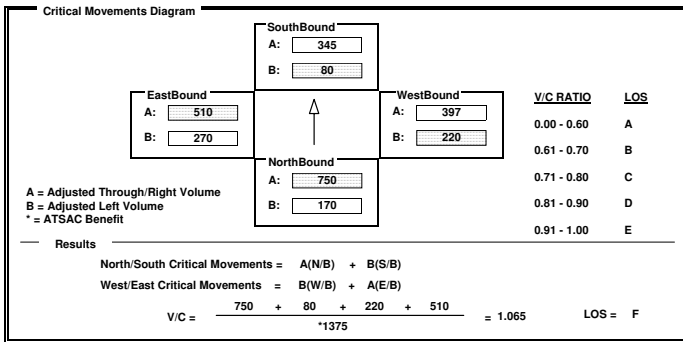

INTERSECTION DATA SUMMARY SHEET

N/S: W/E: I/S No:

AM/PM: Comments:

COUNT DATE: STUDY DATE: GROWTH FACTOR:

	NORTHBOUND			SOUTHBOUND			WESTBOUND			EASTBOUND		
	LT	TH	RT	LT	TH	RT	LT	TH	RT	LT	TH	RT
EXISTING	120	690	20	100	470	100	30	1000	160	160	470	70
AMBIENT												
RELATED												
PROJECT												
TOTAL	120	690	20	100	470	100	30	1000	160	160	470	70
LANE	1	1	1	1	2	1	1	2	1	1	2	1
SIGNAL	Phasing: <input type="text" value="Prot-Fix"/> RTOR: <input type="text" value="Auto"/>	Phasing: <input type="text" value="Prot-Fix"/> RTOR: <input type="text" value="Auto"/>	Phasing: <input type="text" value="Prot-Fix"/> RTOR: <input type="text" value="Auto"/>	Phasing: <input type="text" value="Prot-Fix"/> RTOR: <input type="text" value="Auto"/>	Phasing: <input type="text" value="Prot-Fix"/> RTOR: <input type="text" value="Auto"/>	Phasing: <input type="text" value="Prot-Fix"/> RTOR: <input type="text" value="Auto"/>	Phasing: <input type="text" value="Prot-Fix"/> RTOR: <input type="text" value="Auto"/>	Phasing: <input type="text" value="Prot-Fix"/> RTOR: <input type="text" value="Auto"/>	Phasing: <input type="text" value="Prot-Fix"/> RTOR: <input type="text" value="Auto"/>	Phasing: <input type="text" value="Prot-Fix"/> RTOR: <input type="text" value="Auto"/>	Phasing: <input type="text" value="Prot-Fix"/> RTOR: <input type="text" value="Auto"/>	Phasing: <input type="text" value="Prot-Fix"/> RTOR: <input type="text" value="Auto"/>

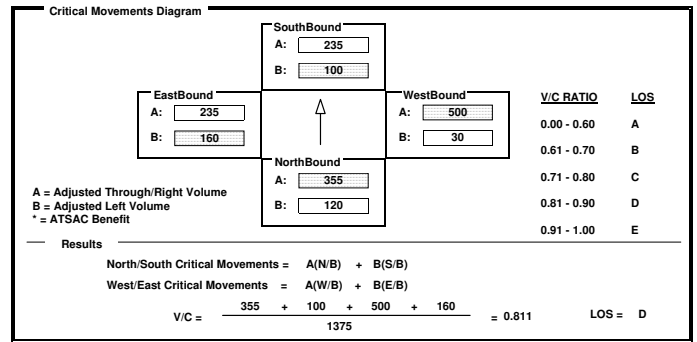

INTERSECTION DATA SUMMARY SHEET

N/S: W/E: I/S No:

AM/PM: Comments:

COUNT DATE: STUDY DATE: GROWTH FACTOR:

	NORTHBOUND			SOUTHBOUND			WESTBOUND			EASTBOUND		
	LT	TH	RT	LT	TH	RT	LT	TH	RT	LT	TH	RT
EXISTING	0	2310	810	150	0	0	1390	0	110	0	0	0
AMBIENT												
RELATED												
PROJECT												
TOTAL	0	2310	810	150	0	0	1390	0	110	0	0	0
LANE		2	1	1			2		1			
SIGNAL	Phasing: <input type="text" value="Prot-Fix"/> RTOR: <input type="text" value="Auto"/>	Phasing: <input type="text" value="Prot-Fix"/> RTOR: <input type="text" value="Auto"/>	Phasing: <input type="text" value="Prot-Fix"/> RTOR: <input type="text" value="Auto"/>	Phasing: <input type="text" value="Prot-Fix"/> RTOR: <input type="text" value="Auto"/>	Phasing: <input type="text" value="Split"/> RTOR: <input type="text" value="Free"/>	Phasing: <input type="text" value="Split"/> RTOR: <input type="text" value="Free"/>	Phasing: <input type="text" value="Split"/> RTOR: <input type="text" value="Free"/>	Phasing: <input type="text" value="Split"/> RTOR: <input type="text" value="Free"/>	Phasing: <input type="text" value="Split"/> RTOR: <input type="text" value="Free"/>	Phasing: <input type="text" value="Split"/> RTOR: <input type="text" value="Free"/>	Phasing: <input type="text" value="Split"/> RTOR: <input type="text" value="Free"/>	Phasing: <input type="text" value="Split"/> RTOR: <input type="text" value="Free"/>

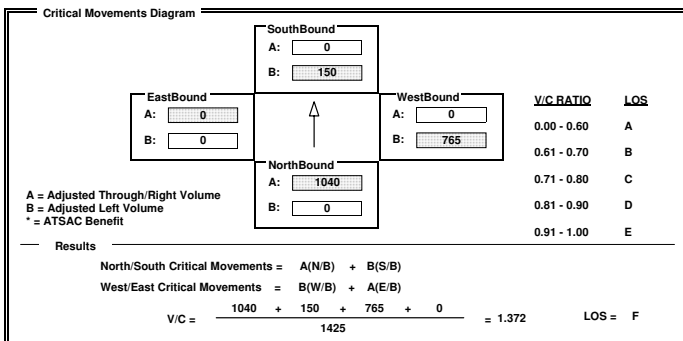

INTERSECTION DATA SUMMARY SHEET

N/S: W/E: I/S No:

AM/PM: Comments:

COUNT DATE: STUDY DATE: GROWTH FACTOR:

	NORTHBOUND			SOUTHBOUND			WESTBOUND			EASTBOUND		
	LT	TH	RT	LT	TH	RT	LT	TH	RT	LT	TH	RT
EXISTING	170	1000	170	100	520	100	270	1540	220	240	1290	100
AMBIENT												
RELATED												
PROJECT												
TOTAL	170	1000	170	100	520	100	270	1540	220	240	1290	100
LANE	1	2	1	1	2	1	2	2	1	2	2	1
SIGNAL	Phasing: <input type="text" value="Prot-Fix"/> RTOR: <input type="text" value="OLA"/>	Phasing: <input type="text" value="Prot-Fix"/> RTOR: <input type="text" value="OLA"/>	Phasing: <input type="text" value="Prot-Fix"/> RTOR: <input type="text" value="OLA"/>	Phasing: <input type="text" value="Prot-Fix"/> RTOR: <input type="text" value="OLA"/>	Phasing: <input type="text" value="Prot-Fix"/> RTOR: <input type="text" value="Auto"/>	Phasing: <input type="text" value="Prot-Fix"/> RTOR: <input type="text" value="Auto"/>	Phasing: <input type="text" value="Prot-Fix"/> RTOR: <input type="text" value="Auto"/>	Phasing: <input type="text" value="Prot-Fix"/> RTOR: <input type="text" value="Auto"/>	Phasing: <input type="text" value="Prot-Fix"/> RTOR: <input type="text" value="Auto"/>	Phasing: <input type="text" value="Prot-Fix"/> RTOR: <input type="text" value="Auto"/>	Phasing: <input type="text" value="Prot-Fix"/> RTOR: <input type="text" value="Auto"/>	Phasing: <input type="text" value="Prot-Fix"/> RTOR: <input type="text" value="Auto"/>

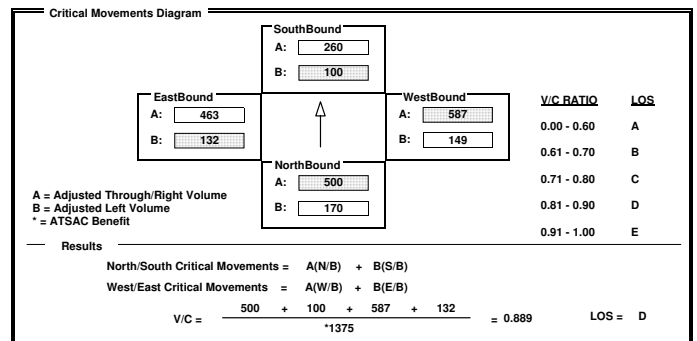

INTERSECTION DATA SUMMARY SHEET

N/S: Lincoln Blvd W/E: Rose Ave I/S No: 160
AM/PM: AM Comments: Cumulative (2013) With Project
COUNT DATE: STUDY DATE: GROWTH FACTOR:

Volume/Lane/Signal Configurations table with columns for Northbound, Southbound, Westbound, Eastbound and rows for Existing, Ambient, Related, Project, Total, Lane, Phasing, RTOR, Signal.

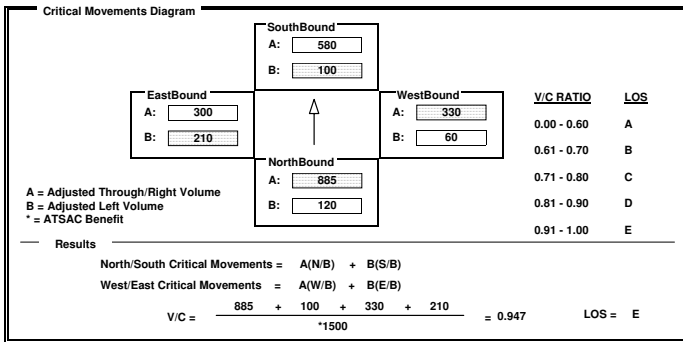

INTERSECTION DATA SUMMARY SHEET

N/S: Western Ave W/E: Century Blvd I/S No: 161
AM/PM: AM Comments: Cumulative (2013) With Project
COUNT DATE: STUDY DATE: GROWTH FACTOR:

Volume/Lane/Signal Configurations table with columns for Northbound, Southbound, Westbound, Eastbound and rows for Existing, Ambient, Related, Project, Total, Lane, Phasing, RTOR, Signal.

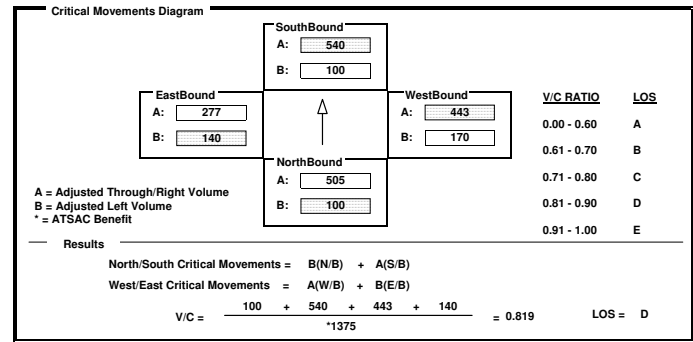

INTERSECTION DATA SUMMARY SHEET

N/S: La Cienega Blvd W/E: Jefferson Blvd I/S No: 200
AM/PM: AM Comments: Cumulative (2013) With Project
COUNT DATE: STUDY DATE: GROWTH FACTOR:

Volume/Lane/Signal Configurations table with columns for Northbound, Southbound, Westbound, Eastbound and rows for Existing, Ambient, Related, Project, Total, Lane, Phasing, RTOR, Signal.

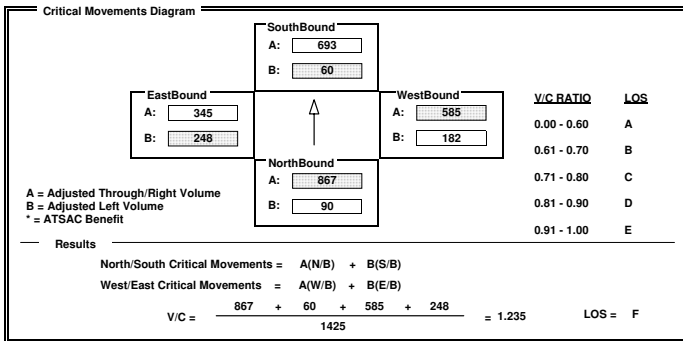

INTERSECTION DATA SUMMARY SHEET

N/S: Airport Blvd W/E: Westchester Blvd I/S No: 6
AM/PM: MD Comments: Plus Project
COUNT DATE: STUDY DATE: GROWTH FACTOR:

Volume/Lane/Signal Configurations table with columns for Northbound, Southbound, Westbound, Eastbound and rows for Existing, Ambient, Related, Project, Total, Lane, Phasing, RTOR, Signal.

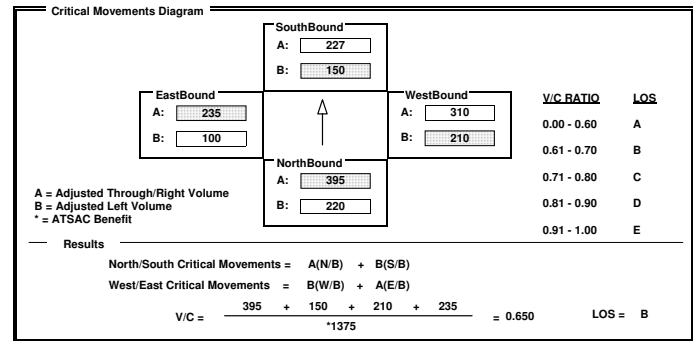

INTERSECTION DATA SUMMARY SHEET

N/S: W/E: I/S No:

AM/PM: Comments:

COUNT DATE: STUDY DATE: GROWTH FACTOR:

	NORTHBOUND			SOUTHBOUND			WESTBOUND			EASTBOUND		
	LT	TH	RT	LT	TH	RT	LT	TH	RT	LT	TH	RT
EXISTING	20	50	40	380	20	570	70	1860	440	760	1860	30
AMBIENT												
RELATED												
PROJECT												
TOTAL	20	50	40	380	20	570	70	1860	440	760	1860	30
LANE	1	2	1	2	1	1	1	4	1	2	4	1
SIGNAL	Phasing: Split	RTOR: Auto		Phasing: Split	RTOR: Auto		Phasing: Prot-Fix	RTOR: OLA		Phasing: Prot-Fix	RTOR: Auto	

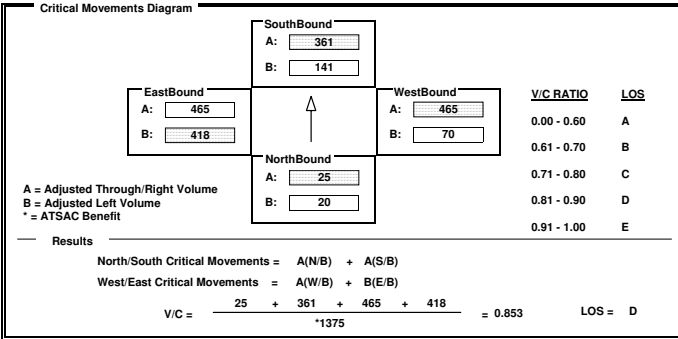

INTERSECTION DATA SUMMARY SHEET

N/S: W/E: I/S No:

AM/PM: Comments:

COUNT DATE: STUDY DATE: GROWTH FACTOR:

	NORTHBOUND			SOUTHBOUND			WESTBOUND			EASTBOUND		
	LT	TH	RT	LT	TH	RT	LT	TH	RT	LT	TH	RT
EXISTING	50	60	700	80	130	20	610	960	30	30	590	20
AMBIENT												
RELATED												
PROJECT												
TOTAL	50	60	700	80	130	20	610	960	30	30	590	20
LANE	1	2	1	1	1	1	2	1	1	1	2	1
SIGNAL	Phasing: Split	RTOR: OLA		Phasing: Split	RTOR: Auto		Phasing: Prot-Fix	RTOR: Auto		Phasing: Prot-Fix	RTOR: Auto	

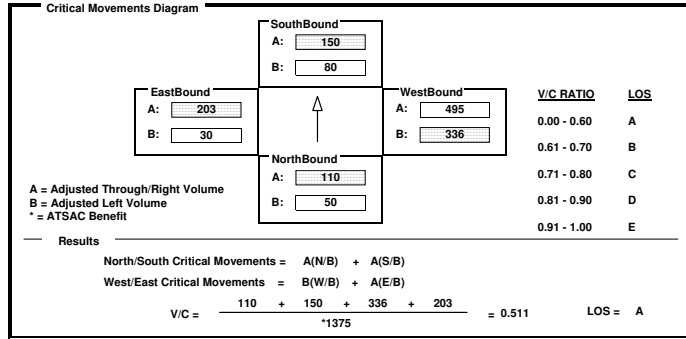

INTERSECTION DATA SUMMARY SHEET

N/S: W/E: I/S No:

AM/PM: Comments:

COUNT DATE: STUDY DATE: GROWTH FACTOR:

	NORTHBOUND			SOUTHBOUND			WESTBOUND			EASTBOUND		
	LT	TH	RT	LT	TH	RT	LT	TH	RT	LT	TH	RT
EXISTING	120	770	340	70	650	30	130	890	60	30	1070	90
AMBIENT												
RELATED												
PROJECT												
TOTAL	120	770	340	70	650	30	130	890	60	30	1070	90
LANE	1	2	1	1	1	1	1	2	1	1	2	1
SIGNAL	Phasing: Prot-Fix	RTOR: Auto		Phasing: Prot-Fix	RTOR: Auto		Phasing: Prot-Fix	RTOR: Auto		Phasing: Prot-Fix	RTOR: Auto	

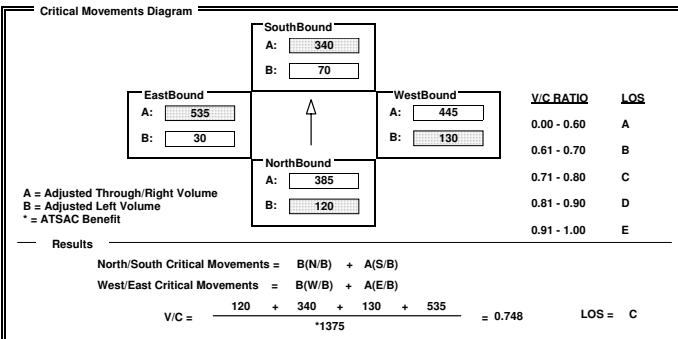

INTERSECTION DATA SUMMARY SHEET

N/S: W/E: I/S No:

AM/PM: Comments:

COUNT DATE: STUDY DATE: GROWTH FACTOR:

	NORTHBOUND			SOUTHBOUND			WESTBOUND			EASTBOUND		
	LT	TH	RT	LT	TH	RT	LT	TH	RT	LT	TH	RT
EXISTING	250	500	120	160	330	150	90	560	80	100	500	170
AMBIENT												
RELATED												
PROJECT												
TOTAL	250	500	120	160	330	150	90	560	80	100	500	170
LANE	1	2	1	1	1	1	1	1	1	1	1	1
SIGNAL	Phasing: Perm	RTOR: Auto		Phasing: Perm	RTOR: Auto		Phasing: Perm	RTOR: Auto		Phasing: Perm	RTOR: Auto	

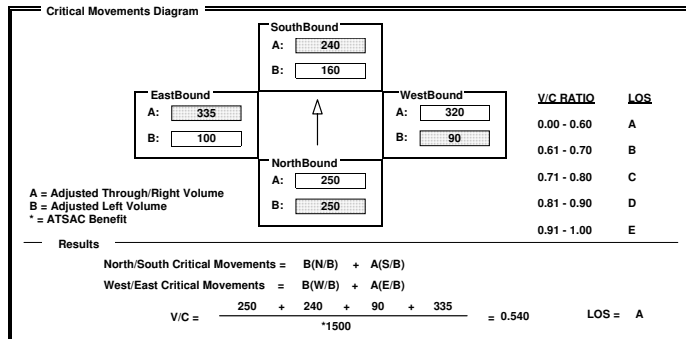

INTERSECTION DATA SUMMARY SHEET

N/S: Aviation Blvd W/E: Century Blvd I/S No: 14
AM/PM: MD Comments: Plus Project
COUNT DATE: STUDY DATE: GROWTH FACTOR:

Volume/Lane/Signal Configurations table with columns for Northbound, Southbound, Westbound, Eastbound and rows for Existing, Ambient, Related, Project, Total, Lane, Phasing, RTOR, Signal.

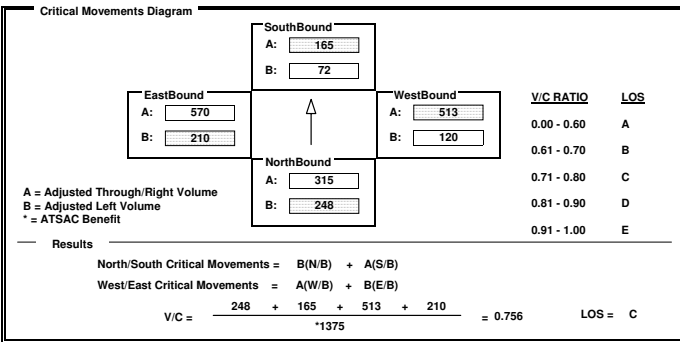

INTERSECTION DATA SUMMARY SHEET

N/S: Aviation Blvd W/E: Imperial Hwy I/S No: 16
AM/PM: MD Comments: Plus Project
COUNT DATE: STUDY DATE: GROWTH FACTOR:

Volume/Lane/Signal Configurations table with columns for Northbound, Southbound, Westbound, Eastbound and rows for Existing, Ambient, Related, Project, Total, Lane, Phasing, RTOR, Signal.

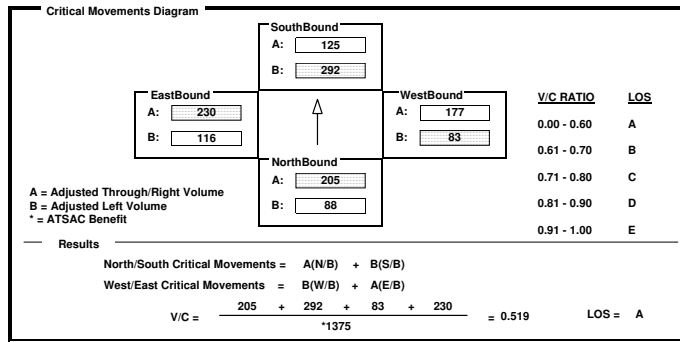

INTERSECTION DATA SUMMARY SHEET

N/S: Lincoln Blvd W/E: Bali Way I/S No: 21
AM/PM: MD Comments: Plus Project
COUNT DATE: STUDY DATE: GROWTH FACTOR:

Volume/Lane/Signal Configurations table with columns for Northbound, Southbound, Westbound, Eastbound and rows for Existing, Ambient, Related, Project, Total, Lane, Phasing, RTOR, Signal.

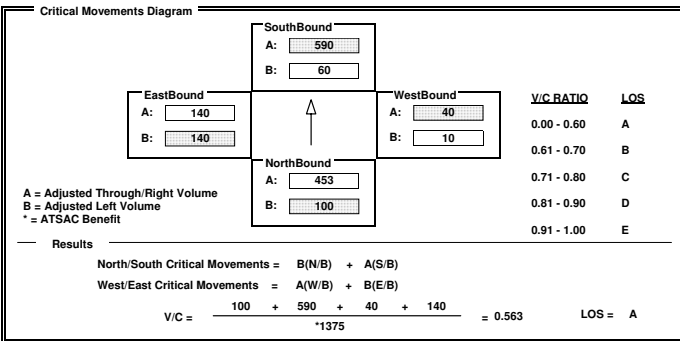

INTERSECTION DATA SUMMARY SHEET

N/S: Lincoln Blvd W/E: Bluff Creek Dr I/S No: 22
AM/PM: MD Comments: Plus Project
COUNT DATE: STUDY DATE: GROWTH FACTOR:

Volume/Lane/Signal Configurations table with columns for Northbound, Southbound, Westbound, Eastbound and rows for Existing, Ambient, Related, Project, Total, Lane, Phasing, RTOR, Signal.

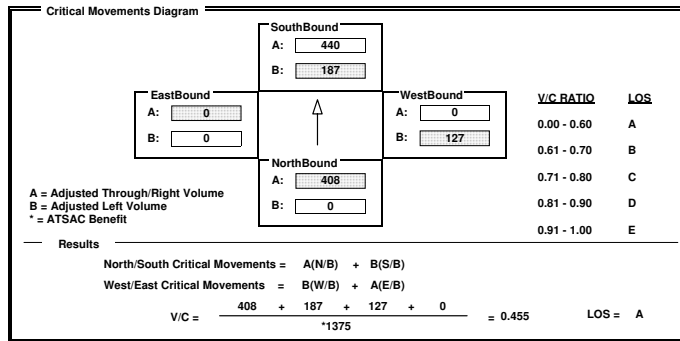

INTERSECTION DATA SUMMARY SHEET

N/S: W/E: I/S No:

AM/PM: Comments:

COUNT DATE: STUDY DATE: GROWTH FACTOR:

	NORTHBOUND			SOUTHBOUND			WESTBOUND			EASTBOUND		
	LT	TH	RT	LT	TH	RT	LT	TH	RT	LT	TH	RT
EXISTING	190	800	190	90	820	140	450	680	20	210	590	100
AMBIENT												
RELATED												
PROJECT												
TOTAL	190	800	190	90	820	140	450	680	20	210	590	100
LANE												
SIGNAL	Prot-Fix		Auto	Prot-Fix		Auto	Prot-Fix		Auto	Prot-Fix		Auto

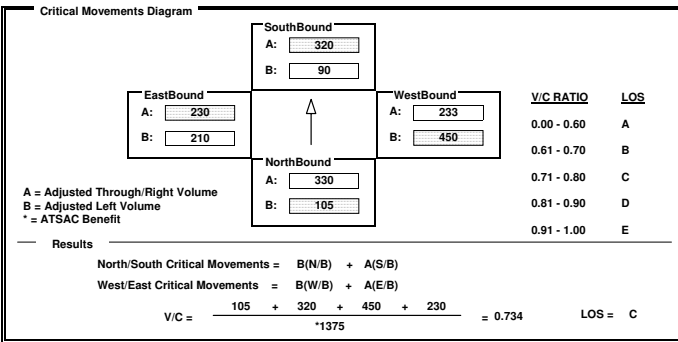

INTERSECTION DATA SUMMARY SHEET

N/S: W/E: I/S No:

AM/PM: Comments:

COUNT DATE: STUDY DATE: GROWTH FACTOR:

	NORTHBOUND			SOUTHBOUND			WESTBOUND			EASTBOUND		
	LT	TH	RT	LT	TH	RT	LT	TH	RT	LT	TH	RT
EXISTING	180	290	410	400	480	880	170	1130	390	130	1250	680
AMBIENT												
RELATED												
PROJECT												
TOTAL	180	290	410	400	480	880	170	1130	390	130	1250	680
LANE												
SIGNAL	Prot-Fix		OLA	Prot-Fix		OLA	Prot-Fix		Auto	Prot-Fix		OLA

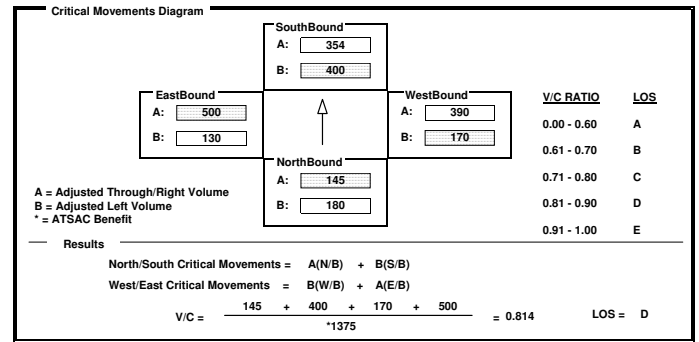

INTERSECTION DATA SUMMARY SHEET

N/S: W/E: I/S No:

AM/PM: Comments:

COUNT DATE: STUDY DATE: GROWTH FACTOR:

	NORTHBOUND			SOUTHBOUND			WESTBOUND			EASTBOUND		
	LT	TH	RT	LT	TH	RT	LT	TH	RT	LT	TH	RT
EXISTING	0	2970	50	0	1570	270	530	100	300	0	0	0
AMBIENT												
RELATED												
PROJECT												
TOTAL	0	2970	50	0	1570	270	530	100	300	0	0	0
LANE												
SIGNAL	Perm		Free	Perm		Auto	Split		Auto	<none>		Auto

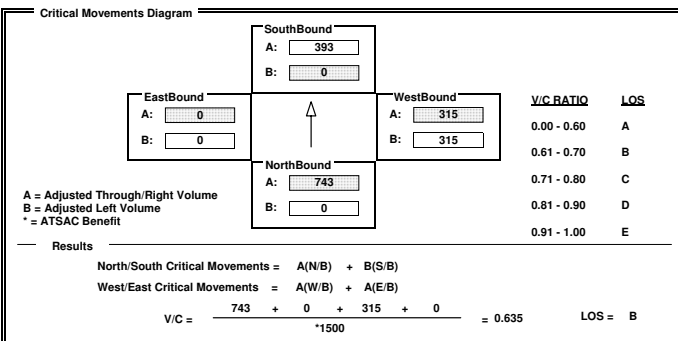

INTERSECTION DATA SUMMARY SHEET

N/S: W/E: I/S No:

AM/PM: Comments:

COUNT DATE: STUDY DATE: GROWTH FACTOR:

	NORTHBOUND			SOUTHBOUND			WESTBOUND			EASTBOUND		
	LT	TH	RT	LT	TH	RT	LT	TH	RT	LT	TH	RT
EXISTING	90	20	170	80	20	50	90	660	40	60	850	50
AMBIENT												
RELATED												
PROJECT												
TOTAL	90	20	170	80	20	50	90	660	40	60	850	50
LANE												
SIGNAL	Split		OLA	Split		Auto	Prot-Fix		Auto	Prot-Fix		Auto

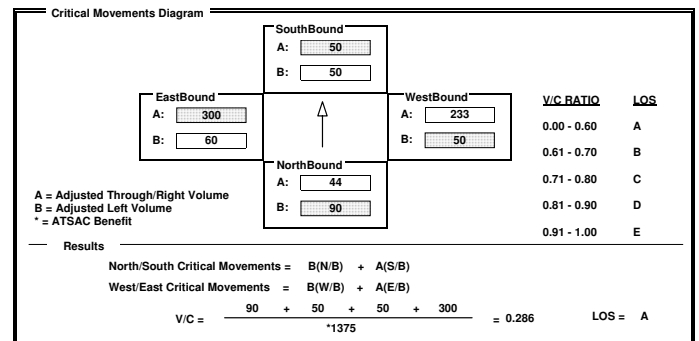

INTERSECTION DATA SUMMARY SHEET

N/S: Lincoln Blvd W/E: Fiji Way I/S No: 56
AM/PM: MD Comments: Plus Project
COUNT DATE: STUDY DATE: GROWTH FACTOR:

Volume/Lane/Signal Configurations table with columns for Northbound, Southbound, Westbound, Eastbound and rows for Existing, Ambient, Related, Project, Total, Lane, and Signal.

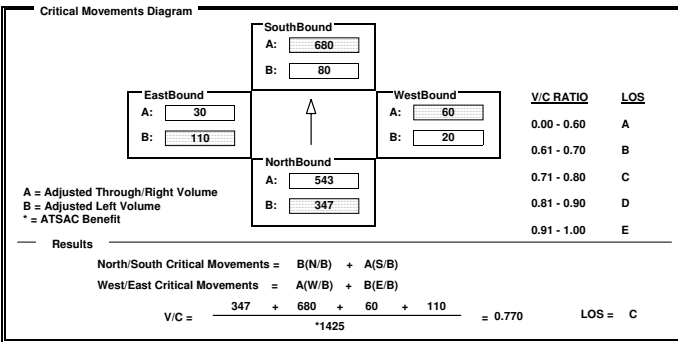

INTERSECTION DATA SUMMARY SHEET

N/S: Sepulveda Blvd W/E: Howard Hughes Pkwy I/S No: 65
AM/PM: MD Comments: Plus Project
COUNT DATE: STUDY DATE: GROWTH FACTOR:

Volume/Lane/Signal Configurations table with columns for Northbound, Southbound, Westbound, Eastbound and rows for Existing, Ambient, Related, Project, Total, Lane, and Signal.

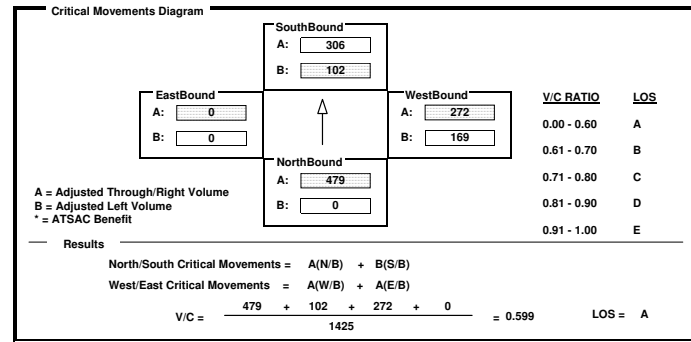

INTERSECTION DATA SUMMARY SHEET

N/S: La Cienega Blvd W/E: Imperial Hwy I/S No: 67
AM/PM: MD Comments: Plus Project
COUNT DATE: STUDY DATE: GROWTH FACTOR:

Volume/Lane/Signal Configurations table with columns for Northbound, Southbound, Westbound, Eastbound and rows for Existing, Ambient, Related, Project, Total, Lane, and Signal.

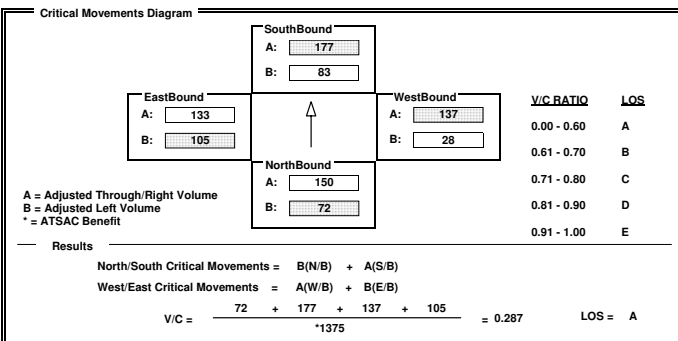

INTERSECTION DATA SUMMARY SHEET

N/S: Sepulveda Blvd W/E: Imperial Hwy I/S No: 71
AM/PM: MD Comments: Plus Project
COUNT DATE: STUDY DATE: GROWTH FACTOR:

Volume/Lane/Signal Configurations table with columns for Northbound, Southbound, Westbound, Eastbound and rows for Existing, Ambient, Related, Project, Total, Lane, and Signal.

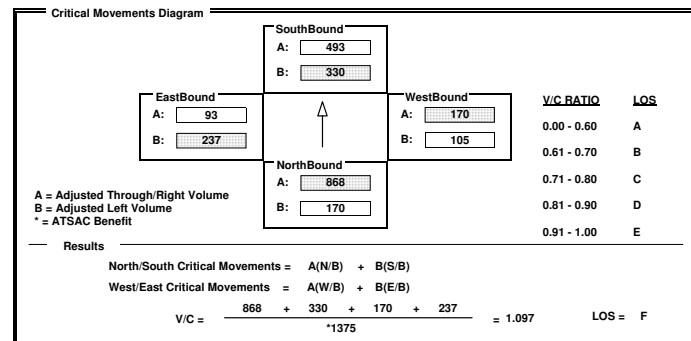

INTERSECTION DATA SUMMARY SHEET

N/S: 105 WB Off Ramps/Nash St W/E: Imperial Hwy I/S No: 73
 AM/PM: MD Comments: Plus Project
 COUNT DATE: STUDY DATE: GROWTH FACTOR:

	NORTHBOUND			SOUTHBOUND			WESTBOUND			EASTBOUND		
	LT	TH	RT	LT	TH	RT	LT	TH	RT	LT	TH	RT
EXISTING	40	0	70	70	380	220	90	810	0	0	720	60
AMBIENT												
RELATED												
PROJECT												
TOTAL	40	0	70	70	380	220	90	810	0	0	720	60
LANE	1	2	1	1	1	1	2	3	1	2	1	1
PHASING	Split	Auto	Split	Auto	Prot-Fix	Auto	Prot-Fix	Auto	Perm	Auto	Prot-Fix	Auto

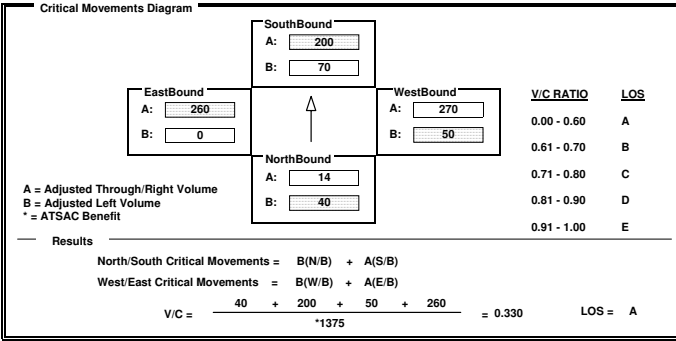

INTERSECTION DATA SUMMARY SHEET

N/S: 105 EB On Ramps W/E: Imperial Hwy I/S No: 74
 AM/PM: MD Comments: Plus Project
 COUNT DATE: STUDY DATE: GROWTH FACTOR:

	NORTHBOUND			SOUTHBOUND			WESTBOUND			EASTBOUND		
	LT	TH	RT	LT	TH	RT	LT	TH	RT	LT	TH	RT
EXISTING	550	0	560	0	0	0	270	590	0	0	280	730
AMBIENT												
RELATED												
PROJECT												
TOTAL	550	0	560	0	0	0	270	590	0	0	280	730
LANE	2	2	2	2	2	2	2	2	2	2	1	1
PHASING	Split	OLA	<none>	<none>	Prot-Fix	Auto	Prot-Fix	Auto	Perm	OLA	Prot-Fix	OLA

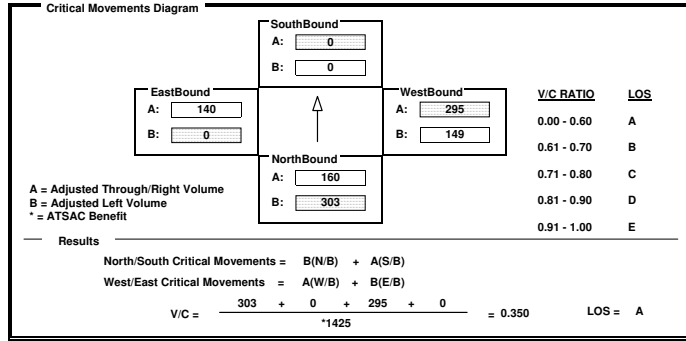

INTERSECTION DATA SUMMARY SHEET

N/S: Lincoln Blvd W/E: Jefferson Blvd I/S No: 78
 AM/PM: MD Comments: Plus Project
 COUNT DATE: STUDY DATE: GROWTH FACTOR:

	NORTHBOUND			SOUTHBOUND			WESTBOUND			EASTBOUND		
	LT	TH	RT	LT	TH	RT	LT	TH	RT	LT	TH	RT
EXISTING	20	1420	260	920	1610	290	430	100	780	100	150	60
AMBIENT												
RELATED												
PROJECT												
TOTAL	20	1420	260	920	1610	290	430	100	780	100	150	60
LANE	1	4	1	2	3	1	2	2	2	1	2	1
PHASING	Prot-Fix	OLA	Prot-Fix	OLA	Prot-Fix	OLA	Prot-Fix	OLA	Prot-Fix	Auto	Prot-Fix	Auto

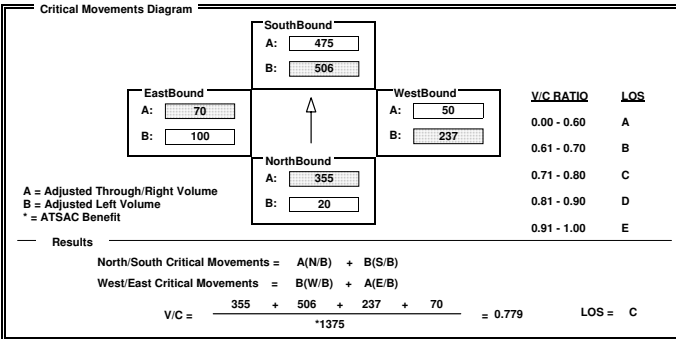

INTERSECTION DATA SUMMARY SHEET

N/S: La Cienega Blvd W/E: La Tijera Blvd I/S No: 88
 AM/PM: MD Comments: Plus Project
 COUNT DATE: STUDY DATE: GROWTH FACTOR:

	NORTHBOUND			SOUTHBOUND			WESTBOUND			EASTBOUND		
	LT	TH	RT	LT	TH	RT	LT	TH	RT	LT	TH	RT
EXISTING	0	1750	120	0	1670	960	0	0	0	780	220	20
AMBIENT												
RELATED												
PROJECT												
TOTAL	0	1750	120	0	1670	960	0	0	0	780	220	20
LANE	2	1	1	3	1	1	3	1	1	3	1	1
PHASING	Perm	Auto	Perm	OLA	<none>	<none>	Split	Auto	Perm	Auto	Perm	Auto

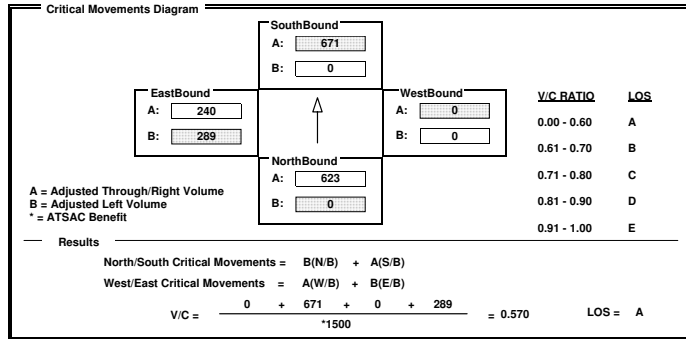

INTERSECTION DATA SUMMARY SHEET

N/S: Lincoln Blvd W/E: La Tijera Blvd I/S No: 99
AM/PM: MD Comments: Plus Project
COUNT DATE: STUDY DATE: GROWTH FACTOR:

Volume/Lane/Signal Configurations table with columns for Northbound, Southbound, Westbound, Eastbound and rows for Existing, Ambient, Related, Project, Total, Lane, and Signal.

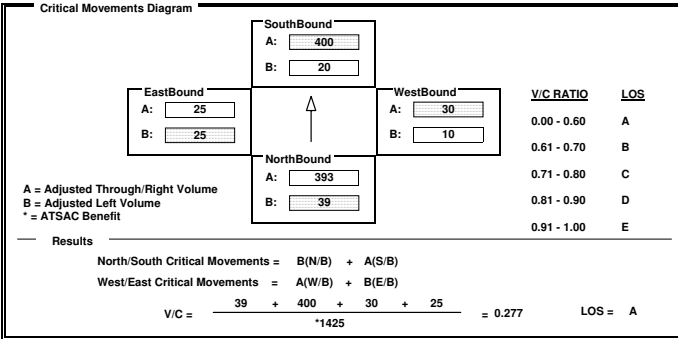

INTERSECTION DATA SUMMARY SHEET

N/S: La Tijera W/E: Manchester Ave I/S No: 100
AM/PM: MD Comments: Plus Project
COUNT DATE: STUDY DATE: GROWTH FACTOR:

Volume/Lane/Signal Configurations table with columns for Northbound, Southbound, Westbound, Eastbound and rows for Existing, Ambient, Related, Project, Total, Lane, and Signal.

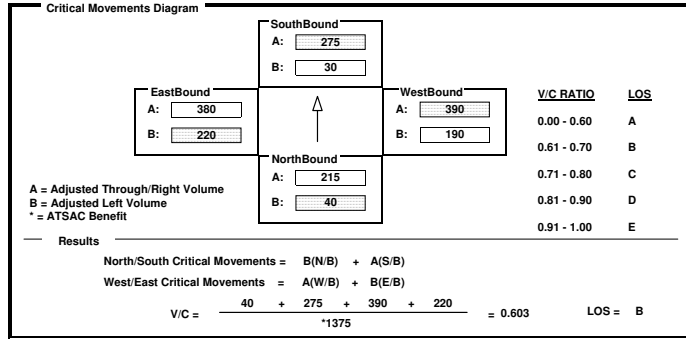

INTERSECTION DATA SUMMARY SHEET

N/S: Sepulveda Blvd W/E: La Tijera Blvd I/S No: 101
AM/PM: MD Comments: Plus Project
COUNT DATE: STUDY DATE: GROWTH FACTOR:

Volume/Lane/Signal Configurations table with columns for Northbound, Southbound, Westbound, Eastbound and rows for Existing, Ambient, Related, Project, Total, Lane, and Signal.

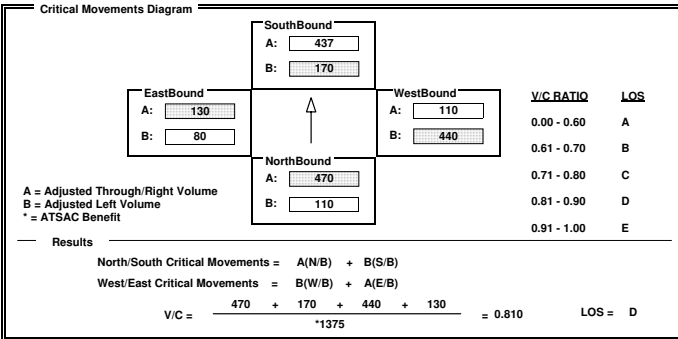

INTERSECTION DATA SUMMARY SHEET

N/S: 405 NB Ramps W/E: La Tijera Blvd I/S No: 102
AM/PM: MD Comments: Plus Project
COUNT DATE: STUDY DATE: GROWTH FACTOR:

Volume/Lane/Signal Configurations table with columns for Northbound, Southbound, Westbound, Eastbound and rows for Existing, Ambient, Related, Project, Total, Lane, and Signal.

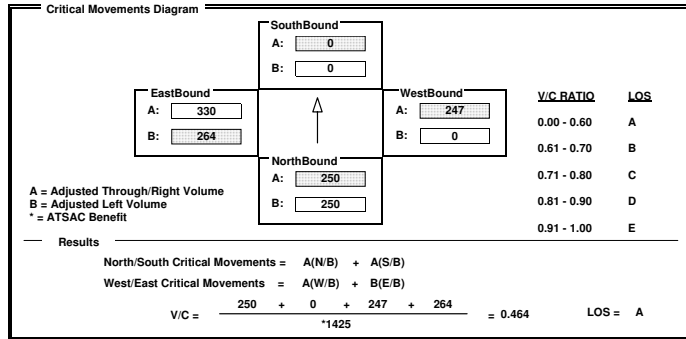

INTERSECTION DATA SUMMARY SHEET

N/S: W/E: I/S No:

AM/PM: Comments:

COUNT DATE: STUDY DATE: GROWTH FACTOR:

	NORTHBOUND			SOUTHBOUND			WESTBOUND			EASTBOUND		
	LT	TH	RT	LT	TH	RT	LT	TH	RT	LT	TH	RT
EXISTING	0	0	0	180	0	540	250	1240	0	0	1290	230
AMBIENT												
RELATED												
PROJECT												
TOTAL	0	0	0	180	0	540	250	1240	0	0	1290	230
LANE												
SIGNAL	Phasing <none> RTOR <none>			Phasing Split RTOR <none>			Phasing Prot-Fix RTOR <none>			Phasing Perm RTOR Auto		

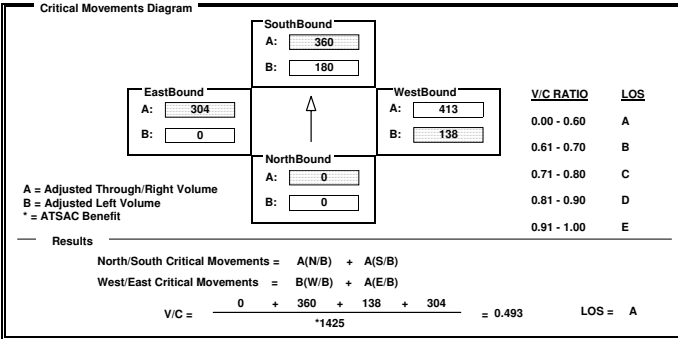

INTERSECTION DATA SUMMARY SHEET

N/S: W/E: I/S No:

AM/PM: Comments:

COUNT DATE: STUDY DATE: GROWTH FACTOR:

	NORTHBOUND			SOUTHBOUND			WESTBOUND			EASTBOUND		
	LT	TH	RT	LT	TH	RT	LT	TH	RT	LT	TH	RT
EXISTING	10	1600	120	140	1820	30	100	10	100	30	10	20
AMBIENT												
RELATED												
PROJECT												
TOTAL	10	1600	120	140	1820	30	100	10	100	30	10	20
LANE												
SIGNAL	Phasing Prot-Fix RTOR OLA			Phasing Prot-Fix RTOR Auto			Phasing Perm RTOR OLA			Phasing Perm RTOR Auto		

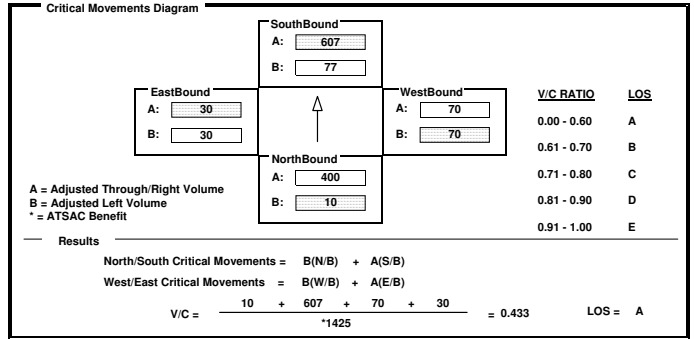

INTERSECTION DATA SUMMARY SHEET

N/S: W/E: I/S No:

AM/PM: Comments:

COUNT DATE: STUDY DATE: GROWTH FACTOR:

	NORTHBOUND			SOUTHBOUND			WESTBOUND			EASTBOUND		
	LT	TH	RT	LT	TH	RT	LT	TH	RT	LT	TH	RT
EXISTING	70	1050	140	200	1020	130	210	340	260	130	250	80
AMBIENT												
RELATED												
PROJECT												
TOTAL	70	1050	140	200	1020	130	210	340	260	130	250	80
LANE												
SIGNAL	Phasing Prot-Fix RTOR Auto			Phasing Prot-Fix RTOR Auto			Phasing Prot-Fix RTOR OLA			Phasing Prot-Fix RTOR OLA		

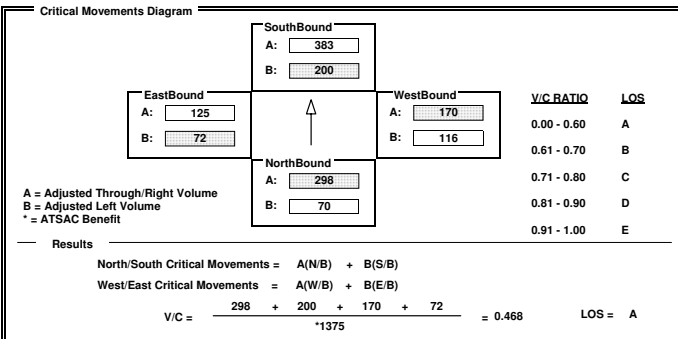

INTERSECTION DATA SUMMARY SHEET

N/S: W/E: I/S No:

AM/PM: Comments:

COUNT DATE: STUDY DATE: GROWTH FACTOR:

	NORTHBOUND			SOUTHBOUND			WESTBOUND			EASTBOUND		
	LT	TH	RT	LT	TH	RT	LT	TH	RT	LT	TH	RT
EXISTING	60	1960	300	250	2240	10	230	80	330	70	90	90
AMBIENT												
RELATED												
PROJECT												
TOTAL	60	1960	300	250	2240	10	230	80	330	70	90	90
LANE												
SIGNAL	Phasing Prot-Fix RTOR OLA			Phasing Prot-Fix RTOR Auto			Phasing Perm RTOR OLA			Phasing Perm RTOR OLA		

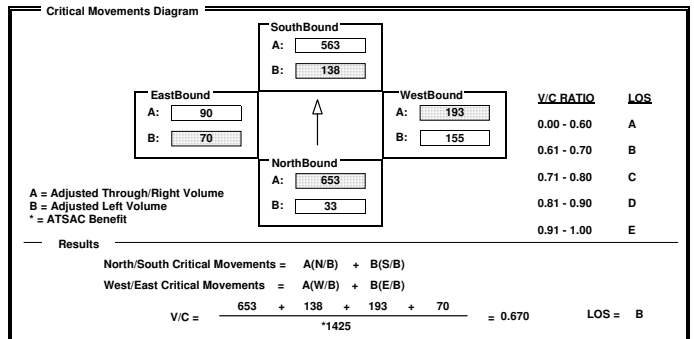

INTERSECTION DATA SUMMARY SHEET

N/S: W/E: I/S No:

AM/PM: Comments:

COUNT DATE: STUDY DATE: GROWTH FACTOR:

Volume/Lane/Signal Configurations

	NORTHBOUND			SOUTHBOUND			WESTBOUND			EASTBOUND		
	LT	TH	RT	LT	TH	RT	LT	TH	RT	LT	TH	RT
EXISTING	80	1290	180	200	1330	100	310	680	50	10	480	360
AMBIENT												
RELATED												
PROJECT												
TOTAL	80	1290	180	200	1330	100	310	680	50	10	480	360
LANE	1	3	1	1	2	1	2	1	1	1	1	1
SIGNAL	Prot-Fix OLA		Prot-Fix Auto		Prot-Fix <none>		Prot-Fix <none>		Perm Auto		Prot-Fix Auto	

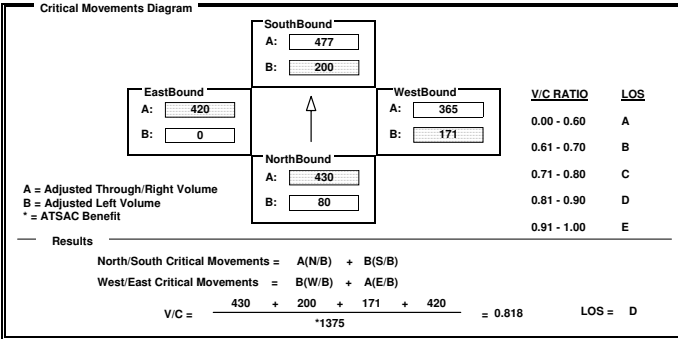

INTERSECTION DATA SUMMARY SHEET

N/S: W/E: I/S No:

AM/PM: Comments:

COUNT DATE: STUDY DATE: GROWTH FACTOR:

Volume/Lane/Signal Configurations

	NORTHBOUND			SOUTHBOUND			WESTBOUND			EASTBOUND		
	LT	TH	RT	LT	TH	RT	LT	TH	RT	LT	TH	RT
EXISTING	1130	1750	390	0	1860	20	0	0	20	0	0	1150
AMBIENT												
RELATED												
PROJECT												
TOTAL	1130	1750	390	0	1860	20	0	0	20	0	0	1150
LANE	4	2	1	3	1	1	1	1	1	1	1	4
SIGNAL	Prot-Fix Auto		<none> Auto		<none> Auto		<none> Auto		<none> Auto		Prot-Fix Auto	

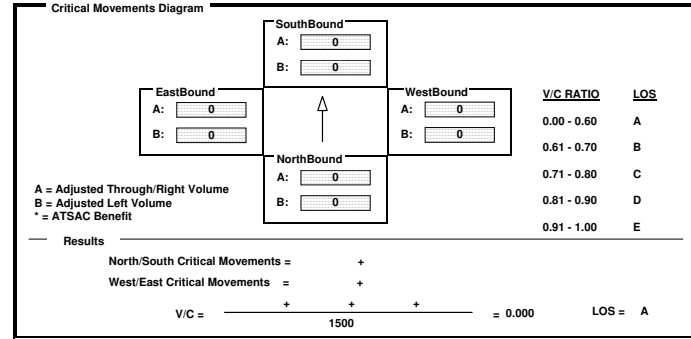

INTERSECTION DATA SUMMARY SHEET

N/S: W/E: I/S No:

AM/PM: Comments:

COUNT DATE: STUDY DATE: GROWTH FACTOR:

Volume/Lane/Signal Configurations

	NORTHBOUND			SOUTHBOUND			WESTBOUND			EASTBOUND		
	LT	TH	RT	LT	TH	RT	LT	TH	RT	LT	TH	RT
EXISTING	230	1640	160	300	1810	110	270	570	210	130	740	260
AMBIENT												
RELATED												
PROJECT												
TOTAL	230	1640	160	300	1810	110	270	570	210	130	740	260
LANE	2	2	1	2	2	1	2	2	1	2	3	1
SIGNAL	Prot-Fix Auto		Prot-Fix Auto		Prot-Fix OLA		Prot-Fix OLA		Prot-Fix OLA		Prot-Fix OLA	

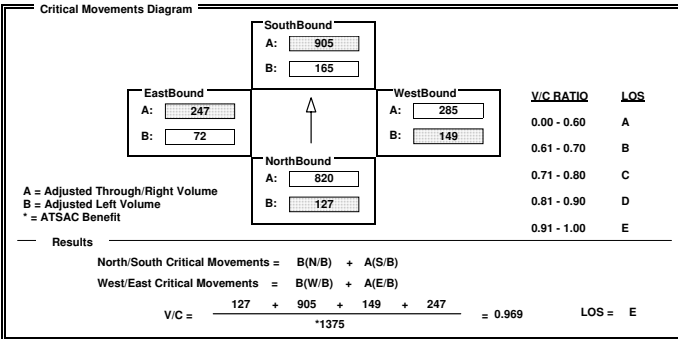

INTERSECTION DATA SUMMARY SHEET

N/S: W/E: I/S No:

AM/PM: Comments:

COUNT DATE: STUDY DATE: GROWTH FACTOR:

Volume/Lane/Signal Configurations

	NORTHBOUND			SOUTHBOUND			WESTBOUND			EASTBOUND		
	LT	TH	RT	LT	TH	RT	LT	TH	RT	LT	TH	RT
EXISTING	330	1600	400	330	1570	170	330	740	390	170	640	970
AMBIENT												
RELATED												
PROJECT												
TOTAL	330	1600	400	330	1570	170	330	740	390	170	640	970
LANE	2	2	1	2	2	1	2	2	1	2	2	1
SIGNAL	Prot-Fix Auto		Prot-Fix Auto		Prot-Fix OLA		Prot-Fix OLA		Prot-Fix OLA		Prot-Fix OLA	

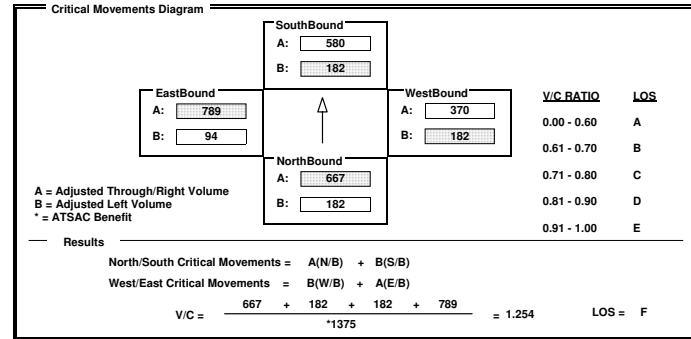

INTERSECTION DATA SUMMARY SHEET

N/S: W/E: I/S No:

AM/PM: Comments:

COUNT DATE: STUDY DATE: GROWTH FACTOR:

Volume/Lane/Signal Configurations

	NORTHBOUND			SOUTHBOUND			WESTBOUND			EASTBOUND		
	LT	TH	RT	LT	TH	RT	LT	TH	RT	LT	TH	RT
EXISTING	40	1300	30	160	1380	140	50	60	150	30	70	130
AMBIENT												
RELATED												
PROJECT												
TOTAL	40	1300	30	160	1380	140	50	60	150	30	70	130
LANE	1	2	1	1	1	1	1	1	1	2	1	1
SIGNAL	Phasing: Perm	RTOR: Auto		Phasing: Prot-Fix	RTOR: Auto		Phasing: Perm	RTOR: OLA		Phasing: Prot-Fix	RTOR: Auto	

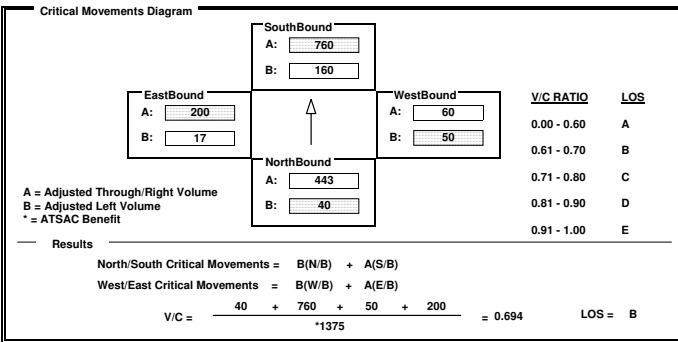

INTERSECTION DATA SUMMARY SHEET

N/S: W/E: I/S No:

AM/PM: Comments:

COUNT DATE: STUDY DATE: GROWTH FACTOR:

Volume/Lane/Signal Configurations

	NORTHBOUND			SOUTHBOUND			WESTBOUND			EASTBOUND		
	LT	TH	RT	LT	TH	RT	LT	TH	RT	LT	TH	RT
EXISTING	180	1080	150	240	1100	230	290	630	220	290	770	170
AMBIENT												
RELATED												
PROJECT												
TOTAL	180	1080	150	240	1100	230	290	630	220	290	770	170
LANE	1	3	1	1	3	1	1	2	1	2	2	1
SIGNAL	Phasing: Prot-Fix	RTOR: Auto		Phasing: Prot-Fix	RTOR: Auto		Phasing: Prot-Fix	RTOR: Auto		Phasing: Prot-Fix	RTOR: Auto	

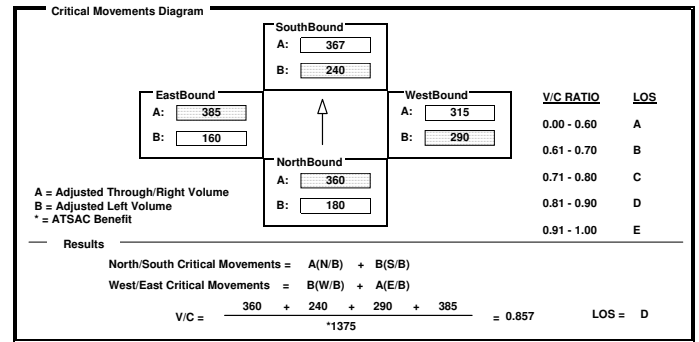

INTERSECTION DATA SUMMARY SHEET

N/S: W/E: I/S No:

AM/PM: Comments:

COUNT DATE: STUDY DATE: GROWTH FACTOR:

Volume/Lane/Signal Configurations

	NORTHBOUND			SOUTHBOUND			WESTBOUND			EASTBOUND		
	LT	TH	RT	LT	TH	RT	LT	TH	RT	LT	TH	RT
EXISTING	210	1460	100	100	1480	70	220	340	140	60	190	120
AMBIENT												
RELATED												
PROJECT												
TOTAL	210	1460	100	100	1480	70	220	340	140	60	190	120
LANE	1	3	1	1	3	1	1	1	1	1	2	1
SIGNAL	Phasing: Prot-Fix	RTOR: OLA		Phasing: Prot-Fix	RTOR: OLA		Phasing: Prot-Fix	RTOR: Auto		Phasing: Prot-Fix	RTOR: Auto	

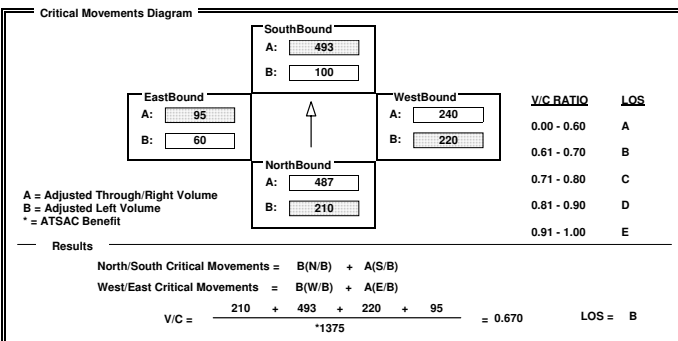

INTERSECTION DATA SUMMARY SHEET

N/S: W/E: I/S No:

AM/PM: Comments:

COUNT DATE: STUDY DATE: GROWTH FACTOR:

Volume/Lane/Signal Configurations

	NORTHBOUND			SOUTHBOUND			WESTBOUND			EASTBOUND		
	LT	TH	RT	LT	TH	RT	LT	TH	RT	LT	TH	RT
EXISTING	60	1560	40	80	1570	330	40	80	90	260	70	60
AMBIENT												
RELATED												
PROJECT												
TOTAL	60	1560	40	80	1570	330	40	80	90	260	70	60
LANE	1	3	1	1	2	1	0	1	1	2	1	1
SIGNAL	Phasing: Perm	RTOR: Auto		Phasing: Perm	RTOR: Auto		Phasing: Split	RTOR: Auto		Phasing: Split	RTOR: Auto	

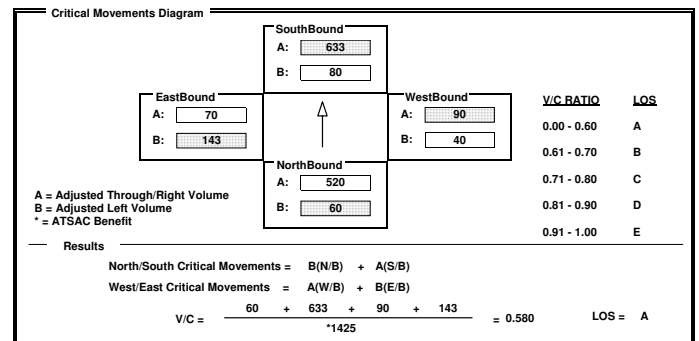

INTERSECTION DATA SUMMARY SHEET

N/S: Sepulveda Blvd W/E: 79 St/80th St I/S No: 137
AM/PM: MD Comments: Plus Project
COUNT DATE: STUDY DATE: GROWTH FACTOR:

Volume/Lane/Signal Configurations table with columns for Northbound, Southbound, Westbound, Eastbound and rows for Existing, Ambient, Related, Project, Total, Lane, and Signal.

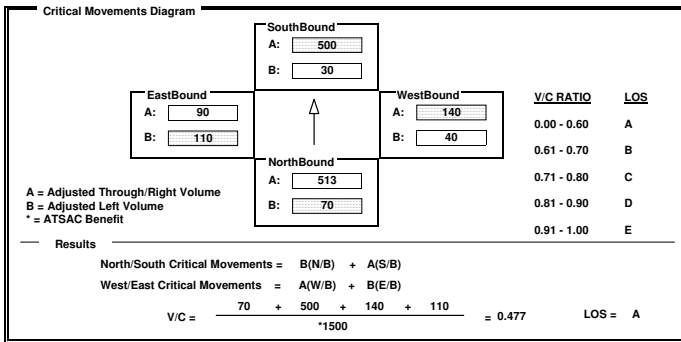

INTERSECTION DATA SUMMARY SHEET

N/S: Sepulveda Blvd W/E: 83rd St I/S No: 138
AM/PM: MD Comments: Plus Project
COUNT DATE: STUDY DATE: GROWTH FACTOR:

Volume/Lane/Signal Configurations table with columns for Northbound, Southbound, Westbound, Eastbound and rows for Existing, Ambient, Related, Project, Total, Lane, and Signal.

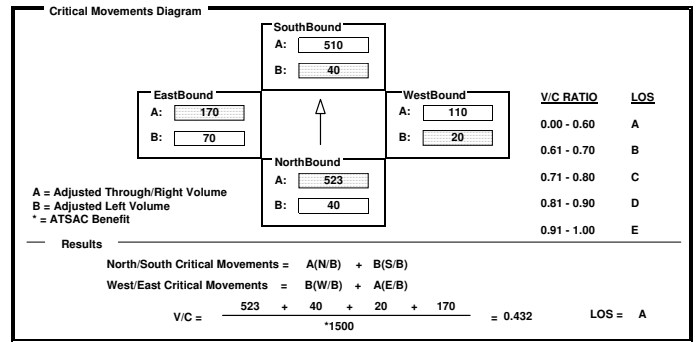

INTERSECTION DATA SUMMARY SHEET

N/S: Sepulveda Blvd W/E: I-105 WB Ramp I/S No: 139
AM/PM: MD Comments: Plus Project
COUNT DATE: STUDY DATE: GROWTH FACTOR:

Volume/Lane/Signal Configurations table with columns for Northbound, Southbound, Westbound, Eastbound and rows for Existing, Ambient, Related, Project, Total, Lane, and Signal.

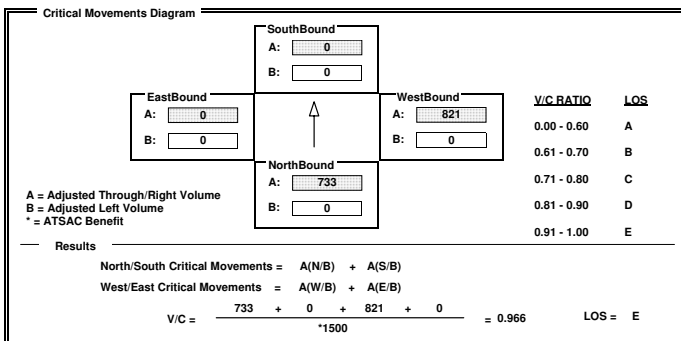

INTERSECTION DATA SUMMARY SHEET

N/S: Airport Blvd W/E: 96th St I/S No: 141
AM/PM: MD Comments: Plus Project
COUNT DATE: STUDY DATE: GROWTH FACTOR:

Volume/Lane/Signal Configurations table with columns for Northbound, Southbound, Westbound, Eastbound and rows for Existing, Ambient, Related, Project, Total, Lane, and Signal.

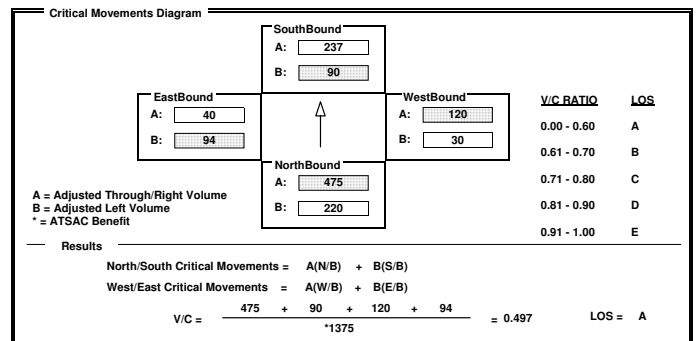

INTERSECTION DATA SUMMARY SHEET

N/S: W/E: I/S No:
 AM/PM: Comments:
 COUNT DATE: STUDY DATE: GROWTH FACTOR:

	NORTHBOUND			SOUTHBOUND			WESTBOUND			EASTBOUND		
	LT	TH	RT	LT	TH	RT	LT	TH	RT	LT	TH	RT
EXISTING	90	1070	70	90	760	110	50	50	150	190	80	120
AMBIENT												
RELATED												
PROJECT												
TOTAL	90	1070	70	90	760	110	50	50	150	190	80	120
LANE												
SIGNAL	Phasing		RTOR	Phasing		RTOR	Phasing		RTOR	Phasing		RTOR
	Perm		Auto	Perm		Auto	Perm		Auto	Perm		Auto

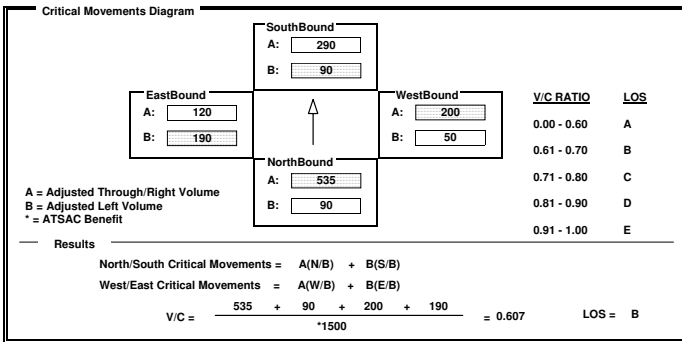

INTERSECTION DATA SUMMARY SHEET

N/S: W/E: I/S No:
 AM/PM: Comments:
 COUNT DATE: STUDY DATE: GROWTH FACTOR:

	NORTHBOUND			SOUTHBOUND			WESTBOUND			EASTBOUND		
	LT	TH	RT	LT	TH	RT	LT	TH	RT	LT	TH	RT
EXISTING	30	270	220	320	20	110	20	520	190	70	270	10
AMBIENT												
RELATED												
PROJECT												
TOTAL	30	270	220	320	20	110	20	520	190	70	270	10
LANE												
SIGNAL	Phasing		RTOR	Phasing		RTOR	Phasing		RTOR	Phasing		RTOR
	Perm		Auto	Perm		Auto	Perm		Auto	Perm		Auto

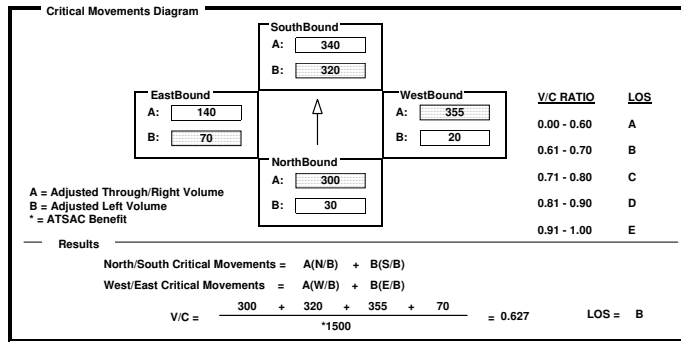

INTERSECTION DATA SUMMARY SHEET

N/S: W/E: I/S No:
 AM/PM: Comments:
 COUNT DATE: STUDY DATE: GROWTH FACTOR:

	NORTHBOUND			SOUTHBOUND			WESTBOUND			EASTBOUND		
	LT	TH	RT	LT	TH	RT	LT	TH	RT	LT	TH	RT
EXISTING	0	550	150	150	670	0	1010	0	90	0	0	0
AMBIENT												
RELATED												
PROJECT												
TOTAL	0	550	150	150	670	0	1010	0	90	0	0	0
LANE												
SIGNAL	Phasing		RTOR	Phasing		RTOR	Phasing		RTOR	Phasing		RTOR
	Perm		OLA	Prot-Fix		Auto	Split		Auto	Split		Auto

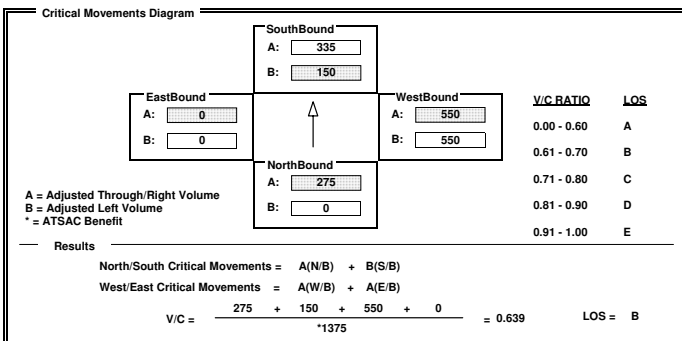

INTERSECTION DATA SUMMARY SHEET

N/S: W/E: I/S No:
 AM/PM: Comments:
 COUNT DATE: STUDY DATE: GROWTH FACTOR:

	NORTHBOUND			SOUTHBOUND			WESTBOUND			EASTBOUND		
	LT	TH	RT	LT	TH	RT	LT	TH	RT	LT	TH	RT
EXISTING	0	610	150	710	620	0	0	0	250	0	0	0
AMBIENT												
RELATED												
PROJECT												
TOTAL	0	610	150	710	620	0	0	0	250	0	0	0
LANE												
SIGNAL	Phasing		RTOR	Phasing		RTOR	Phasing		RTOR	Phasing		RTOR
	Perm		Auto	Prot-Fix		Auto	Split		OLA	Split		Auto

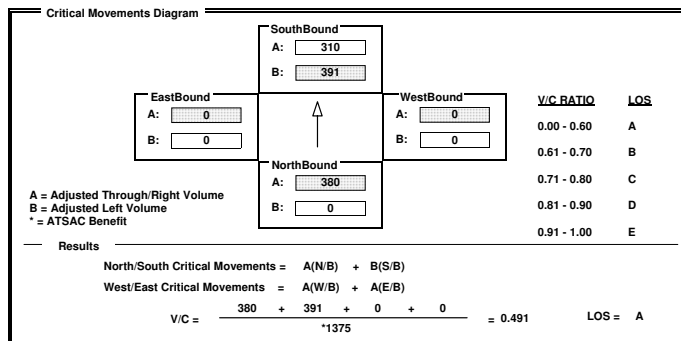

INTERSECTION DATA SUMMARY SHEET

N/S: W/E: I/S No:

AM/PM: Comments:

COUNT DATE: STUDY DATE: GROWTH FACTOR:

Volume/Lane/Signal Configurations

	NORTHBOUND			SOUTHBOUND			WESTBOUND			EASTBOUND		
	LT	TH	RT	LT	TH	RT	LT	TH	RT	LT	TH	RT
EXISTING	160	1940	130	140	1380	320	150	700	140	10	690	190
AMBIENT												
RELATED												
PROJECT												
TOTAL	160	1940	130	140	1380	320	150	700	140	10	690	190
LANE												
SIGNAL	Phasing		RTOR	Phasing		RTOR	Phasing		RTOR	Phasing		RTOR
	Prot-Fix		Auto	Prot-Fix		Auto	Prot-Fix		Auto	Perm		Auto

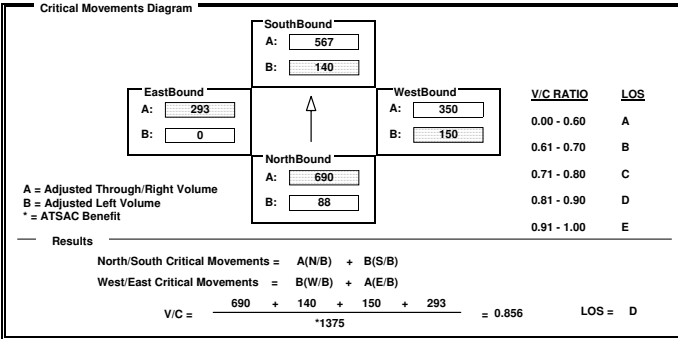

INTERSECTION DATA SUMMARY SHEET

N/S: W/E: I/S No:

AM/PM: Comments:

COUNT DATE: STUDY DATE: GROWTH FACTOR:

Volume/Lane/Signal Configurations

	NORTHBOUND			SOUTHBOUND			WESTBOUND			EASTBOUND		
	LT	TH	RT	LT	TH	RT	LT	TH	RT	LT	TH	RT
EXISTING	60	1060	190	130	880	130	230	1100	120	150	940	120
AMBIENT												
RELATED												
PROJECT												
TOTAL	60	1060	190	130	880	130	230	1100	120	150	940	120
LANE												
SIGNAL	Phasing		RTOR	Phasing		RTOR	Phasing		RTOR	Phasing		RTOR
	Perm		Auto	Prot-Fix		Auto	Prot-Fix		Auto	Prot-Fix		Auto

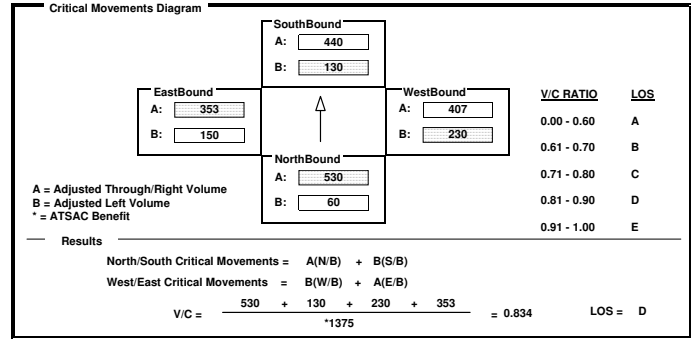

INTERSECTION DATA SUMMARY SHEET

N/S: W/E: I/S No:

AM/PM: Comments:

COUNT DATE: STUDY DATE: GROWTH FACTOR:

Volume/Lane/Signal Configurations

	NORTHBOUND			SOUTHBOUND			WESTBOUND			EASTBOUND		
	LT	TH	RT	LT	TH	RT	LT	TH	RT	LT	TH	RT
EXISTING	110	480	40	230	660	130	40	880	140	240	670	100
AMBIENT												
RELATED												
PROJECT												
TOTAL	110	480	40	230	660	130	40	880	140	240	670	100
LANE												
SIGNAL	Phasing		RTOR	Phasing		RTOR	Phasing		RTOR	Phasing		RTOR
	Prot-Fix		Auto	Prot-Fix		Auto	Prot-Fix		Auto	Prot-Fix		Auto

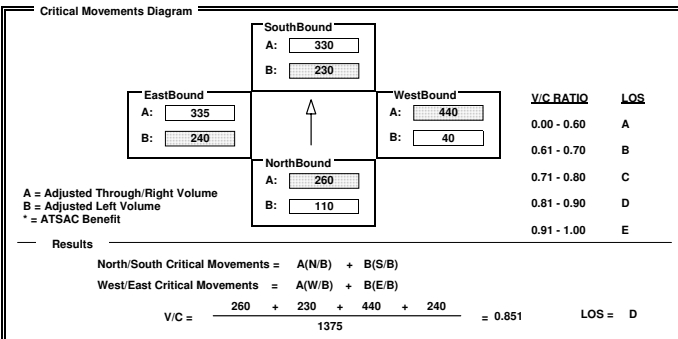

INTERSECTION DATA SUMMARY SHEET

N/S: W/E: I/S No:

AM/PM: Comments:

COUNT DATE: STUDY DATE: GROWTH FACTOR:

Volume/Lane/Signal Configurations

	NORTHBOUND			SOUTHBOUND			WESTBOUND			EASTBOUND		
	LT	TH	RT	LT	TH	RT	LT	TH	RT	LT	TH	RT
EXISTING	0	1840	700	140	0	0	680	0	60	0	0	0
AMBIENT												
RELATED												
PROJECT												
TOTAL	0	1840	700	140	0	0	680	0	60	0	0	0
LANE												
SIGNAL	Phasing		RTOR	Phasing		RTOR	Phasing		RTOR	Phasing		RTOR
	Prot-Fix		Auto	Prot-Fix		Auto	Split		Free	Prot-Fix		Auto

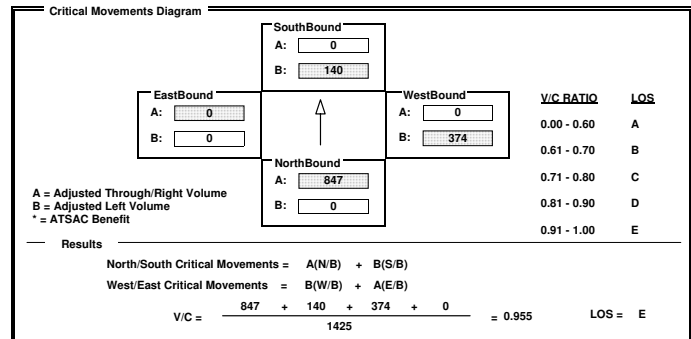

INTERSECTION DATA SUMMARY SHEET

N/S: Overland Ave W/E: Venice Blvd I/S No: 121
 AM/PM: MD Comments: Cumulative (2013) With Project
 COUNT DATE: STUDY DATE: GROWTH FACTOR:

	NORTHBOUND			SOUTHBOUND			WESTBOUND			EASTBOUND		
	LT	TH	RT	LT	TH	RT	LT	TH	RT	LT	TH	RT
EXISTING	140	790	160	90	570	210	220	1400	190	170	1170	80
AMBIENT												
RELATED												
PROJECT												
TOTAL	140	790	160	90	570	210	220	1400	190	170	1170	80
LANE	1	2	1	1	2	1	2	2	1	2	2	1
SIGNAL	Prot-Fix	OLA	Prot-Fix	OLA	Prot-Fix	Auto	Prot-Fix	Auto	Prot-Fix	Auto	Prot-Fix	Auto

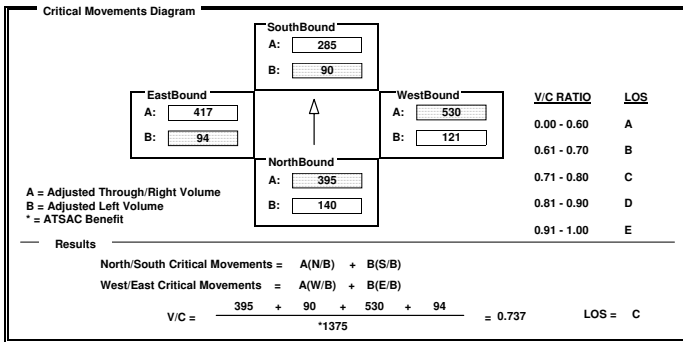

INTERSECTION DATA SUMMARY SHEET

N/S: Lincoln Blvd W/E: Rose Ave I/S No: 160
 AM/PM: MD Comments: Cumulative (2013) With Project
 COUNT DATE: STUDY DATE: GROWTH FACTOR:

	NORTHBOUND			SOUTHBOUND			WESTBOUND			EASTBOUND		
	LT	TH	RT	LT	TH	RT	LT	TH	RT	LT	TH	RT
EXISTING	130	1460	40	90	1390	210	100	240	110	280	260	190
AMBIENT												
RELATED												
PROJECT												
TOTAL	130	1460	40	90	1390	210	100	240	110	280	260	190
LANE	1	2	1	1	2	1	1	1	1	1	1	1
SIGNAL	Perm	Auto	Perm	Auto	Perm	Auto	Perm	Auto	Perm	Auto	Perm	Auto

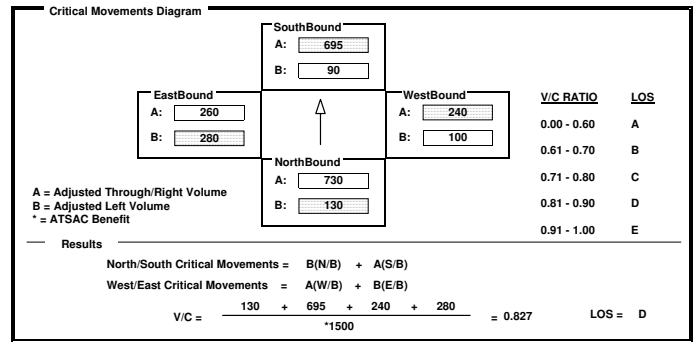

INTERSECTION DATA SUMMARY SHEET

N/S: Western Ave W/E: Century Blvd I/S No: 161
 AM/PM: MD Comments: Cumulative (2013) With Project
 COUNT DATE: STUDY DATE: GROWTH FACTOR:

	NORTHBOUND			SOUTHBOUND			WESTBOUND			EASTBOUND		
	LT	TH	RT	LT	TH	RT	LT	TH	RT	LT	TH	RT
EXISTING	100	570	130	80	490	110	100	790	110	150	820	110
AMBIENT												
RELATED												
PROJECT												
TOTAL	100	570	130	80	490	110	100	790	110	150	820	110
LANE	1	2	1	1	1	1	1	2	1	1	2	1
SIGNAL	Prot-Fix	OLA	Prot-Fix	Auto	Prot-Fix	Auto	Prot-Fix	Auto	Prot-Fix	Auto	Prot-Fix	Auto

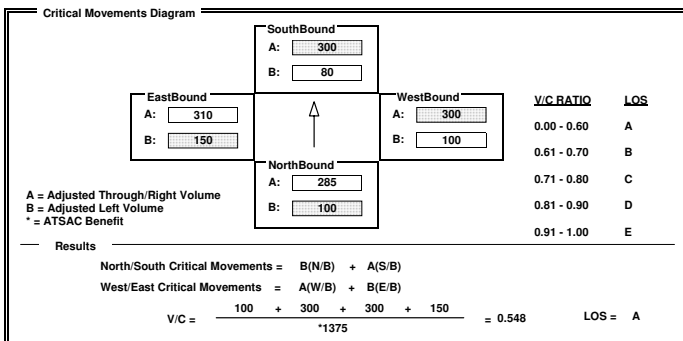

INTERSECTION DATA SUMMARY SHEET

N/S: La Cienega Blvd W/E: Jefferson Blvd I/S No: 200
 AM/PM: MD Comments: Cumulative (2013) With Project
 COUNT DATE: STUDY DATE: GROWTH FACTOR:

	NORTHBOUND			SOUTHBOUND			WESTBOUND			EASTBOUND		
	LT	TH	RT	LT	TH	RT	LT	TH	RT	LT	TH	RT
EXISTING	0	0	0	0	0	0	0	0	0	0	0	0
AMBIENT												
RELATED												
PROJECT												
TOTAL	0	0	0	0	0	0	0	0	0	0	0	0
LANE	1	2	1	1	3	1	2	2	1	2	1	1
SIGNAL	Perm	Auto	Perm	OLA	Prot-Fix	Auto	Prot-Fix	Auto	Prot-Fix	Auto	Prot-Fix	Auto

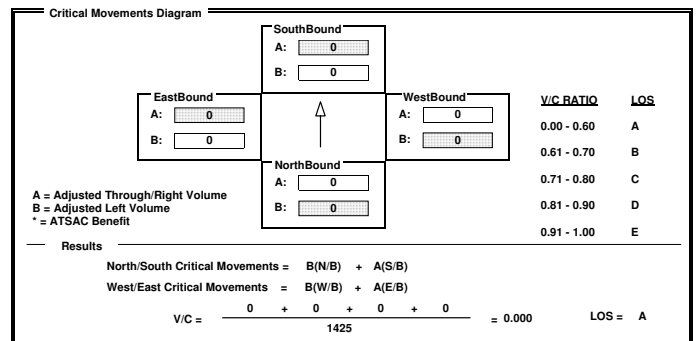

INTERSECTION DATA SUMMARY SHEET

N/S: Airport Blvd W/E: Westchester Blvd I/S No: 6
AM/PM: PM Comments: Plus Project
COUNT DATE: STUDY DATE: GROWTH FACTOR:

Volume/Lane/Signal Configurations table with columns for Northbound, Southbound, Westbound, Eastbound and rows for Existing, Ambient, Related, Project, Total, Lane, Phasing, RTOR, Signal.

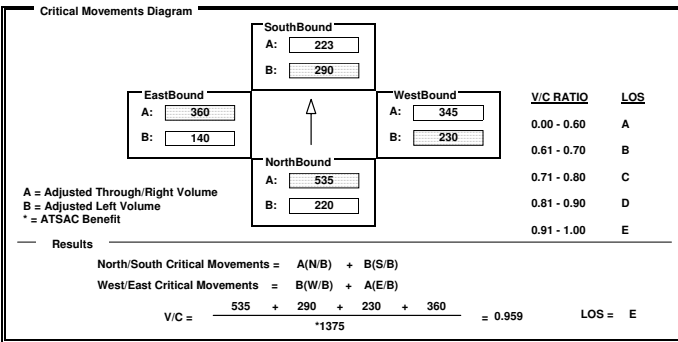

INTERSECTION DATA SUMMARY SHEET

N/S: Airport Blvd W/E: Century Blvd I/S No: 7
AM/PM: PM Comments: Plus Project
COUNT DATE: STUDY DATE: GROWTH FACTOR:

Volume/Lane/Signal Configurations table with columns for Northbound, Southbound, Westbound, Eastbound and rows for Existing, Ambient, Related, Project, Total, Lane, Phasing, RTOR, Signal.

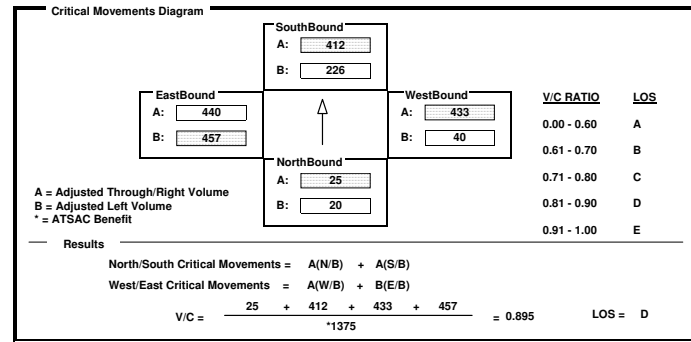

INTERSECTION DATA SUMMARY SHEET

N/S: Airport Blvd W/E: La Tijera Blvd I/S No: 8
AM/PM: PM Comments: Plus Project
COUNT DATE: STUDY DATE: GROWTH FACTOR:

Volume/Lane/Signal Configurations table with columns for Northbound, Southbound, Westbound, Eastbound and rows for Existing, Ambient, Related, Project, Total, Lane, Phasing, RTOR, Signal.

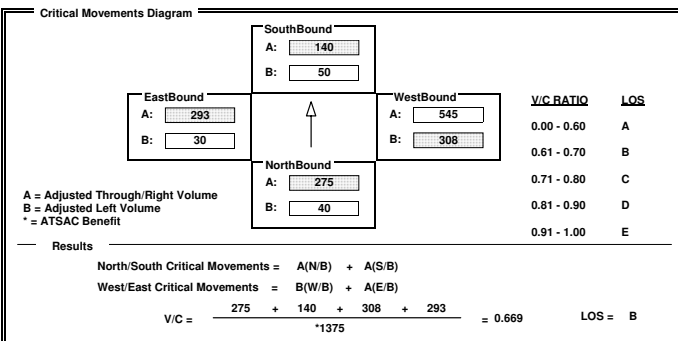

INTERSECTION DATA SUMMARY SHEET

N/S: Airport Blvd W/E: Manchester Ave I/S No: 9
AM/PM: PM Comments: Plus Project
COUNT DATE: STUDY DATE: GROWTH FACTOR:

Volume/Lane/Signal Configurations table with columns for Northbound, Southbound, Westbound, Eastbound and rows for Existing, Ambient, Related, Project, Total, Lane, Phasing, RTOR, Signal.

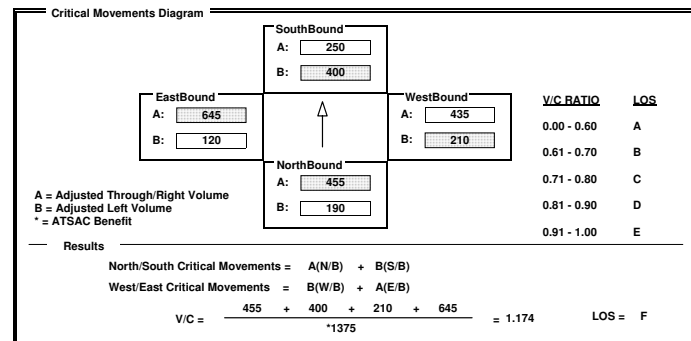

INTERSECTION DATA SUMMARY SHEET

N/S: W/E: I/S No:

AM/PM: Comments:

COUNT DATE: STUDY DATE: GROWTH FACTOR:

Volume/Lane/Signal Configurations

	NORTHBOUND			SOUTHBOUND			WESTBOUND			EASTBOUND		
	LT	TH	RT	LT	TH	RT	LT	TH	RT	LT	TH	RT
EXISTING	250	740	130	110	460	150	110	520	70	150	1220	320
AMBIENT												
RELATED												
PROJECT												
TOTAL	250	740	130	110	460	150	110	520	70	150	1220	320
LANE	1	2	1	1	1	1	1	1	1	1	1	1
SIGNAL	Phasing: Perm	RTOR: Auto		Phasing: Perm	RTOR: Auto		Phasing: Perm	RTOR: Auto		Phasing: Perm	RTOR: Auto	

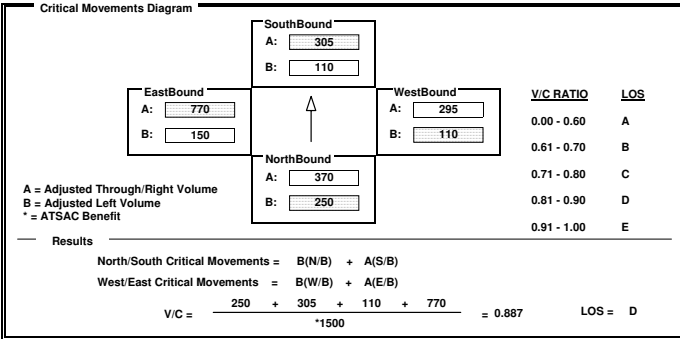

INTERSECTION DATA SUMMARY SHEET

N/S: W/E: I/S No:

AM/PM: Comments:

COUNT DATE: STUDY DATE: GROWTH FACTOR:

Volume/Lane/Signal Configurations

	NORTHBOUND			SOUTHBOUND			WESTBOUND			EASTBOUND		
	LT	TH	RT	LT	TH	RT	LT	TH	RT	LT	TH	RT
EXISTING	560	680	90	170	540	190	110	1630	140	250	1930	500
AMBIENT												
RELATED												
PROJECT												
TOTAL	560	680	90	170	540	190	110	1630	140	250	1930	500
LANE	2	1	1	2	2	1	1	3	1	1	3	1
SIGNAL	Phasing: Prot-Fix	RTOR: Auto		Phasing: Prot-Fix	RTOR: OLA		Phasing: Prot-Fix	RTOR: Auto		Phasing: Prot-Fix	RTOR: Auto	

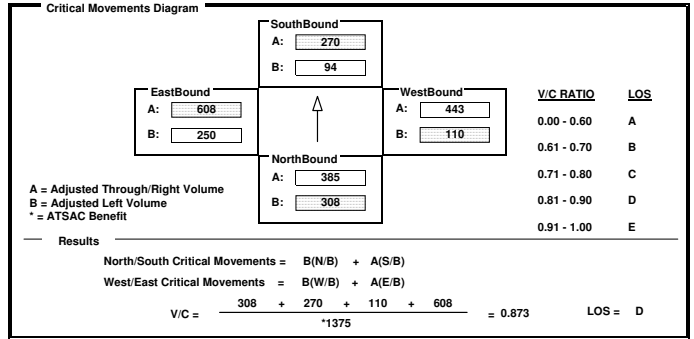

INTERSECTION DATA SUMMARY SHEET

N/S: W/E: I/S No:

AM/PM: Comments:

COUNT DATE: STUDY DATE: GROWTH FACTOR:

Volume/Lane/Signal Configurations

	NORTHBOUND			SOUTHBOUND			WESTBOUND			EASTBOUND		
	LT	TH	RT	LT	TH	RT	LT	TH	RT	LT	TH	RT
EXISTING	220	610	610	450	780	110	410	450	370	230	1110	380
AMBIENT												
RELATED												
PROJECT												
TOTAL	220	610	610	450	780	110	410	450	370	230	1110	380
LANE	2	2	1	2	2	1	2	3	1	2	2	1
SIGNAL	Phasing: Prot-Fix	RTOR: OLA		Phasing: Prot-Fix	RTOR: OLA		Phasing: Prot-Fix	RTOR: OLA		Phasing: Prot-Fix	RTOR: Auto	

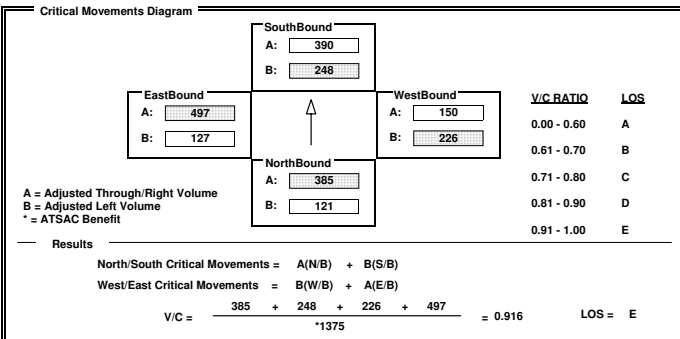

INTERSECTION DATA SUMMARY SHEET

N/S: W/E: I/S No:

AM/PM: Comments:

COUNT DATE: STUDY DATE: GROWTH FACTOR:

Volume/Lane/Signal Configurations

	NORTHBOUND			SOUTHBOUND			WESTBOUND			EASTBOUND		
	LT	TH	RT	LT	TH	RT	LT	TH	RT	LT	TH	RT
EXISTING	360	1470	30	60	1530	360	10	10	30	350	10	130
AMBIENT												
RELATED												
PROJECT												
TOTAL	360	1470	30	60	1530	360	10	10	30	350	10	130
LANE	1	2	1	1	2	1				1	1	1
SIGNAL	Phasing: Prot-Fix	RTOR: Auto		Phasing: Prot-Fix	RTOR: Auto		Phasing: Prot-Fix	RTOR: Auto		Phasing: Prot-Fix	RTOR: Auto	

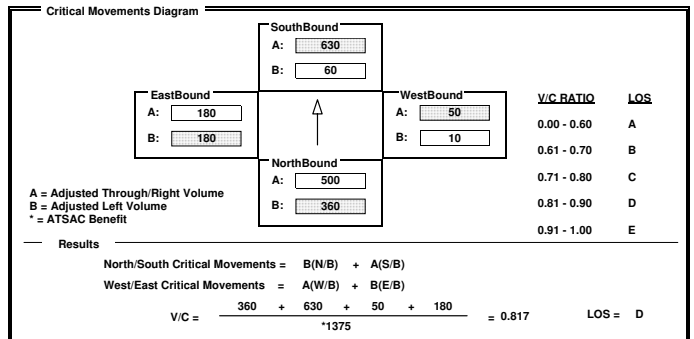

INTERSECTION DATA SUMMARY SHEET

N/S: Lincoln Blv W/E: Bluff Creek Dr I/S No: 22
AM/PM: PM Comments: Plus Project
COUNT DATE: STUDY DATE: GROWTH FACTOR:

Volume/Lane/Signal Configurations table with columns for Northbound, Southbound, Westbound, Eastbound and rows for Existing, Ambient, Related, Project, Total, Lane, and Signal.

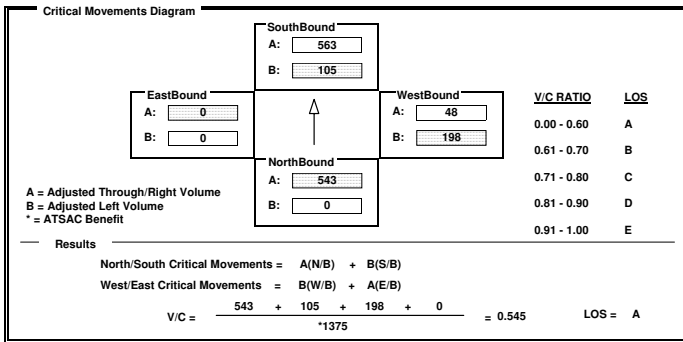

INTERSECTION DATA SUMMARY SHEET

N/S: La Tijera Blvd W/E: Centinela Ave I/S No: 27
AM/PM: PM Comments: Plus Project
COUNT DATE: STUDY DATE: GROWTH FACTOR:

Volume/Lane/Signal Configurations table with columns for Northbound, Southbound, Westbound, Eastbound and rows for Existing, Ambient, Related, Project, Total, Lane, and Signal.

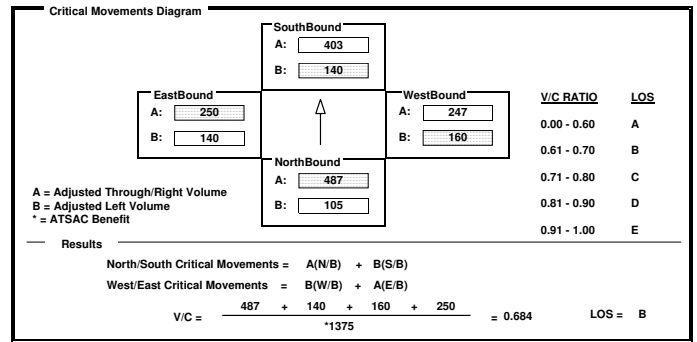

INTERSECTION DATA SUMMARY SHEET

N/S: La Cienega Blvd W/E: Century Blvd I/S No: 36
AM/PM: PM Comments: Plus Project
COUNT DATE: STUDY DATE: GROWTH FACTOR:

Volume/Lane/Signal Configurations table with columns for Northbound, Southbound, Westbound, Eastbound and rows for Existing, Ambient, Related, Project, Total, Lane, and Signal.

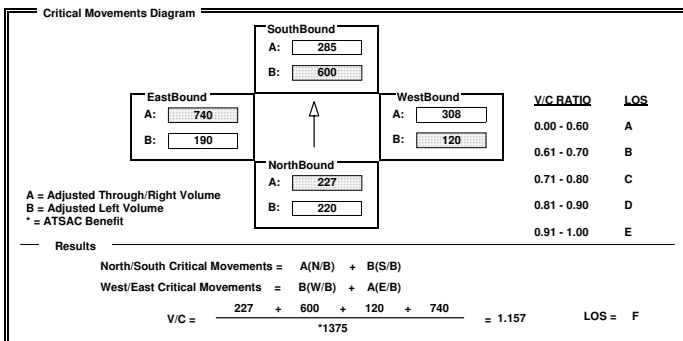

INTERSECTION DATA SUMMARY SHEET

N/S: Sepulveda Blvd W/E: Century Blvd I/S No: 38
AM/PM: PM Comments: Plus Project
COUNT DATE: STUDY DATE: GROWTH FACTOR:

Volume/Lane/Signal Configurations table with columns for Northbound, Southbound, Westbound, Eastbound and rows for Existing, Ambient, Related, Project, Total, Lane, and Signal.

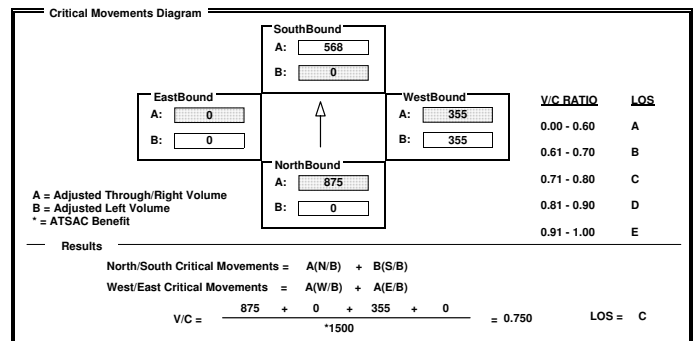

INTERSECTION DATA SUMMARY SHEET

N/S: Douglas St W/E: Imperial Hwy I/S No: 47
AM/PM: PM Comments: Plus Project
COUNT DATE: STUDY DATE: GROWTH FACTOR:

Volume/Lane/Signal Configurations table with columns for Northbound, Southbound, Westbound, Eastbound and rows for Existing, Ambient, Related, Project, Total, Lane, and Signal.

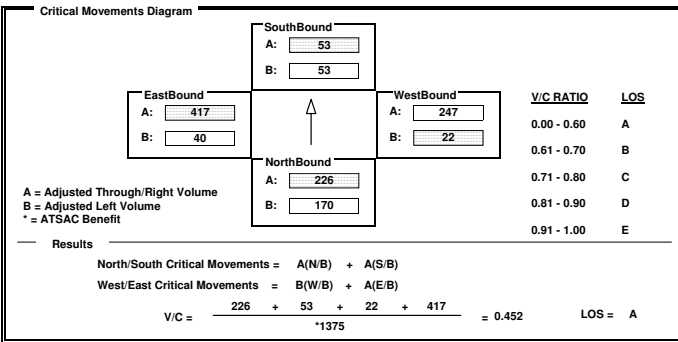

INTERSECTION DATA SUMMARY SHEET

N/S: Lincoln Blvd W/E: Fiji Way I/S No: 56
AM/PM: PM Comments: Plus Project
COUNT DATE: STUDY DATE: GROWTH FACTOR:

Volume/Lane/Signal Configurations table with columns for Northbound, Southbound, Westbound, Eastbound and rows for Existing, Ambient, Related, Project, Total, Lane, and Signal.

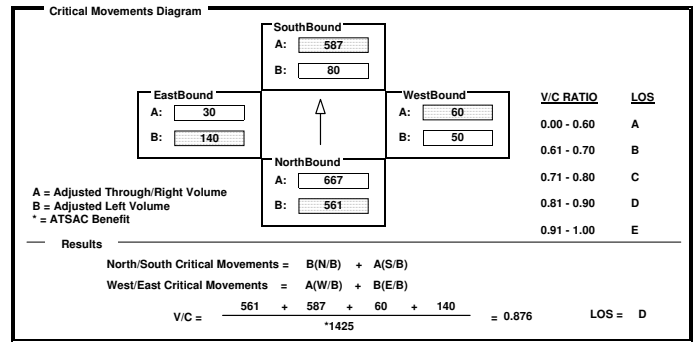

INTERSECTION DATA SUMMARY SHEET

N/S: Sepulveda Blvd W/E: Howard Hughes Pkwy I/S No: 65
AM/PM: PM Comments: Plus Project
COUNT DATE: STUDY DATE: GROWTH FACTOR:

Volume/Lane/Signal Configurations table with columns for Northbound, Southbound, Westbound, Eastbound and rows for Existing, Ambient, Related, Project, Total, Lane, and Signal.

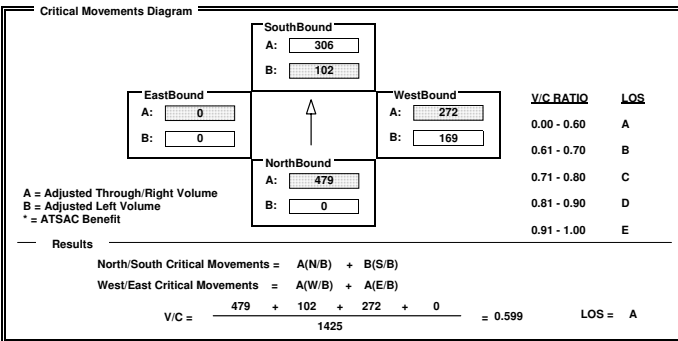

INTERSECTION DATA SUMMARY SHEET

N/S: La Cienega Blvd W/E: Imperial Hwy I/S No: 67
AM/PM: PM Comments: Plus Project
COUNT DATE: STUDY DATE: GROWTH FACTOR:

Volume/Lane/Signal Configurations table with columns for Northbound, Southbound, Westbound, Eastbound and rows for Existing, Ambient, Related, Project, Total, Lane, and Signal.

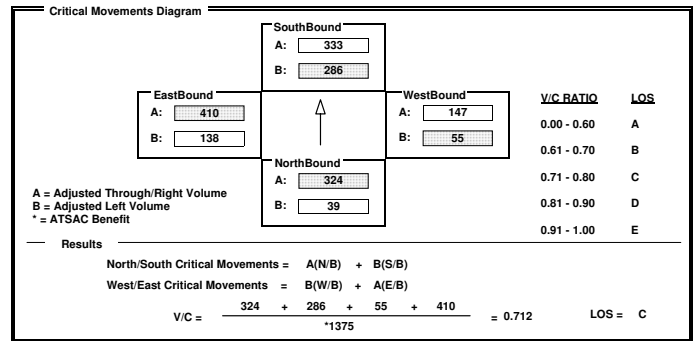

INTERSECTION DATA SUMMARY SHEET

N/S: Sepulveda Blvd W/E: Imperial Hwy I/S No: 71
AM/PM: PM Comments: Plus Project
COUNT DATE: STUDY DATE: GROWTH FACTOR:

Volume/Lane/Signal Configurations table with columns for Northbound, Southbound, Westbound, Eastbound and rows for Existing, Ambient, Related, Project, Total, Lane, Phasing, RTOR, Signal.

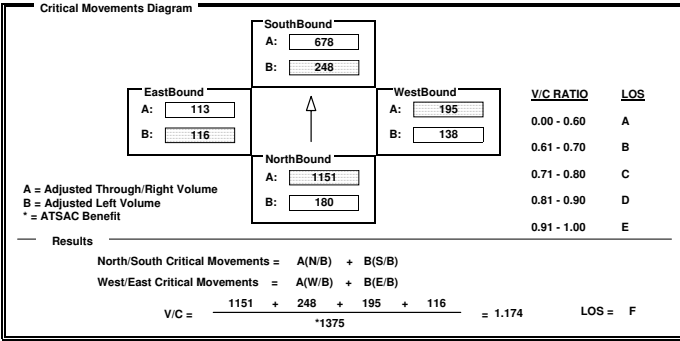

INTERSECTION DATA SUMMARY SHEET

N/S: 105 WB Off Ramps/Nash St W/E: Imperial Hwy I/S No: 73
AM/PM: PM Comments: Plus Project
COUNT DATE: STUDY DATE: GROWTH FACTOR:

Volume/Lane/Signal Configurations table with columns for Northbound, Southbound, Westbound, Eastbound and rows for Existing, Ambient, Related, Project, Total, Lane, Phasing, RTOR, Signal.

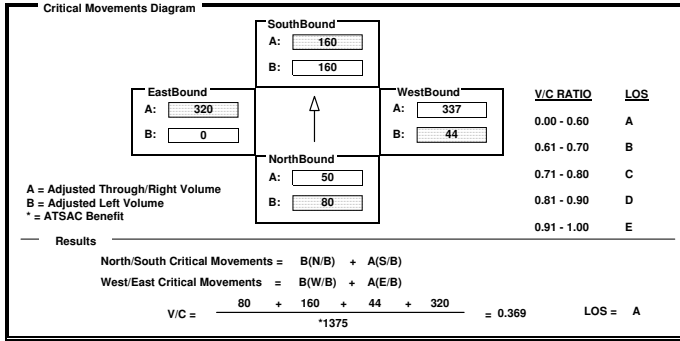

INTERSECTION DATA SUMMARY SHEET

N/S: 105 EB On Ramps W/E: Imperial Hwy I/S No: 74
AM/PM: PM Comments: Plus Project
COUNT DATE: STUDY DATE: GROWTH FACTOR:

Volume/Lane/Signal Configurations table with columns for Northbound, Southbound, Westbound, Eastbound and rows for Existing, Ambient, Related, Project, Total, Lane, Phasing, RTOR, Signal.

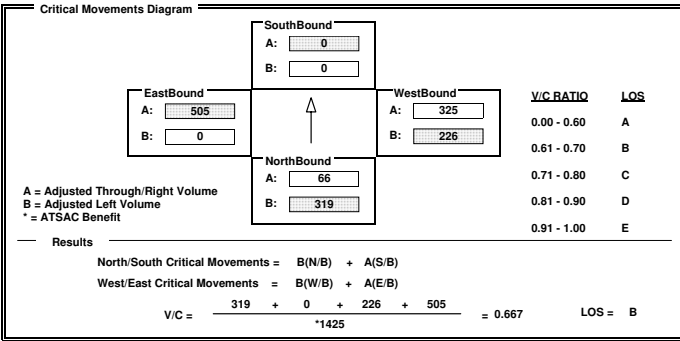

INTERSECTION DATA SUMMARY SHEET

N/S: Lincoln Blvd W/E: Jefferson Blvd I/S No: 78
AM/PM: PM Comments: Plus Project
COUNT DATE: STUDY DATE: GROWTH FACTOR:

Volume/Lane/Signal Configurations table with columns for Northbound, Southbound, Westbound, Eastbound and rows for Existing, Ambient, Related, Project, Total, Lane, Phasing, RTOR, Signal.

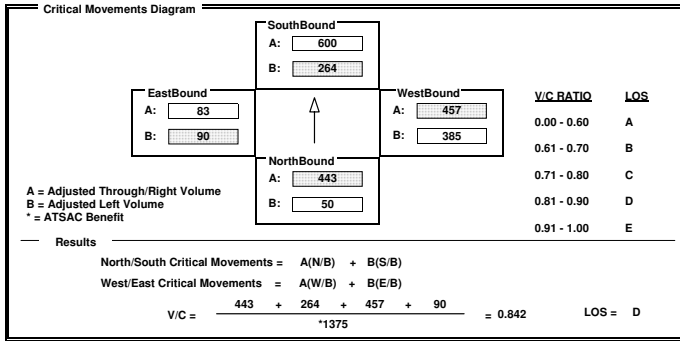

INTERSECTION DATA SUMMARY SHEET

N/S: W/E: I/S No:

AM/PM: Comments:

COUNT DATE: STUDY DATE: GROWTH FACTOR:

	NORTHBOUND			SOUTHBOUND			WESTBOUND			EASTBOUND		
	LT	TH	RT	LT	TH	RT	LT	TH	RT	LT	TH	RT
EXISTING	0	2320	210	0	2710	1390	0	0	0	1100	260	30
AMBIENT												
RELATED												
PROJECT												
TOTAL	0	2320	210	0	2710	1390	0	0	0	1100	260	30
LANE	1 2 1			1 3 1			1 1 1			3 1 1		
SIGNAL	Phasing: Perm		RTOR: Auto	Phasing: Perm		RTOR: OLA	Phasing: <none>		RTOR: <none>	Phasing: Split		RTOR: Auto

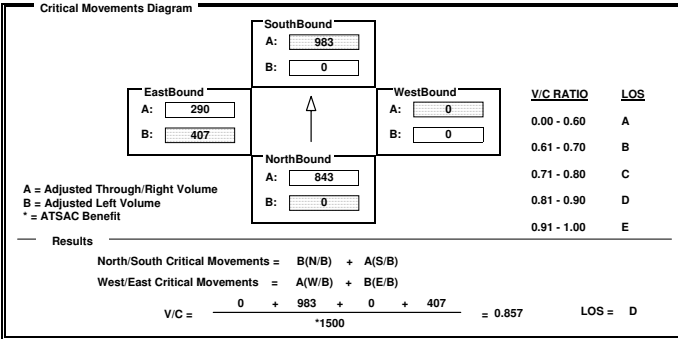

INTERSECTION DATA SUMMARY SHEET

N/S: W/E: I/S No:

AM/PM: Comments:

COUNT DATE: STUDY DATE: GROWTH FACTOR:

	NORTHBOUND			SOUTHBOUND			WESTBOUND			EASTBOUND		
	LT	TH	RT	LT	TH	RT	LT	TH	RT	LT	TH	RT
EXISTING	40	1730	20	40	1700	140	20	10	10	30	20	60
AMBIENT												
RELATED												
PROJECT												
TOTAL	40	1730	20	40	1700	140	20	10	10	30	20	60
LANE	2 2 1			1 2 1			1 1 1			1 1 1		
SIGNAL	Phasing: Prot-Fix		RTOR: Auto	Phasing: Prot-Fix		RTOR: Auto	Phasing: Perm		RTOR: Auto	Phasing: Perm		RTOR: OLA

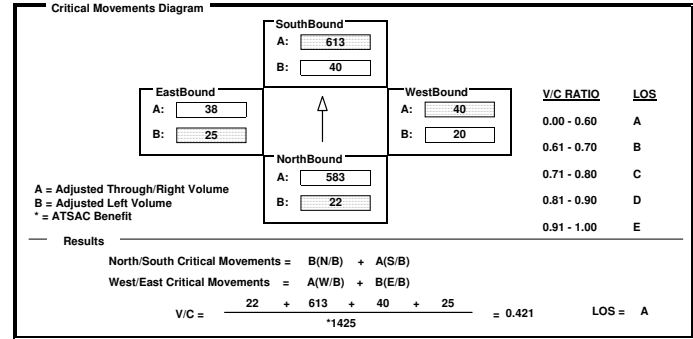

INTERSECTION DATA SUMMARY SHEET

N/S: W/E: I/S No:

AM/PM: Comments:

COUNT DATE: STUDY DATE: GROWTH FACTOR:

	NORTHBOUND			SOUTHBOUND			WESTBOUND			EASTBOUND		
	LT	TH	RT	LT	TH	RT	LT	TH	RT	LT	TH	RT
EXISTING	160	270	430	180	560	330	290	780	170	350	1070	180
AMBIENT												
RELATED												
PROJECT												
TOTAL	160	270	430	180	560	330	290	780	170	350	1070	180
LANE	1 2 1			1 2 1			1 2 1			1 2 1		
SIGNAL	Phasing: Prot-Fix		RTOR: Auto	Phasing: Prot-Fix		RTOR: Auto	Phasing: Prot-Fix		RTOR: Auto	Phasing: Prot-Fix		RTOR: Free

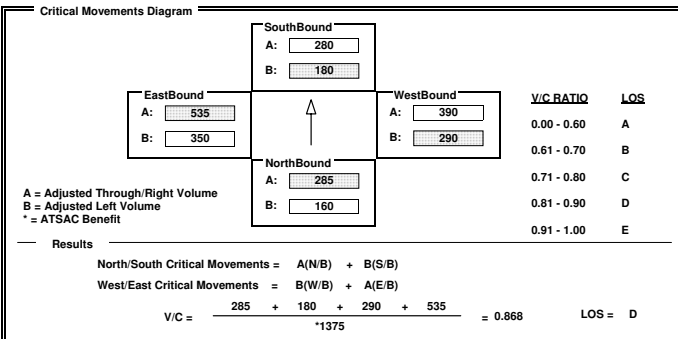

INTERSECTION DATA SUMMARY SHEET

N/S: W/E: I/S No:

AM/PM: Comments:

COUNT DATE: STUDY DATE: GROWTH FACTOR:

	NORTHBOUND			SOUTHBOUND			WESTBOUND			EASTBOUND		
	LT	TH	RT	LT	TH	RT	LT	TH	RT	LT	TH	RT
EXISTING	200	1700	190	110	1350	90	440	390	60	90	450	100
AMBIENT												
RELATED												
PROJECT												
TOTAL	200	1700	190	110	1350	90	440	390	60	90	450	100
LANE	1 3 1			1 3 1			1 2 1			1 2 1		
SIGNAL	Phasing: Prot-Fix		RTOR: OLA	Phasing: Prot-Fix		RTOR: OLA	Phasing: Perm		RTOR: Auto	Phasing: Prot-Fix		RTOR: OLA

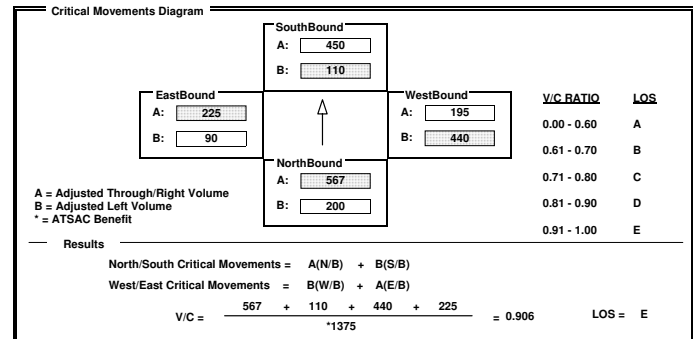

INTERSECTION DATA SUMMARY SHEET

N/S: 405 NB Ramps W/E: La Tijera Blvd I/S No: 102
AM/PM: PM Comments: Plus Project
COUNT DATE: STUDY DATE: GROWTH FACTOR:

Volume/Lane/Signal Configurations table with columns for Northbound, Southbound, Westbound, Eastbound and rows for Existing, Ambient, Related, Project, Total, Lane, and Signal.

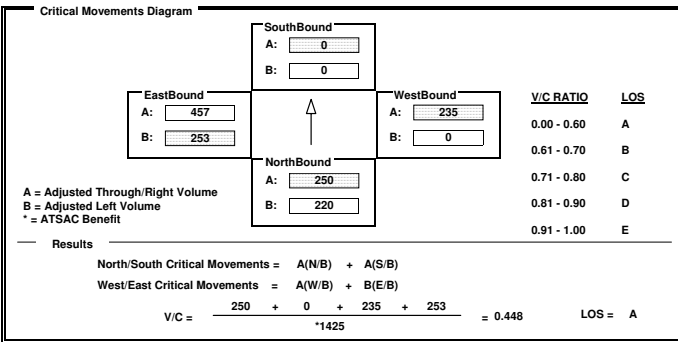

INTERSECTION DATA SUMMARY SHEET

N/S: La Tijera Blvd W/E: 405 SB Ramps I/S No: 103
AM/PM: PM Comments: Plus Project
COUNT DATE: STUDY DATE: GROWTH FACTOR:

Volume/Lane/Signal Configurations table with columns for Northbound, Southbound, Westbound, Eastbound and rows for Existing, Ambient, Related, Project, Total, Lane, and Signal.

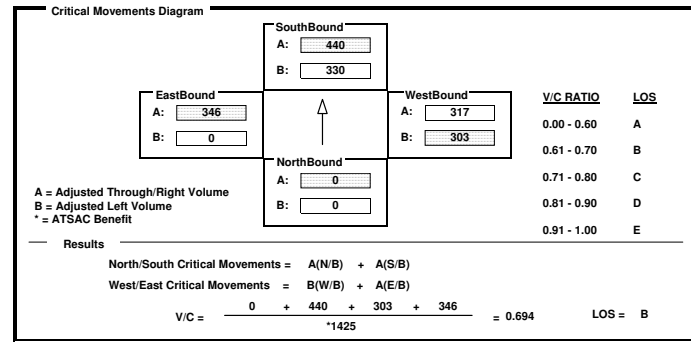

INTERSECTION DATA SUMMARY SHEET

N/S: Lincoln Blvd W/E: LMU Dr I/S No: 104
AM/PM: PM Comments: Plus Project
COUNT DATE: STUDY DATE: GROWTH FACTOR:

Volume/Lane/Signal Configurations table with columns for Northbound, Southbound, Westbound, Eastbound and rows for Existing, Ambient, Related, Project, Total, Lane, and Signal.

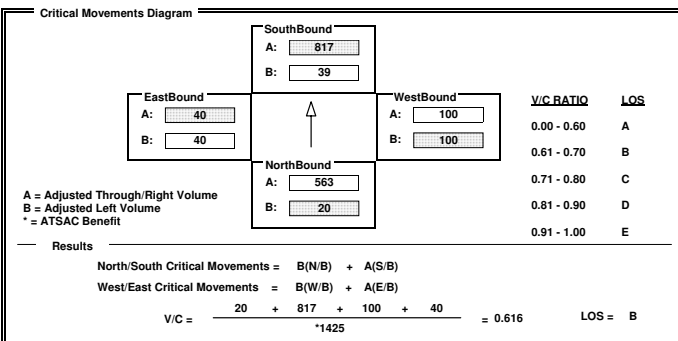

INTERSECTION DATA SUMMARY SHEET

N/S: Lincoln Blvd W/E: Manchester Blvd I/S No: 105
AM/PM: PM Comments: Plus Project
COUNT DATE: STUDY DATE: GROWTH FACTOR:

Volume/Lane/Signal Configurations table with columns for Northbound, Southbound, Westbound, Eastbound and rows for Existing, Ambient, Related, Project, Total, Lane, and Signal.

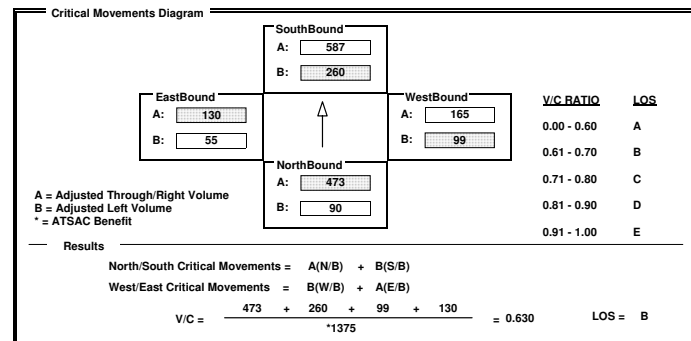

INTERSECTION DATA SUMMARY SHEET

N/S: W/E: I/S No:

AM/PM: Comments:

COUNT DATE: STUDY DATE: GROWTH FACTOR:

	NORTHBOUND			SOUTHBOUND			WESTBOUND			EASTBOUND		
	LT	TH	RT	LT	TH	RT	LT	TH	RT	LT	TH	RT
EXISTING	350	2140	250	230	2310	70	220	100	260	70	60	70
AMBIENT												
RELATED												
PROJECT												
TOTAL	350	2140	250	230	2310	70	220	100	260	70	60	70
LANE	2	3	1	2	3	1	1	1	1	1	1	1
Phasing	Prot-Fix		OLA	Prot-Fix		Auto	Perm		OLA	Perm		OLA
SIGNAL	Prot-Fix		OLA	Prot-Fix		Auto	Perm		OLA	Perm		OLA

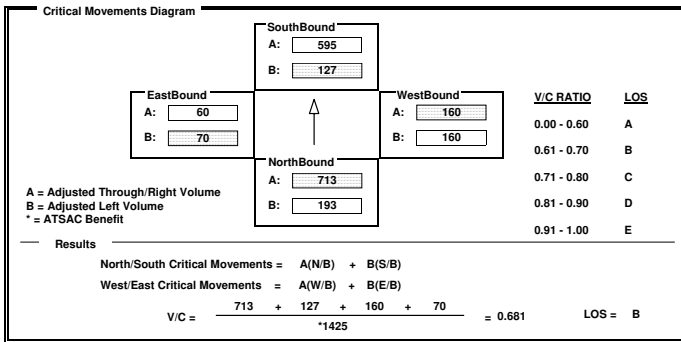

INTERSECTION DATA SUMMARY SHEET

N/S: W/E: I/S No:

AM/PM: Comments:

COUNT DATE: STUDY DATE: GROWTH FACTOR:

	NORTHBOUND			SOUTHBOUND			WESTBOUND			EASTBOUND		
	LT	TH	RT	LT	TH	RT	LT	TH	RT	LT	TH	RT
EXISTING	260	1640	300	280	1240	100	350	650	150	20	490	150
AMBIENT												
RELATED												
PROJECT												
TOTAL	260	1640	300	280	1240	100	350	650	150	20	490	150
LANE	1	3	1	1	2	1	2	1	1	1	1	1
Phasing	Prot-Fix		OLA	Prot-Fix		Auto	Prot-Fix		<none>	Perm		Auto
SIGNAL	Prot-Fix		OLA	Prot-Fix		Auto	Prot-Fix		<none>	Perm		Auto

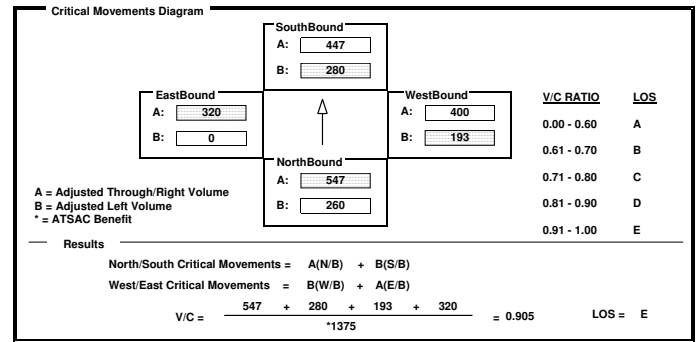

INTERSECTION DATA SUMMARY SHEET

N/S: W/E: I/S No:

AM/PM: Comments:

COUNT DATE: STUDY DATE: GROWTH FACTOR:

	NORTHBOUND			SOUTHBOUND			WESTBOUND			EASTBOUND		
	LT	TH	RT	LT	TH	RT	LT	TH	RT	LT	TH	RT
EXISTING	1500	2030	450	0	2250	10	0	0	10	0	0	1710
AMBIENT												
RELATED												
PROJECT												
TOTAL	1500	2030	450	0	2250	10	0	0	10	0	0	1710
LANE	4	2	1	3	3	1	1	1	1	4	4	4
Phasing	Prot-Fix		Auto	<none>		Auto	<none>		Auto	<none>		Auto
SIGNAL	Prot-Fix		Auto	<none>		Auto	<none>		Auto	<none>		Auto

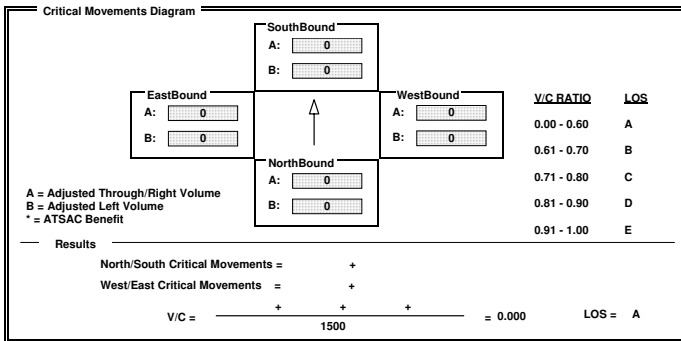

INTERSECTION DATA SUMMARY SHEET

N/S: W/E: I/S No:

AM/PM: Comments:

COUNT DATE: STUDY DATE: GROWTH FACTOR:

	NORTHBOUND			SOUTHBOUND			WESTBOUND			EASTBOUND		
	LT	TH	RT	LT	TH	RT	LT	TH	RT	LT	TH	RT
EXISTING	250	1400	160	210	1560	50	270	740	270	160	970	390
AMBIENT												
RELATED												
PROJECT												
TOTAL	250	1400	160	210	1560	50	270	740	270	160	970	390
LANE	2	2	1	2	2	1	2	2	1	2	3	1
Phasing	Prot-Fix		Auto	Prot-Fix		Auto	Prot-Fix		OLA	Prot-Fix		OLA
SIGNAL	Prot-Fix		Auto	Prot-Fix		Auto	Prot-Fix		OLA	Prot-Fix		OLA

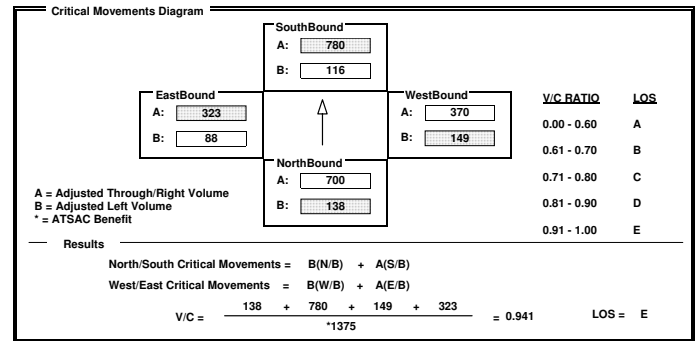

INTERSECTION DATA SUMMARY SHEET

N/S: Lincoln Blvd W/E: Washington Blvd I/S No: 110
AM/PM: PM Comments: Plus Project
COUNT DATE: STUDY DATE: GROWTH FACTOR:

Volume/Lane/Signal Configurations table with columns for Northbound, Southbound, Westbound, Eastbound and rows for Existing, Ambient, Related, Project, Total, Lane, and Signal.

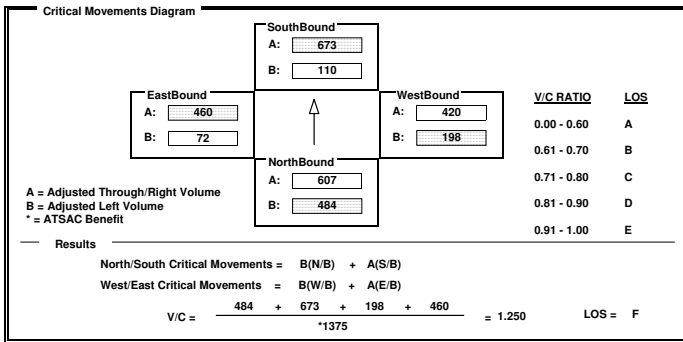

INTERSECTION DATA SUMMARY SHEET

N/S: Lincoln Blvd W/E: 83rd St I/S No: 111
AM/PM: PM Comments: Plus Project
COUNT DATE: STUDY DATE: GROWTH FACTOR:

Volume/Lane/Signal Configurations table with columns for Northbound, Southbound, Westbound, Eastbound and rows for Existing, Ambient, Related, Project, Total, Lane, and Signal.

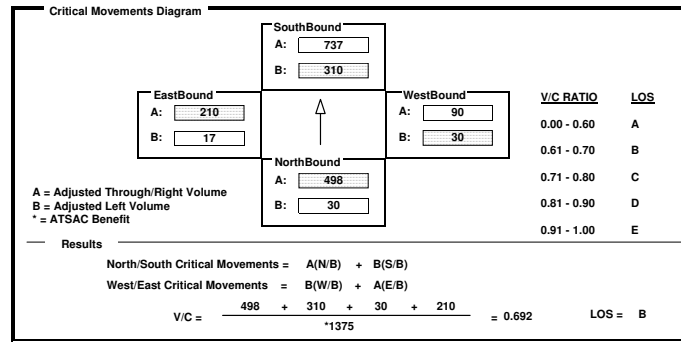

INTERSECTION DATA SUMMARY SHEET

N/S: Sepulveda Blvd W/E: Manchester Ave I/S No: 114
AM/PM: PM Comments: Plus Project
COUNT DATE: STUDY DATE: GROWTH FACTOR:

Volume/Lane/Signal Configurations table with columns for Northbound, Southbound, Westbound, Eastbound and rows for Existing, Ambient, Related, Project, Total, Lane, and Signal.

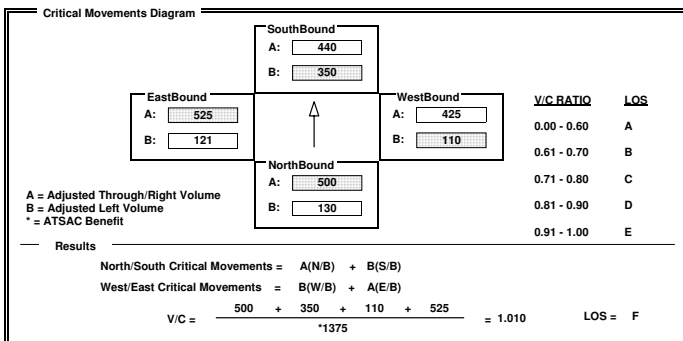

INTERSECTION DATA SUMMARY SHEET

N/S: Sepulveda Blvd W/E: Westchester Pkwy I/S No: 135
AM/PM: PM Comments: Plus Project
COUNT DATE: STUDY DATE: GROWTH FACTOR:

Volume/Lane/Signal Configurations table with columns for Northbound, Southbound, Westbound, Eastbound and rows for Existing, Ambient, Related, Project, Total, Lane, and Signal.

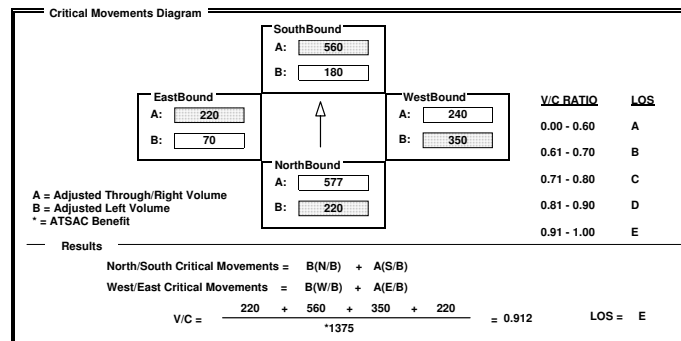

INTERSECTION DATA SUMMARY SHEET

N/S: W/E: I/S No:

AM/PM: Comments:

COUNT DATE: STUDY DATE: GROWTH FACTOR:

	NORTHBOUND			SOUTHBOUND			WESTBOUND			EASTBOUND		
	LT	TH	RT	LT	TH	RT	LT	TH	RT	LT	TH	RT
EXISTING	50	1970	40	130	2110	350	40	120	90	350	90	90
AMBIENT												
RELATED												
PROJECT												
TOTAL	50	1970	40	130	2110	350	40	120	90	350	90	90
LANE	1	3	1	1	2	1	1	1	1	2	1	1
SIGNAL	Phasing: Perm	RTOR: Auto		Phasing: Perm	RTOR: Auto		Phasing: Split	RTOR: Auto		Phasing: Split	RTOR: Auto	

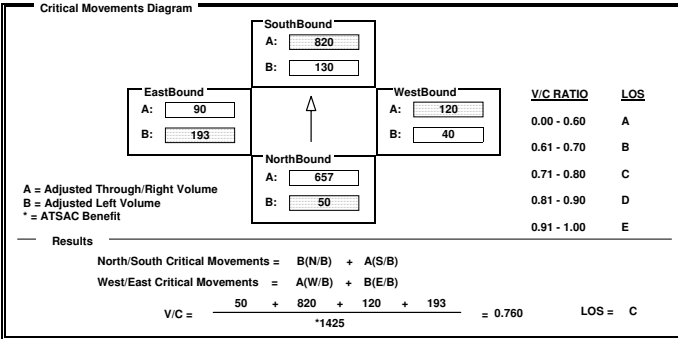

INTERSECTION DATA SUMMARY SHEET

N/S: W/E: I/S No:

AM/PM: Comments:

COUNT DATE: STUDY DATE: GROWTH FACTOR:

	NORTHBOUND			SOUTHBOUND			WESTBOUND			EASTBOUND		
	LT	TH	RT	LT	TH	RT	LT	TH	RT	LT	TH	RT
EXISTING	100	1840	20	130	1830	240	50	80	40	140	90	110
AMBIENT												
RELATED												
PROJECT												
TOTAL	100	1840	20	130	1830	240	50	80	40	140	90	110
LANE	1	2	1	1	3	1	1	1	1	1	1	1
SIGNAL	Phasing: Perm	RTOR: Auto		Phasing: Perm	RTOR: Auto		Phasing: Perm	RTOR: Auto		Phasing: Perm	RTOR: Auto	

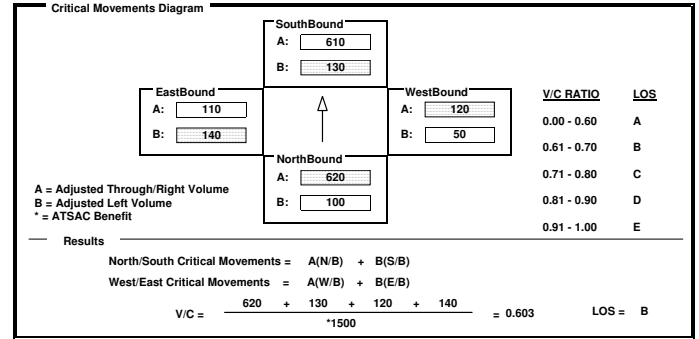

INTERSECTION DATA SUMMARY SHEET

N/S: W/E: I/S No:

AM/PM: Comments:

COUNT DATE: STUDY DATE: GROWTH FACTOR:

	NORTHBOUND			SOUTHBOUND			WESTBOUND			EASTBOUND		
	LT	TH	RT	LT	TH	RT	LT	TH	RT	LT	TH	RT
EXISTING	70	1840	20	100	1850	80	10	70	40	80	140	60
AMBIENT												
RELATED												
PROJECT												
TOTAL	70	1840	20	100	1850	80	10	70	40	80	140	60
LANE	1	2	1	1	2	1	1	1	1	1	1	1
SIGNAL	Phasing: Perm	RTOR: Auto		Phasing: Perm	RTOR: Auto		Phasing: Perm	RTOR: Auto		Phasing: Perm	RTOR: Auto	

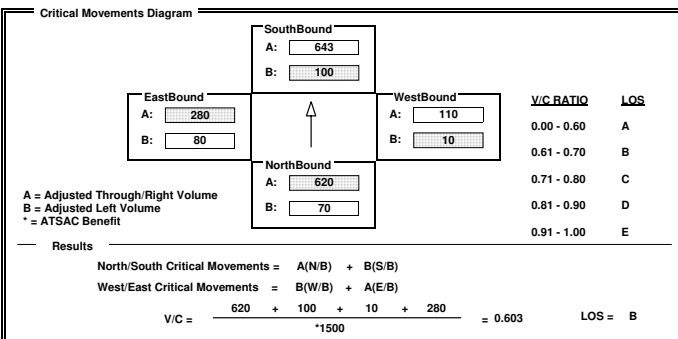

INTERSECTION DATA SUMMARY SHEET

N/S: W/E: I/S No:

AM/PM: Comments:

COUNT DATE: STUDY DATE: GROWTH FACTOR:

	NORTHBOUND			SOUTHBOUND			WESTBOUND			EASTBOUND		
	LT	TH	RT	LT	TH	RT	LT	TH	RT	LT	TH	RT
EXISTING	0	2320	0	0	0	0	0	0	1930	0	0	0
AMBIENT												
RELATED												
PROJECT												
TOTAL	0	2320	0	0	0	0	0	0	1930	0	0	0
LANE	3			0					3			0
SIGNAL	Phasing: Split	RTOR: <none>		Phasing: <none>	RTOR: <none>		Phasing: <none>	RTOR: <none>		Phasing: Split	RTOR: <none>	

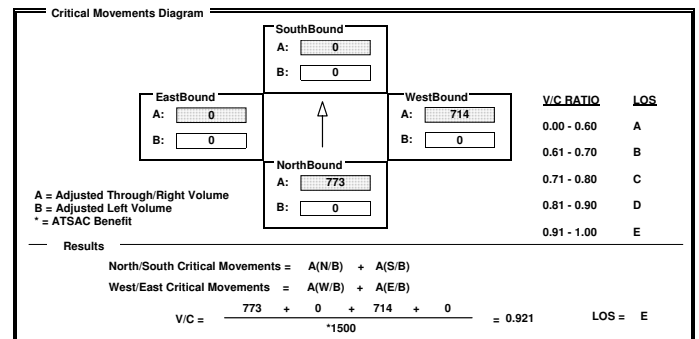

INTERSECTION DATA SUMMARY SHEET

N/S: Airport Blvd W/E: 96th St I/S No: 141
AM/PM: PM Comments: Plus Project
COUNT DATE: STUDY DATE: GROWTH FACTOR:

Volume/Lane/Signal Configurations table with columns for Northbound, Southbound, Westbound, Eastbound and rows for Existing, Ambient, Related, Project, Total, Lane, and Signal.

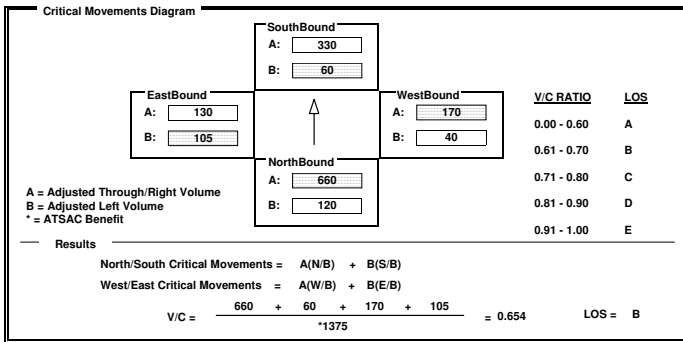

INTERSECTION DATA SUMMARY SHEET

N/S: Airport Blvd W/E: 98 St I/S No: 144
AM/PM: PM Comments: Plus Project
COUNT DATE: STUDY DATE: GROWTH FACTOR:

Volume/Lane/Signal Configurations table with columns for Northbound, Southbound, Westbound, Eastbound and rows for Existing, Ambient, Related, Project, Total, Lane, and Signal.

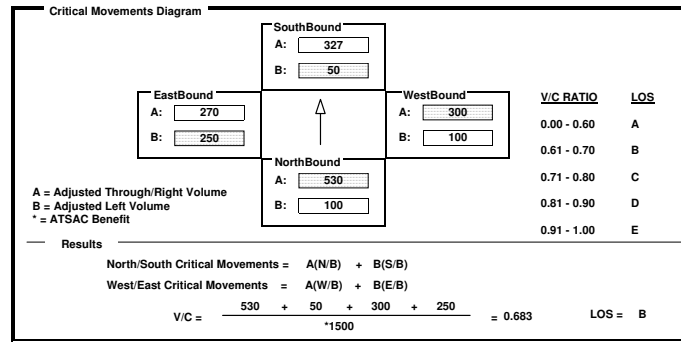

INTERSECTION DATA SUMMARY SHEET

N/S: Sepulveda Eastway W/E: Westchester Pkwy I/S No: 146
AM/PM: PM Comments: Plus Project
COUNT DATE: STUDY DATE: GROWTH FACTOR:

Volume/Lane/Signal Configurations table with columns for Northbound, Southbound, Westbound, Eastbound and rows for Existing, Ambient, Related, Project, Total, Lane, and Signal.

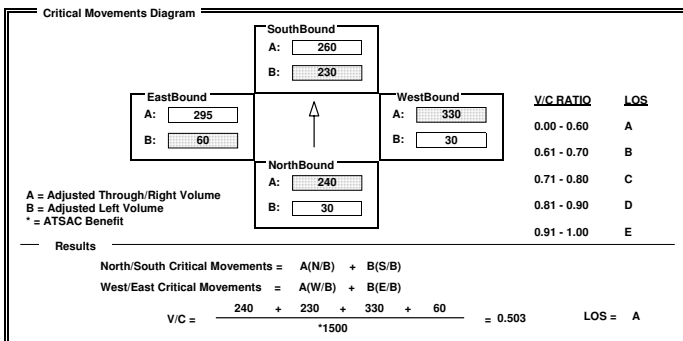

INTERSECTION DATA SUMMARY SHEET

N/S: La Cienega Blvd W/E: I-405 SB Ramps N/O Century I/S No: 96
AM/PM: PM Comments: Cumulative (2013) Plus Project
COUNT DATE: STUDY DATE: GROWTH FACTOR:

Volume/Lane/Signal Configurations table with columns for Northbound, Southbound, Westbound, Eastbound and rows for Existing, Ambient, Related, Project, Total, Lane, and Signal.

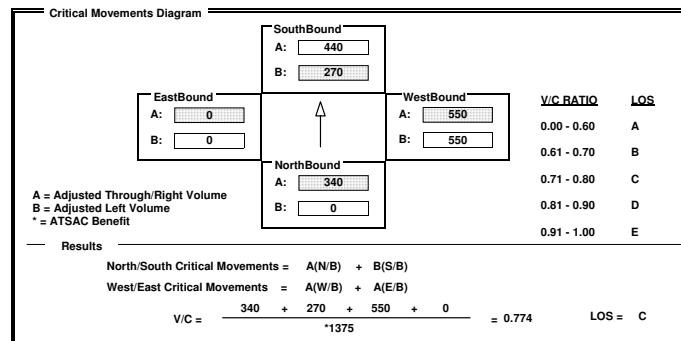

INTERSECTION DATA SUMMARY SHEET

N/S: W/E: I/S No:

AM/PM: PM Comments:

COUNT DATE: STUDY DATE: GROWTH FACTOR:

Volume/Lane/Signal Configurations

	NORTHBOUND			SOUTHBOUND			WESTBOUND			EASTBOUND		
	LT	TH	RT	LT	TH	RT	LT	TH	RT	LT	TH	RT
EXISTING	0	780	40	710	1000	0	0	0	490	0	0	0
AMBIENT												
RELATED												
PROJECT												
TOTAL	0	780	40	710	1000	0	0	0	490	0	0	0
LANE	1 1 1			2 2 1			2			1 1 1		
SIGNAL	Phasing RTOR		Phasing RTOR		Phasing RTOR		Phasing RTOR		Phasing RTOR		Phasing RTOR	
	Perm Auto		Prot-Fix Auto		Split OLA		Split Auto					

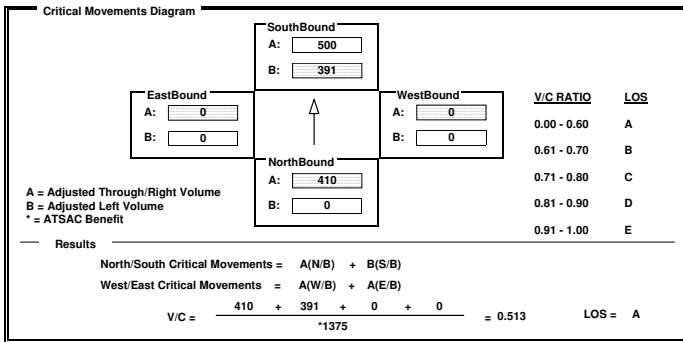

INTERSECTION DATA SUMMARY SHEET

N/S: W/E: I/S No:

AM/PM: PM Comments:

COUNT DATE: STUDY DATE: GROWTH FACTOR:

Volume/Lane/Signal Configurations

	NORTHBOUND			SOUTHBOUND			WESTBOUND			EASTBOUND		
	LT	TH	RT	LT	TH	RT	LT	TH	RT	LT	TH	RT
EXISTING	160	2460	180	190	2430	20	130	720	100	40	1000	260
AMBIENT												
RELATED												
PROJECT												
TOTAL	160	2460	180	190	2430	20	130	720	100	40	1000	260
LANE	2 2 1			1 2 1			1 2 1			1 2 1		
SIGNAL	Phasing RTOR		Phasing RTOR		Phasing RTOR		Phasing RTOR		Phasing RTOR		Phasing RTOR	
	Prot-Fix Auto		Prot-Fix Auto		Prot-Fix Auto		Prot-Fix Auto		Prot-Fix Auto		Perm Auto	

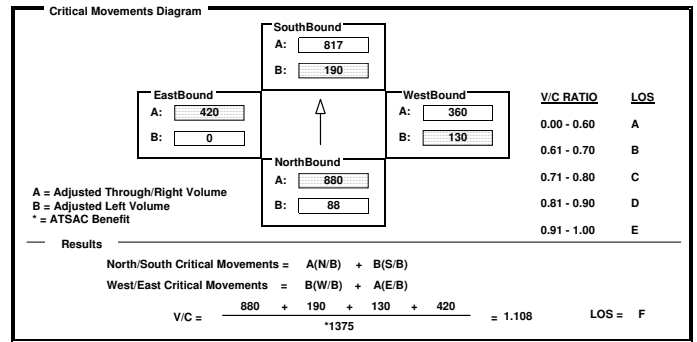

INTERSECTION DATA SUMMARY SHEET

N/S: W/E: I/S No:

AM/PM: PM Comments:

COUNT DATE: STUDY DATE: GROWTH FACTOR:

Volume/Lane/Signal Configurations

	NORTHBOUND			SOUTHBOUND			WESTBOUND			EASTBOUND		
	LT	TH	RT	LT	TH	RT	LT	TH	RT	LT	TH	RT
EXISTING	70	1460	210	110	1340	180	390	1330	110	140	1100	160
AMBIENT												
RELATED												
PROJECT												
TOTAL	70	1460	210	110	1340	180	390	1330	110	140	1100	160
LANE	1 2 1			1 2 1			1 2 1			1 2 1		
SIGNAL	Phasing RTOR		Phasing RTOR		Phasing RTOR		Phasing RTOR		Phasing RTOR		Phasing RTOR	
	Perm Auto		Prot-Fix Auto		Prot-Fix Auto		Prot-Fix Auto		Prot-Fix Auto		Prot-Fix Auto	

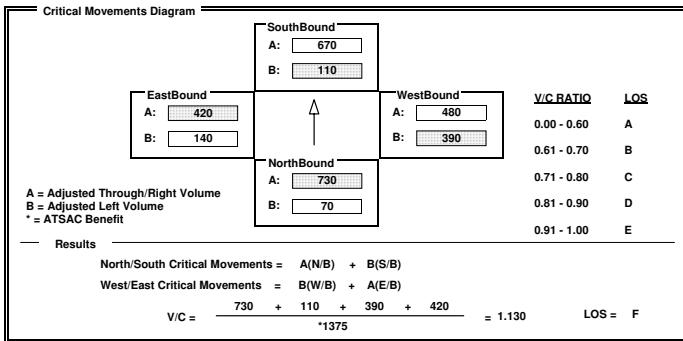

INTERSECTION DATA SUMMARY SHEET

N/S: W/E: I/S No:

AM/PM: PM Comments:

COUNT DATE: STUDY DATE: GROWTH FACTOR:

Volume/Lane/Signal Configurations

	NORTHBOUND			SOUTHBOUND			WESTBOUND			EASTBOUND		
	LT	TH	RT	LT	TH	RT	LT	TH	RT	LT	TH	RT
EXISTING	90	680	40	290	880	100	40	800	140	120	1190	110
AMBIENT												
RELATED												
PROJECT												
TOTAL	90	680	40	290	880	100	40	800	140	120	1190	110
LANE	1 1 1			1 2 1			1 2 1			1 2 1		
SIGNAL	Phasing RTOR		Phasing RTOR		Phasing RTOR		Phasing RTOR		Phasing RTOR		Phasing RTOR	
	Prot-Fix Auto		Prot-Fix Auto		Prot-Fix Auto		Prot-Fix Auto		Prot-Fix Auto		Prot-Fix Auto	

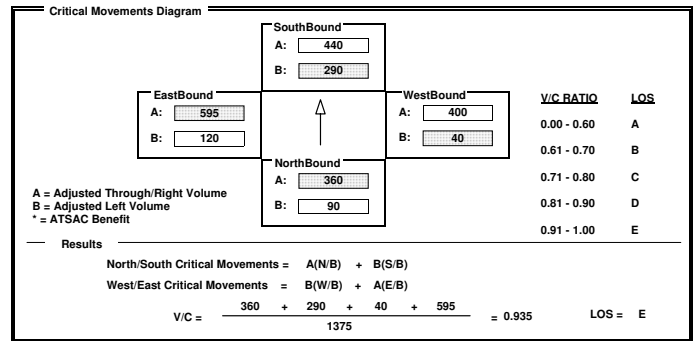

INTERSECTION DATA SUMMARY SHEET

N/S: La Cienega Blvd W/E: Stocker Ave I/S No: 93
AM/PM: PM Comments: Cumulative (2013) With Project
COUNT DATE: STUDY DATE: GROWTH FACTOR:

Volume/Lane/Signal Configurations table with columns for Northbound, Southbound, Westbound, Eastbound and rows for Existing, Ambient, Related, Project, Total, Lane, Phasing, RTOR, Signal.

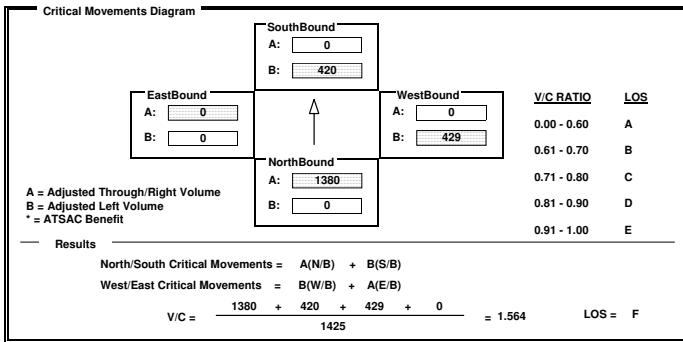

INTERSECTION DATA SUMMARY SHEET

N/S: Overland Ave W/E: Venice Blvd I/S No: 121
AM/PM: PM Comments: Cumulative (2013) With Project
COUNT DATE: STUDY DATE: GROWTH FACTOR:

Volume/Lane/Signal Configurations table with columns for Northbound, Southbound, Westbound, Eastbound and rows for Existing, Ambient, Related, Project, Total, Lane, Phasing, RTOR, Signal.

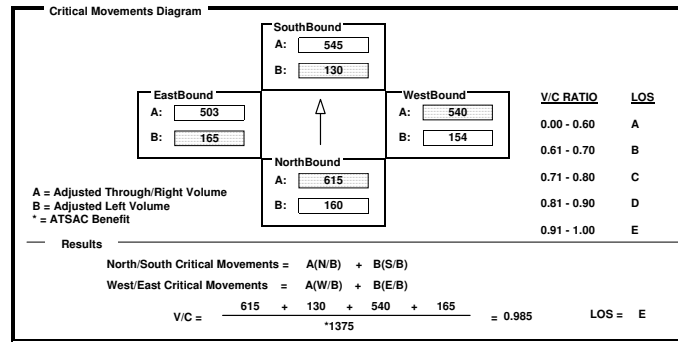

INTERSECTION DATA SUMMARY SHEET

N/S: Lincoln Blvd W/E: Rose Ave I/S No: 160
AM/PM: PM Comments: Cumulative (2013) With Project
COUNT DATE: STUDY DATE: GROWTH FACTOR:

Volume/Lane/Signal Configurations table with columns for Northbound, Southbound, Westbound, Eastbound and rows for Existing, Ambient, Related, Project, Total, Lane, Phasing, RTOR, Signal.

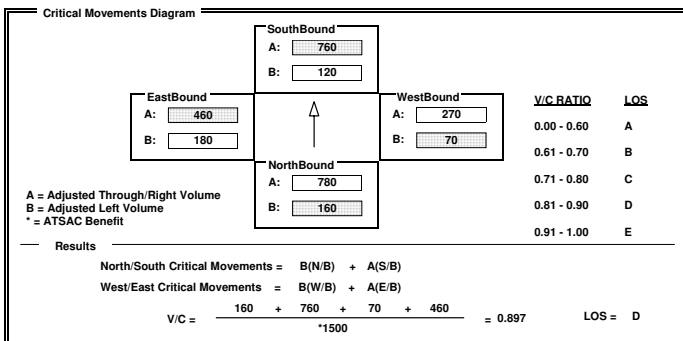

INTERSECTION DATA SUMMARY SHEET

N/S: Western Ave W/E: Century Blvd I/S No: 161
AM/PM: PM Comments: Cumulative (2013) With Project
COUNT DATE: STUDY DATE: GROWTH FACTOR:

Volume/Lane/Signal Configurations table with columns for Northbound, Southbound, Westbound, Eastbound and rows for Existing, Ambient, Related, Project, Total, Lane, Phasing, RTOR, Signal.

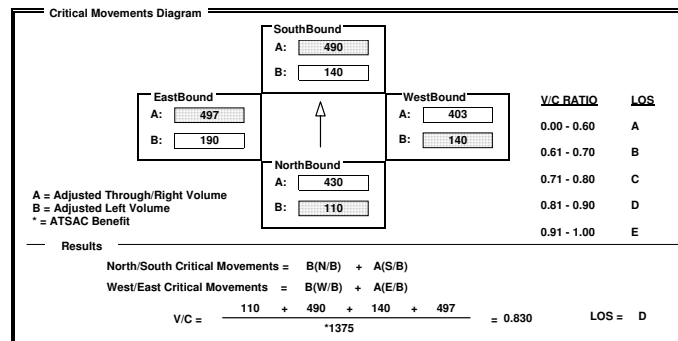

INTERSECTION DATA SUMMARY SHEET

N/S: La Cienega Blvd W/E: Jefferson Blvd IS No: 200
AM/PM: PM Comments: Cumulative (2013) With Project
COUNT DATE: STUDY DATE: GROWTH FACTOR:

Volume/Lane/Signal Configurations table with columns for Northbound, Southbound, Westbound, Eastbound and rows for Existing, Ambient, Related, Project, Total, Lane, and Signal.

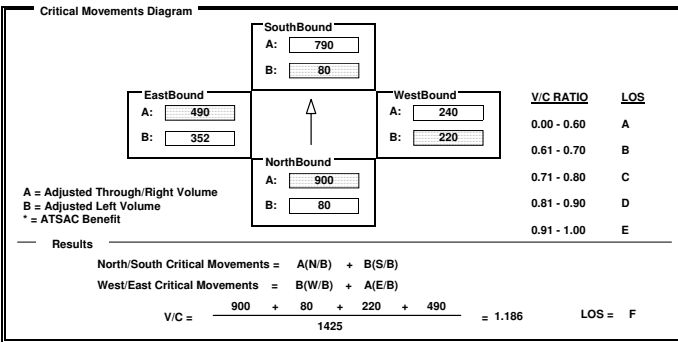

Project Title: Bradley West Project Intersection: 12 - Arbor Vitae St and La Brea Ave Description: Future (2013) With Project Conditions. Includes AM and PM Peak Hour analysis tables.

* - Denotes critical movement

Project Title: Bradley West Project Intersection: 13 - Arbor Vitae St and La Cienega Blvd Description: Future (2013) With Project Conditions. Includes AM, MD, and PM Peak Hour analysis tables.

* - Denotes critical movement

Project Title: Bradley West Project Intersection: 17 - Aviation Bl / Florence Ave and Manchester Bl Description: Future (2013) With Project Conditions. Includes AM, MD, and PM Peak Hour analysis tables.

* - Denotes critical movement

Project Title:		Bradley West Project				
Intersection:		28 - Centinela Ave and Sepulveda Blvd				
Description:		Future (2013) With Project Conditions				
Date/Time: AM PEAK HOUR						
Thru Lane:	1600 vph	N-S Split Phase :	N			
Left Lane:	1600 vph	E-W Split Phase :	N			
Double Lt Penalty:	20 %	Lost Time (% of cycle):	10			
ITS:	10 %	V/C Round Off (decs.):	3			
OLA Movements :	EBR					
FF Movements:						
APPROACH	MVMT	LANES	VOLUME	CAPACITY	V/C	ICU ANALYSIS
Southbound	RT	1.00	180	1,600	0.078	N-S(1): 0.317 N-S(2): 0.440 * E-W(1): 0.171 E-W(2): 0.363 *
	TH	3.00	610	4,800	0.127 *	
	LT	2.00	70	2,560	0.027	
Westbound	RT	0.00	220	0	0.000	V/C: 0.803 Lost Time: 0.100 ITS: -0.100
	TH	2.00	720	3,200	0.294 *	
	LT	2.00	320	2,560	0.125	
Northbound	RT	1.00	230	1,600	0.081 *	ICU: 0.803 LOS: D
	TH	3.00	1,390	4,800	0.290	
	LT	2.00	800	2,560	0.313 *	
Eastbound	RT	2.00	440	3,200	0.050	
	TH	3.00	220	4,800	0.046 *	
	LT	1.00	110	1,600	0.069 *	

* - Denotes critical movement

Project Title:		Bradley West Project				
Intersection:		34 - Century Blvd and Hawthorne Blvd / La Brea Ave				
Description:		Future (2013) With Project Conditions				
Date/Time: AM PEAK HOUR						
Thru Lane:	1600 vph	N-S Split Phase :	N			
Left Lane:	1600 vph	E-W Split Phase :	N			
Double Lt Penalty:	20 %	Lost Time (% of cycle):	10			
ITS:	0 %	V/C Round Off (decs.):	3			
OLA Movements :						
FF Movements:						
APPROACH	MVMT	LANES	VOLUME	CAPACITY	V/C	ICU ANALYSIS
Southbound	RT	1.00	160	1,600	0.069	N-S(1): 0.213 N-S(2): 0.260 * E-W(1): 0.231 E-W(2): 0.321 *
	TH	3.00	530	4,800	0.110 *	
	LT	1.00	80	1,600	0.050	
Westbound	RT	0.00	110	0	0.000	V/C: 0.581 Lost Time: 0.100 ITS: 0.000
	TH	3.00	1,130	4,800	0.258 *	
	LT	1.00	80	1,600	0.050	
Northbound	RT	1.00	90	1,600	0.031	ICU: 0.681 LOS: B
	TH	3.00	780	4,800	0.163	
	LT	1.00	240	1,600	0.150 *	
Eastbound	RT	0.00	290	1,600	0.181	
	TH	3.00	540	3,200	0.169	
	LT	1.00	100	1,600	0.063 *	

* - Denotes critical movement

Project Title:		Bradley West Project				
Intersection:		35 - Century Blvd and Inglewood Ave				
Description:		Future (2013) With Project Conditions				
Date/Time: AM PEAK HOUR						
Thru Lane:	1600 vph	N-S Split Phase :	N			
Left Lane:	1600 vph	E-W Split Phase :	N			
Double Lt Penalty:	20 %	Lost Time (% of cycle):	10			
ITS:	0 %	V/C Round Off (decs.):	3			
OLA Movements :						
FF Movements:						
APPROACH	MVMT	LANES	VOLUME	CAPACITY	V/C	ICU ANALYSIS
Southbound	RT	1.00	100	1,600	0.034	N-S(1): 0.187 N-S(2): 0.219 * E-W(1): 0.235 E-W(2): 0.385 *
	TH	1.00	190	1,600	0.119 *	
	LT	1.00	50	1,600	0.031	
Westbound	RT	0.00	90	0	0.000	V/C: 0.604 Lost Time: 0.100 ITS: 0.000
	TH	3.00	1,490	4,800	0.329 *	
	LT	1.00	90	1,600	0.056 *	
Northbound	RT	1.00	60	1,600	0.013	ICU: 0.704 LOS: C
	TH	1.00	250	1,600	0.156	
	LT	1.00	160	1,600	0.100 *	
Eastbound	RT	0.00	90	0	0.000	
	TH	3.00	810	4,800	0.185	
	LT	1.00	90	1,600	0.056 *	

* - Denotes critical movement

Project Title:		Bradley West Project				
Intersection:		37 - Century Blvd and Prairie Ave				
Description:		Future (2013) With Project Conditions				
Date/Time: AM PEAK HOUR						
Thru Lane:	1600 vph	N-S Split Phase :	N			
Left Lane:	1600 vph	E-W Split Phase :	N			
Double Lt Penalty:	20 %	Lost Time (% of cycle):	10			
ITS:	0 %	V/C Round Off (decs.):	3			
OLA Movements :						
FF Movements:						
APPROACH	MVMT	LANES	VOLUME	CAPACITY	V/C	ICU ANALYSIS
Southbound	RT	0.00	90	0	0.000	N-S(1): 0.327 * N-S(2): 0.271 E-W(1): 0.156 E-W(2): 0.321 *
	TH	3.00	700	4,800	0.185	
	LT	1.00	210	1,600	0.131 *	
Westbound	RT	0.00	290	0	0.000	V/C: 0.648 Lost Time: 0.100 ITS: 0.000
	TH	3.00	980	4,800	0.285 *	
	LT	1.00	50	1,600	0.031	
Northbound	RT	0.00	80	0	0.000	ICU: 0.748 LOS: C
	TH	3.00	860	4,800	0.196 *	
	LT	1.00	170	1,600	0.106	
Eastbound	RT	0.00	110	0	0.000	
	TH	3.00	490	4,800	0.125	
	LT	1.00	90	1,600	0.056 *	

* - Denotes critical movement

Project Title: Bradley West Project
Intersection: 162 - Manhattan Beach Blvd and Sepulveda Blvd
Description: Future (2013) With Project Conditions

Date/Time: AM PEAK HOUR

Thru Lane: 1600 vph
 Left Lane: 1600 vph
 Double Lt Penalty: 20 %
 ITS: 0 %
 OLA Movements: WBR
 FF Movements:

N-S Split Phase: N
 E-W Split Phase: N
 Lost Time % of cycle: 10
 V/C Round Off (decs): 3

APPROACH	MVMT	LANES	VOLUME	CAPACITY	V/C	ICU ANALYSIS
Southbound	RT	0.00	140	0	0.000	N-S(1): 0.725 * N-S(2): 0.284 E-W(1): 0.266 E-W(2): 0.307 * V/C: 1.032 Lost Time: 0.100 ITS: 0.000 ICU: 1.132 LOS: F
	TH	3.00	890	4,800	0.215	
	LT	2.00	90	2,560	0.035 *	
Westbound	RT	1.00	220	1,600	0.102	
	TH	2.00	620	3,200	0.194 *	
	LT	1.00	140	1,600	0.088 *	
Northbound	RT	0.00	110	0	0.000	
	TH	3.00	3,200	4,800	0.669 *	
	LT	1.00	110	1,600	0.069	
Eastbound	RT	1.00	140	1,600	0.053	
	TH	2.00	570	3,200	0.178	
	LT	1.00	180	1,600	0.113 *	

Date/Time: MD PEAK HOUR

APPROACH	MVMT	LANES	VOLUME	CAPACITY	V/C	ICU ANALYSIS
Southbound	RT	0.00	160	0	0.000	N-S(1): 0.401 * N-S(2): 0.401 * E-W(1): 0.316 E-W(2): 0.325 * V/C: 0.726 Lost Time: 0.100 ITS: 0.000 ICU: 0.826 LOS: D
	TH	3.00	1,340	4,800	0.313 *	
	LT	2.00	140	2,560	0.055	
Westbound	RT	1.00	170	1,600	0.052	
	TH	2.00	490	3,200	0.150 *	
	LT	1.00	280	1,600	0.175	
Northbound	RT	0.00	170	0	0.000	
	TH	3.00	1,490	4,800	0.346	
	LT	1.00	140	1,600	0.088 *	
Eastbound	RT	1.00	180	1,600	0.069	
	TH	2.00	450	3,200	0.141	
	LT	1.00	280	1,600	0.175 *	

Date/Time: PM PEAK HOUR

APPROACH	MVMT	LANES	VOLUME	CAPACITY	V/C	ICU ANALYSIS
Southbound	RT	0.00	130	0	0.000	N-S(1): 0.384 N-S(2): 0.684 * E-W(1): 0.376 * E-W(2): 0.331 V/C: 1.060 Lost Time: 0.100 ITS: 0.000 ICU: 1.160 LOS: F
	TH	3.00	2,580	4,800	0.565 *	
	LT	2.00	200	2,560	0.078	
Westbound	RT	1.00	150	1,600	0.016	
	TH	2.00	660	3,200	0.206	
	LT	1.00	300	1,600	0.188 *	
Northbound	RT	0.00	150	0	0.000	
	TH	3.00	1,320	4,800	0.306	
	LT	1.00	190	1,600	0.119 *	
Eastbound	RT	1.00	160	1,600	0.041	
	TH	2.00	600	3,200	0.188 *	
	LT	1.00	200	1,600	0.125	

* - Denotes critical movement

INTERSECTION DATA SUMMARY SHEET

N/S: Airport Blvd W/E: Westchester Blvd I/S No: 6
 AM/PM: AM Comments: Plus Project
 COUNT DATE: STUDY DATE: GROWTH FACTOR:

Volume/Lane/Signal Configurations

	NORTHBOUND			SOUTHBOUND			WESTBOUND			EASTBOUND		
	LT	TH	RT	LT	TH	RT	LT	TH	RT	LT	TH	RT
EXISTING	380	630	230	100	850	190	300	670	270	110	300	130
AMBIENT												
RELATED												
PROJECT												
TOTAL	380	630	230	100	850	190	300	670	270	110	300	130

LANE: 2 2 1 1 3 1 2 1 1 1 2 1 1

SIGNAL: Prot-Fix Auto Prot-Fix Auto Prot-Fix Auto Prot-Fix Auto

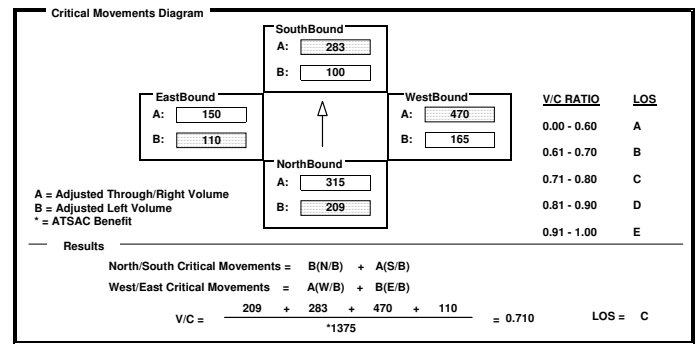

INTERSECTION DATA SUMMARY SHEET

N/S: Airport Blvd W/E: Century Blvd I/S No: 7
 AM/PM: AM Comments: Plus Project
 COUNT DATE: STUDY DATE: GROWTH FACTOR:

Volume/Lane/Signal Configurations

	NORTHBOUND			SOUTHBOUND			WESTBOUND			EASTBOUND		
	LT	TH	RT	LT	TH	RT	LT	TH	RT	LT	TH	RT
EXISTING	30	50	50	320	30	430	80	2770	470	570	1600	30
AMBIENT												
RELATED												
PROJECT												
TOTAL	30	50	50	320	30	430	80	2770	470	570	1600	30

LANE: 1 2 1 2 1 4 1 2 4 1

SIGNAL: Split Auto Split Auto Prot-Fix OLA Prot-Fix Auto

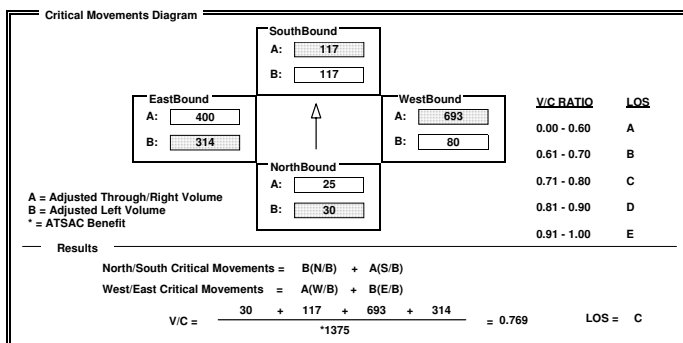

INTERSECTION DATA SUMMARY SHEET

N/S: Airport Blvd W/E: Manchester Ave I/S No: 9
 AM/PM: AM Comments: Plus Project
 COUNT DATE: STUDY DATE: GROWTH FACTOR:

Volume/Lane/Signal Configurations

	NORTHBOUND			SOUTHBOUND			WESTBOUND			EASTBOUND		
	LT	TH	RT	LT	TH	RT	LT	TH	RT	LT	TH	RT
EXISTING	120	740	100	90	740	30	150	1280	210	30	610	120
AMBIENT												
RELATED												
PROJECT												
TOTAL	120	740	100	90	740	30	150	1280	210	30	610	120

LANE: 1 2 1 1 1 1 2 1 1 2 1 1

SIGNAL: Prot-Fix Auto Prot-Fix Auto Prot-Fix Auto Prot-Fix Auto

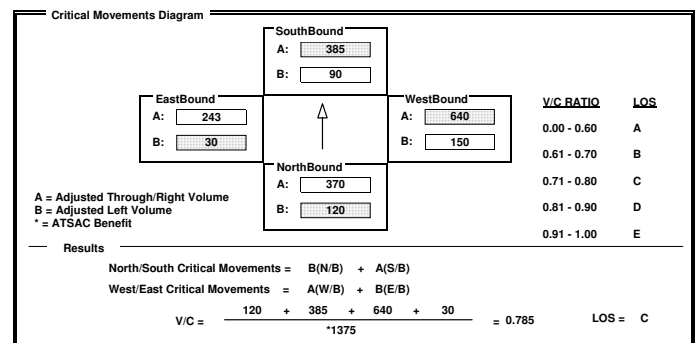

INTERSECTION DATA SUMMARY SHEET

N/S: Aviation Blvd W/E: Arbor Vitae St I/S No: 10
AM/PM: AM Comments: Plus Project
COUNT DATE: STUDY DATE: GROWTH FACTOR:

Volume/Lane/Signal Configurations table with columns for Northbound, Southbound, Westbound, Eastbound and rows for Existing, Ambient, Related, Project, Total, Lane, Phasing, RTOR, Signal.

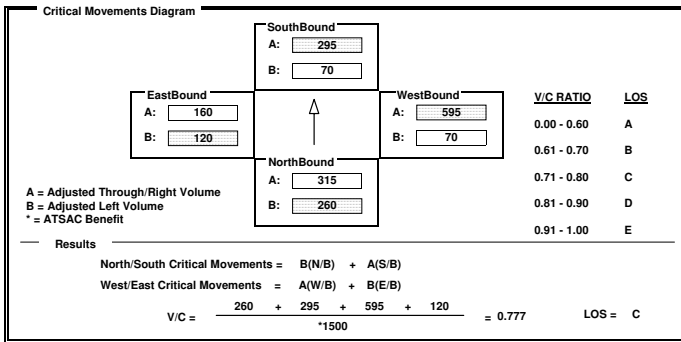

INTERSECTION DATA SUMMARY SHEET

N/S: Aviation Blvd W/E: Century Blvd I/S No: 14
AM/PM: AM Comments: Plus Project
COUNT DATE: STUDY DATE: GROWTH FACTOR:

Volume/Lane/Signal Configurations table with columns for Northbound, Southbound, Westbound, Eastbound and rows for Existing, Ambient, Related, Project, Total, Lane, Phasing, RTOR, Signal.

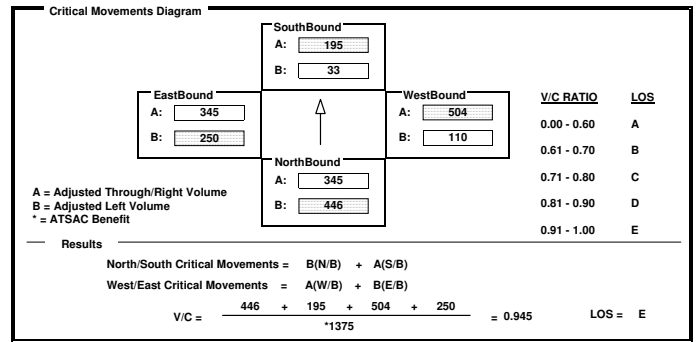

INTERSECTION DATA SUMMARY SHEET

N/S: Aviation Blvd W/E: Imperial Hwy I/S No: 16
AM/PM: AM Comments: Plus Project
COUNT DATE: STUDY DATE: GROWTH FACTOR:

Volume/Lane/Signal Configurations table with columns for Northbound, Southbound, Westbound, Eastbound and rows for Existing, Ambient, Related, Project, Total, Lane, Phasing, RTOR, Signal.

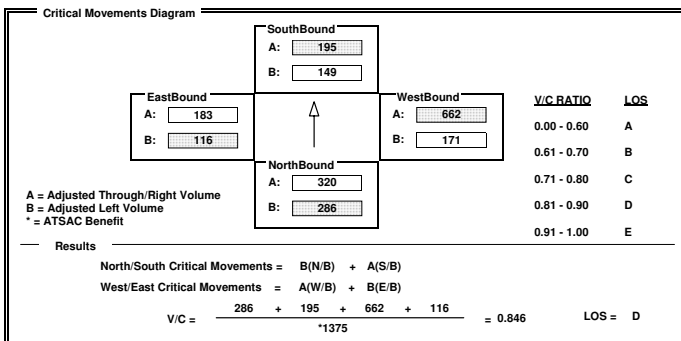

INTERSECTION DATA SUMMARY SHEET

N/S: La Cienega Blvd W/E: Century Blvd I/S No: 36
AM/PM: AM Comments: Plus Project
COUNT DATE: STUDY DATE: GROWTH FACTOR:

Volume/Lane/Signal Configurations table with columns for Northbound, Southbound, Westbound, Eastbound and rows for Existing, Ambient, Related, Project, Total, Lane, Phasing, RTOR, Signal.

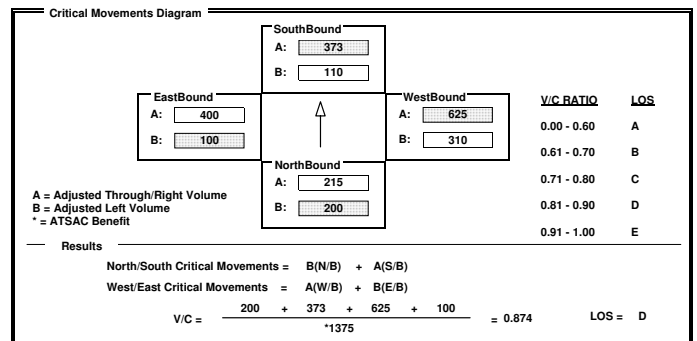

INTERSECTION DATA SUMMARY SHEET

N/S: W/E: I/S No:

AM/PM: Comments:

COUNT DATE: STUDY DATE: GROWTH FACTOR:

	NORTHBOUND			SOUTHBOUND			WESTBOUND			EASTBOUND		
	LT	TH	RT	LT	TH	RT	LT	TH	RT	LT	TH	RT
EXISTING	140	1760	720	330	2150	400	200	330	380	230	290	220
AMBIENT												
RELATED												
PROJECT												
TOTAL	140	1760	720	330	2150	400	200	330	380	230	290	220
LANE	1	3	2	2	3	1	2	2	2	2	3	1
SIGNAL	Prot-Fix	Auto	Prot-Fix	Auto	Prot-Fix	Auto	Prot-Fix	OLA	Prot-Fix	Auto	Prot-Fix	Auto

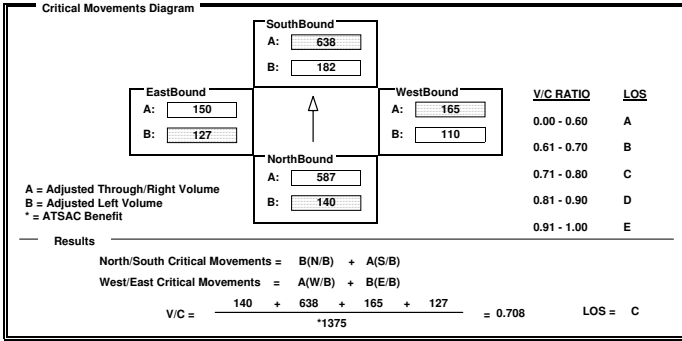

INTERSECTION DATA SUMMARY SHEET

N/S: W/E: I/S No:

AM/PM: Comments:

COUNT DATE: STUDY DATE: GROWTH FACTOR:

	NORTHBOUND			SOUTHBOUND			WESTBOUND			EASTBOUND		
	LT	TH	RT	LT	TH	RT	LT	TH	RT	LT	TH	RT
EXISTING	0	2670	120	0	2340	1150	0	0	0	780	190	20
AMBIENT												
RELATED												
PROJECT												
TOTAL	0	2670	120	0	2340	1150	0	0	0	780	190	20
LANE		2	1		3	2				3		1
SIGNAL	Perm	Auto	Perm	OLA	<none>	<none>	Split	Auto	Perm	Auto	Perm	Auto

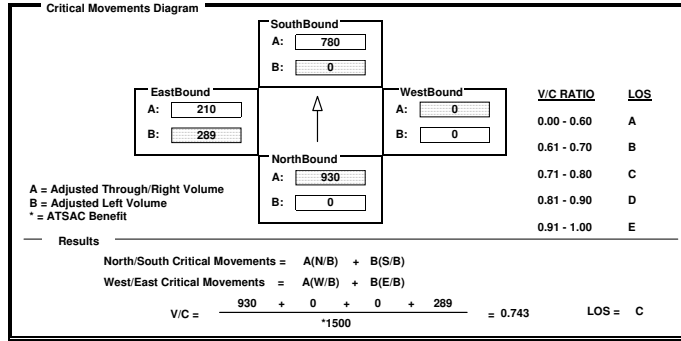

INTERSECTION DATA SUMMARY SHEET

N/S: W/E: I/S No:

AM/PM: Comments:

COUNT DATE: STUDY DATE: GROWTH FACTOR:

	NORTHBOUND			SOUTHBOUND			WESTBOUND			EASTBOUND		
	LT	TH	RT	LT	TH	RT	LT	TH	RT	LT	TH	RT
EXISTING	0	1000	120	160	460	0	990	0	90	0	0	0
AMBIENT												
RELATED												
PROJECT												
TOTAL	0	1000	120	160	460	0	990	0	90	0	0	0
LANE		1	1	2	2		1		1			
SIGNAL	Perm	OLA	Prot-Fix	Auto	Split	Auto	Split	Auto	Split	Auto	Split	Auto

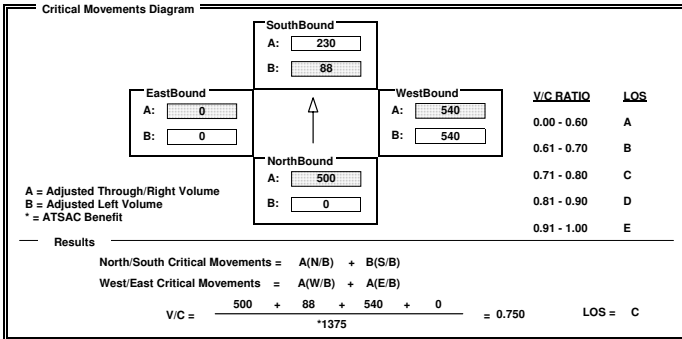

INTERSECTION DATA SUMMARY SHEET

N/S: W/E: I/S No:

AM/PM: Comments:

COUNT DATE: STUDY DATE: GROWTH FACTOR:

	NORTHBOUND			SOUTHBOUND			WESTBOUND			EASTBOUND		
	LT	TH	RT	LT	TH	RT	LT	TH	RT	LT	TH	RT
EXISTING	110	1590	170	70	1290	60	530	200	40	50	320	80
AMBIENT												
RELATED												
PROJECT												
TOTAL	110	1590	170	70	1290	60	530	200	40	50	320	80
LANE	1	3	1	1	3	1	2	1	1	1	2	1
SIGNAL	Prot-Fix	OLA	Prot-Fix	OLA	Perm	Auto	Prot-Fix	OLA	Prot-Fix	OLA	Prot-Fix	OLA

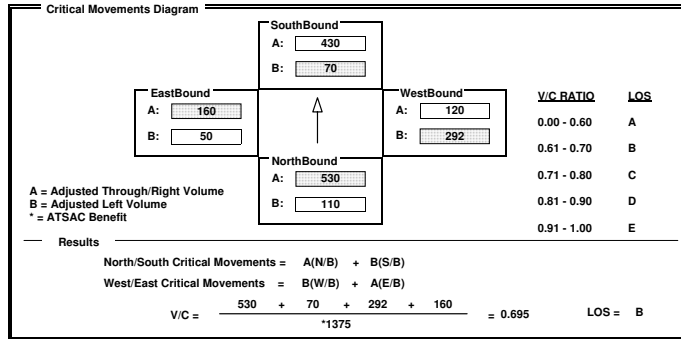

INTERSECTION DATA SUMMARY SHEET

N/S: W/E: I/S No:
 AM/PM: Comments:
 COUNT DATE: STUDY DATE: GROWTH FACTOR:

	NORTHBOUND			SOUTHBOUND			WESTBOUND			EASTBOUND		
	LT	TH	RT	LT	TH	RT	LT	TH	RT	LT	TH	RT
EXISTING	1440	2040	410	0	1710	10	0	0	10	0	0	1280
AMBIENT												
RELATED												
PROJECT												
TOTAL	1440	2040	410	0	1710	10	0	0	10	0	0	1280
LANE	4	2	1		3	1			1			4
Phasing	Prot-Fix		Auto	<none>		Auto	<none>		Auto	<none>		Auto
RTOR	Auto			<none>			<none>			<none>		Auto

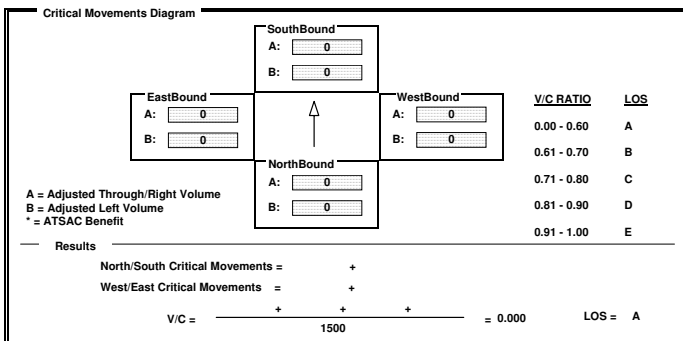

INTERSECTION DATA SUMMARY SHEET

N/S: W/E: I/S No:
 AM/PM: Comments:
 COUNT DATE: STUDY DATE: GROWTH FACTOR:

	NORTHBOUND			SOUTHBOUND			WESTBOUND			EASTBOUND		
	LT	TH	RT	LT	TH	RT	LT	TH	RT	LT	TH	RT
EXISTING	230	1710	170	200	1300	40	280	570	280	120	810	270
AMBIENT												
RELATED												
PROJECT												
TOTAL	230	1710	170	200	1300	40	280	570	280	120	810	270
LANE	2	3	1	2	3	1	2	2	1	2	3	1
Phasing	Prot-Fix		Auto	Prot-Fix		Auto	Prot-Fix		OLA	Prot-Fix		OLA
RTOR	Auto			Auto			Auto			Auto		

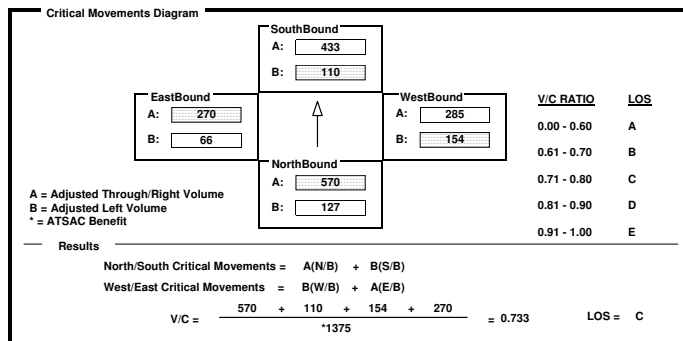

INTERSECTION DATA SUMMARY SHEET

N/S: W/E: I/S No:
 AM/PM: Comments:
 COUNT DATE: STUDY DATE: GROWTH FACTOR:

	NORTHBOUND			SOUTHBOUND			WESTBOUND			EASTBOUND		
	LT	TH	RT	LT	TH	RT	LT	TH	RT	LT	TH	RT
EXISTING	390	1790	270	230	1580	180	160	690	230	140	720	510
AMBIENT												
RELATED												
PROJECT												
TOTAL	390	1790	270	230	1580	180	160	690	230	140	720	510
LANE	2	3	1	2	3	1	2	2	1	2	2	1
Phasing	Prot-Fix		Auto	Prot-Fix		Auto	Prot-Fix		OLA	Prot-Fix		OLA
RTOR	Auto			Auto			Auto			Auto		

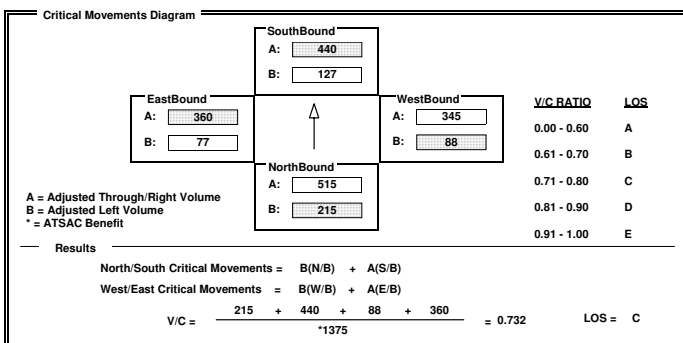

INTERSECTION DATA SUMMARY SHEET

N/S: W/E: I/S No:
 AM/PM: Comments:
 COUNT DATE: STUDY DATE: GROWTH FACTOR:

	NORTHBOUND			SOUTHBOUND			WESTBOUND			EASTBOUND		
	LT	TH	RT	LT	TH	RT	LT	TH	RT	LT	TH	RT
EXISTING	110	1630	50	150	1110	120	100	940	410	140	520	120
AMBIENT												
RELATED												
PROJECT												
TOTAL	110	1630	50	150	1110	120	100	940	410	140	520	120
LANE	1	3	1	2	3	1	1	2	1	2	2	1
Phasing	Prot-Fix		Auto	Prot-Fix		Auto	Prot-Fix		Auto	Prot-Fix		Auto
RTOR	Auto			Auto			Auto			Auto		

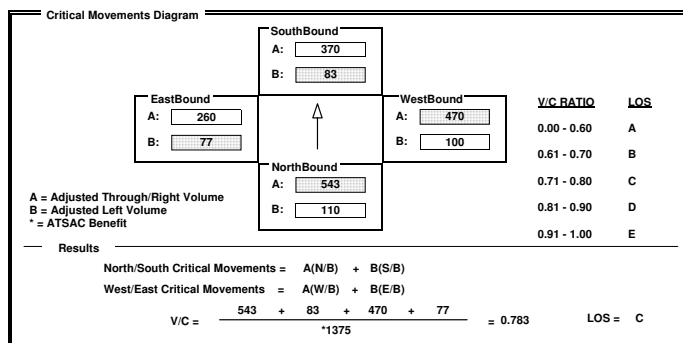

INTERSECTION DATA SUMMARY SHEET

N/S: Sepulveda Blvd W/E: Westchester Pkwy I/S No: 135
 AM/PM: AM Comments: Plus Project
 COUNT DATE: STUDY DATE: GROWTH FACTOR:

	NORTHBOUND			SOUTHBOUND			WESTBOUND			EASTBOUND		
	LT	TH	RT	LT	TH	RT	LT	TH	RT	LT	TH	RT
EXISTING	180	1810	60	190	1480	50	160	510	110	20	190	90
AMBIENT												
RELATED												
PROJECT												
TOTAL	180	1810	60	190	1480	50	160	510	110	20	190	90
LANE	1	3	1	1	3	1	2	2	1	1	2	1
SIGNAL	Prot-Fix	OLA	Prot-Fix	OLA	Prot-Fix	OLA	Prot-Fix	Auto	Prot-Fix	Auto	Prot-Fix	Auto

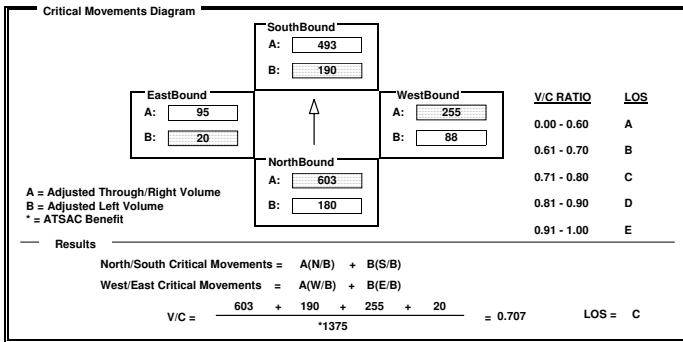

INTERSECTION DATA SUMMARY SHEET

N/S: Sepulveda Blvd W/E: 76th St/77th St I/S No: 136
 AM/PM: AM Comments: Plus Project
 COUNT DATE: STUDY DATE: GROWTH FACTOR:

	NORTHBOUND			SOUTHBOUND			WESTBOUND			EASTBOUND		
	LT	TH	RT	LT	TH	RT	LT	TH	RT	LT	TH	RT
EXISTING	50	2160	20	100	1310	210	30	140	250	600	50	60
AMBIENT												
RELATED												
PROJECT												
TOTAL	50	2160	20	100	1310	210	30	140	250	600	50	60
LANE	1	3	1	1	2	1	1	1	1	2	1	1
SIGNAL	Perm	Auto	Perm	Auto	Split	Auto	Split	Auto	Split	Auto	Split	Auto

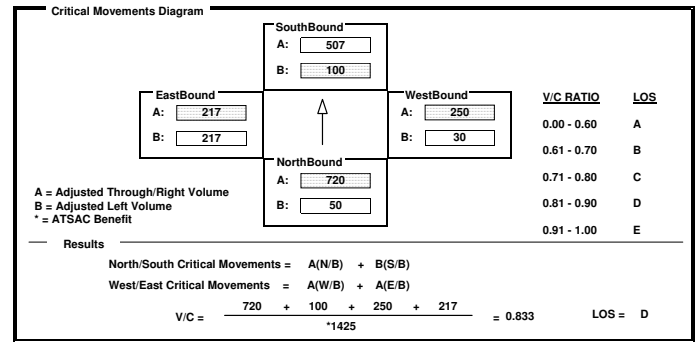

INTERSECTION DATA SUMMARY SHEET

N/S: Sepulveda Blvd W/E: I-105 WB Ramp I/S No: 139
 AM/PM: AM Comments: Plus Project
 COUNT DATE: STUDY DATE: GROWTH FACTOR:

	NORTHBOUND			SOUTHBOUND			WESTBOUND			EASTBOUND		
	LT	TH	RT	LT	TH	RT	LT	TH	RT	LT	TH	RT
EXISTING	0	2370	0	0	0	0	0	0	2240	0	0	0
AMBIENT												
RELATED												
PROJECT												
TOTAL	0	2370	0	0	0	0	0	0	2240	0	0	0
LANE		4							3			0
SIGNAL	Split	<none>	<none>	<none>	Split	<none>	<none>	<none>	<none>	Split	<none>	<none>

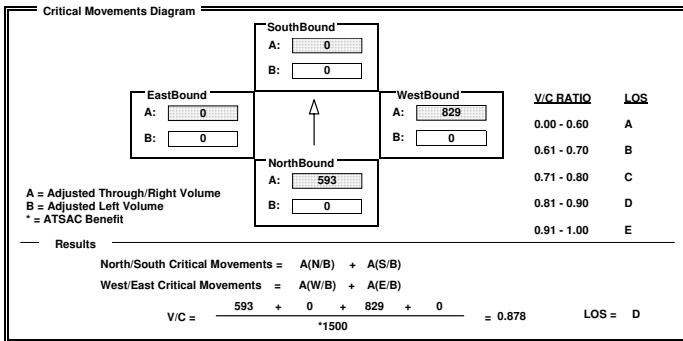

INTERSECTION DATA SUMMARY SHEET

N/S: Airport Blvd W/E: Westchester Blvd I/S No: 6
 AM/PM: MD Comments: Plus Project
 COUNT DATE: STUDY DATE: GROWTH FACTOR:

	NORTHBOUND			SOUTHBOUND			WESTBOUND			EASTBOUND		
	LT	TH	RT	LT	TH	RT	LT	TH	RT	LT	TH	RT
EXISTING	220	790	150	150	680	130	210	470	150	100	470	110
AMBIENT												
RELATED												
PROJECT												
TOTAL	220	790	150	150	680	130	210	470	150	100	470	110
LANE	2	2	1	1	3	1	2	1	1	1	2	1
SIGNAL	Prot-Fix	Auto	Prot-Fix	Auto	Prot-Fix	Auto	Prot-Fix	Auto	Prot-Fix	Auto	Prot-Fix	Auto

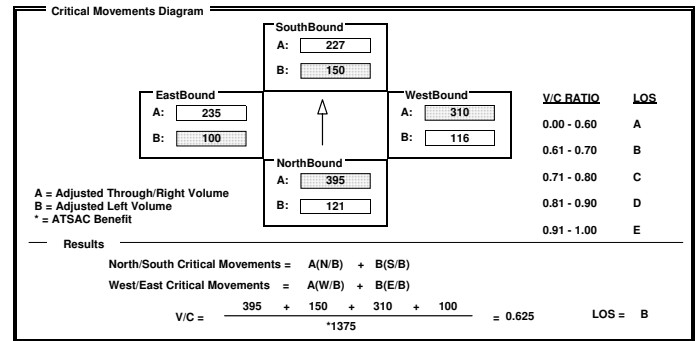

INTERSECTION DATA SUMMARY SHEET

N/S: Airport Blvd W/E: Century Blvd I/S No: 7
AM/PM: MD Comments: Plus Project
COUNT DATE: STUDY DATE: GROWTH FACTOR:

Volume/Lane/Signal Configurations table with columns for Northbound, Southbound, Westbound, Eastbound and rows for Existing, Ambient, Related, Project, Total, Lane, Phasing, RTOR, Signal.

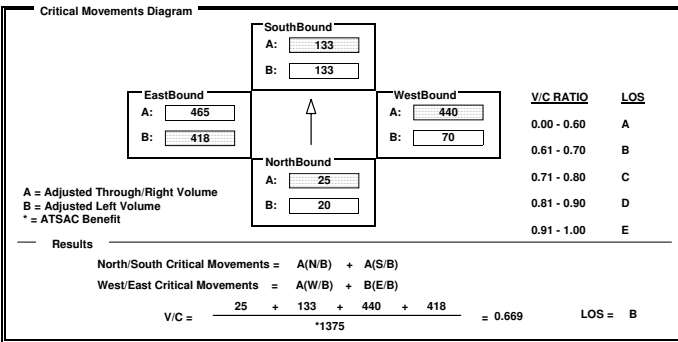

INTERSECTION DATA SUMMARY SHEET

N/S: Airport Blvd W/E: Manchester Ave I/S No: 9
AM/PM: MD Comments: Plus Project
COUNT DATE: STUDY DATE: GROWTH FACTOR:

Volume/Lane/Signal Configurations table with columns for Northbound, Southbound, Westbound, Eastbound and rows for Existing, Ambient, Related, Project, Total, Lane, Phasing, RTOR, Signal.

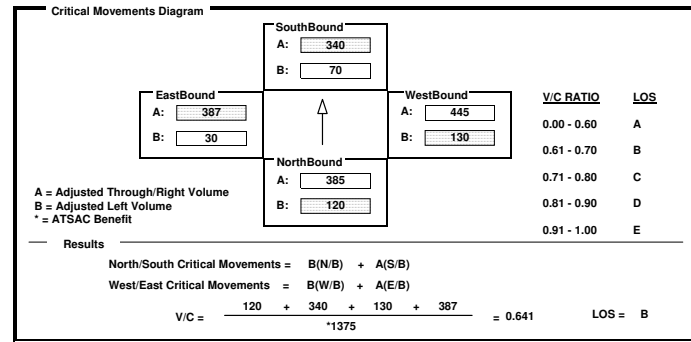

INTERSECTION DATA SUMMARY SHEET

N/S: Aviation Blvd W/E: Arbor Vitae St I/S No: 10
AM/PM: MD Comments: Plus Project
COUNT DATE: STUDY DATE: GROWTH FACTOR:

Volume/Lane/Signal Configurations table with columns for Northbound, Southbound, Westbound, Eastbound and rows for Existing, Ambient, Related, Project, Total, Lane, Phasing, RTOR, Signal.

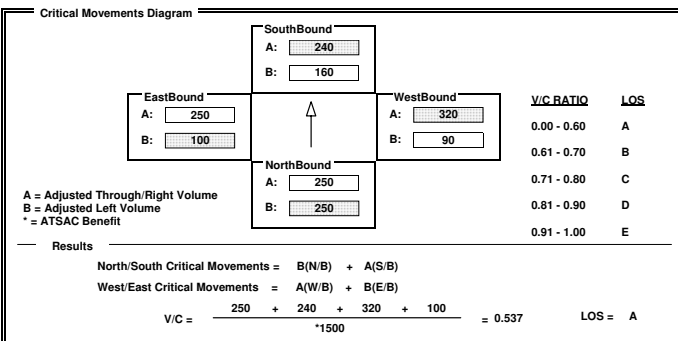

INTERSECTION DATA SUMMARY SHEET

N/S: Aviation Blvd W/E: Century Blvd I/S No: 14
AM/PM: MD Comments: Plus Project
COUNT DATE: STUDY DATE: GROWTH FACTOR:

Volume/Lane/Signal Configurations table with columns for Northbound, Southbound, Westbound, Eastbound and rows for Existing, Ambient, Related, Project, Total, Lane, Phasing, RTOR, Signal.

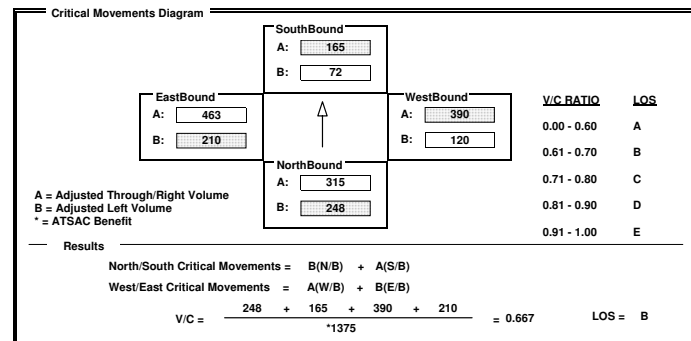

INTERSECTION DATA SUMMARY SHEET

N/S: W/E: I/S No:
 AM/PM: Comments:
 COUNT DATE: STUDY DATE: GROWTH FACTOR:

	NORTHBOUND			SOUTHBOUND			WESTBOUND			EASTBOUND		
	LT	TH	RT	LT	TH	RT	LT	TH	RT	LT	TH	RT
EXISTING	160	410	190	530	250	160	150	530	460	210	510	180
AMBIENT												
RELATED												
PROJECT												
TOTAL	160	410	190	530	250	160	150	530	460	210	510	180
LANE	2	2	1	2	2	1	2	3	1	2	3	1
SIGNAL	Prot-Fix	OLA	Prot-Fix	OLA	Prot-Fix	OLA	Prot-Fix	OLA	Prot-Fix	Auto	Prot-Fix	Auto

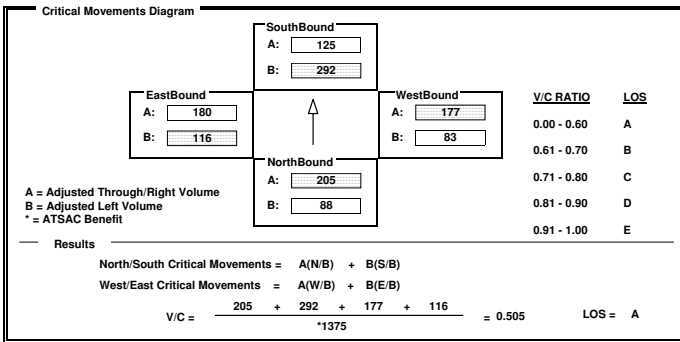

INTERSECTION DATA SUMMARY SHEET

N/S: W/E: I/S No:
 AM/PM: Comments:
 COUNT DATE: STUDY DATE: GROWTH FACTOR:

	NORTHBOUND			SOUTHBOUND			WESTBOUND			EASTBOUND		
	LT	TH	RT	LT	TH	RT	LT	TH	RT	LT	TH	RT
EXISTING	180	290	410	400	480	830	170	1080	390	130	1250	680
AMBIENT												
RELATED												
PROJECT												
TOTAL	180	290	410	400	480	830	170	1080	390	130	1250	680
LANE	1	2	2	2	2	2	1	3	1	1	3	1
SIGNAL	Prot-Fix	OLA	Prot-Fix	OLA	Prot-Fix	Auto	Prot-Fix	Auto	Prot-Fix	OLA	Prot-Fix	OLA

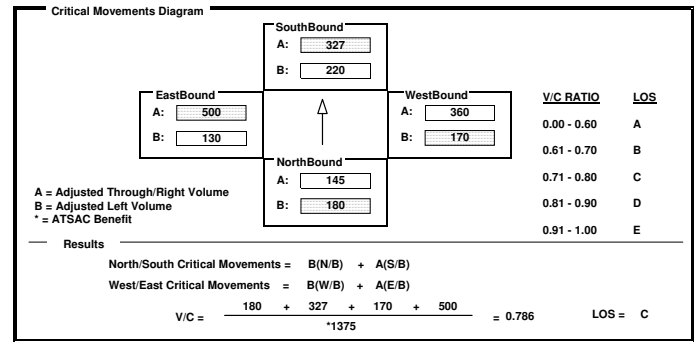

INTERSECTION DATA SUMMARY SHEET

N/S: W/E: I/S No:
 AM/PM: Comments:
 COUNT DATE: STUDY DATE: GROWTH FACTOR:

	NORTHBOUND			SOUTHBOUND			WESTBOUND			EASTBOUND		
	LT	TH	RT	LT	TH	RT	LT	TH	RT	LT	TH	RT
EXISTING	170	1420	920	600	1860	110	190	340	350	430	280	170
AMBIENT												
RELATED												
PROJECT												
TOTAL	170	1420	920	600	1860	110	190	340	350	430	280	170
LANE	1	3	2	2	3	1	2	2	2	2	3	1
SIGNAL	Prot-Fix	Auto	Prot-Fix	Auto	Prot-Fix	OLA	Prot-Fix	OLA	Prot-Fix	Auto	Prot-Fix	Auto

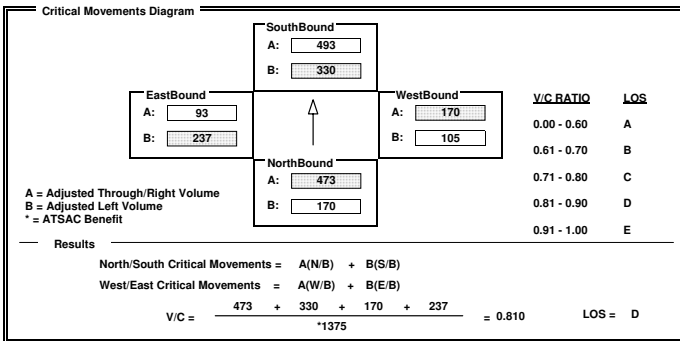

INTERSECTION DATA SUMMARY SHEET

N/S: W/E: I/S No:
 AM/PM: Comments:
 COUNT DATE: STUDY DATE: GROWTH FACTOR:

	NORTHBOUND			SOUTHBOUND			WESTBOUND			EASTBOUND		
	LT	TH	RT	LT	TH	RT	LT	TH	RT	LT	TH	RT
EXISTING	0	1750	120	0	1670	960	0	0	0	780	220	20
AMBIENT												
RELATED												
PROJECT												
TOTAL	0	1750	120	0	1670	960	0	0	0	780	220	20
LANE		2	1		3	2				3		1
SIGNAL	Perm	Auto	Perm	OLA	<none>	<none>	Split	Auto				

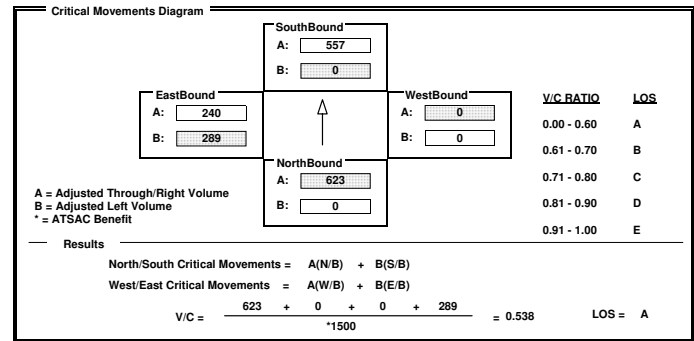

INTERSECTION DATA SUMMARY SHEET

N/S: La Cienega Blvd W/E: I-405 SB Ramps N/O Century I/S No: 96
AM/PM: MD Comments: Cumulative (2013) Plus Project
COUNT DATE: STUDY DATE: GROWTH FACTOR:

Volume/Lane/Signal Configurations table with columns for Northbound, Southbound, Westbound, Eastbound and rows for Existing, Ambient, Related, Project, Total, Lane, Phasing, RTOR, Signal.

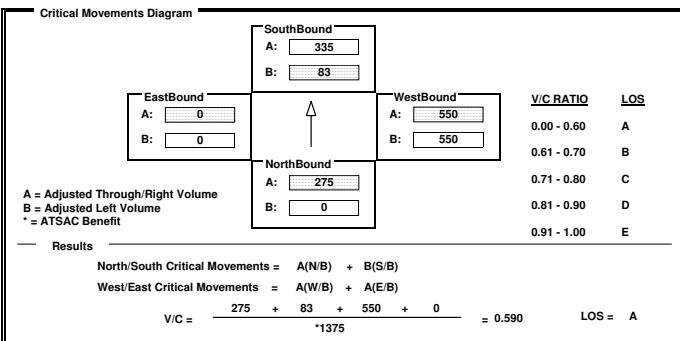

INTERSECTION DATA SUMMARY SHEET

N/S: Sepulveda Blvd W/E: La Tijera Blvd I/S No: 101
AM/PM: MD Comments: Plus Project
COUNT DATE: STUDY DATE: GROWTH FACTOR:

Volume/Lane/Signal Configurations table with columns for Northbound, Southbound, Westbound, Eastbound and rows for Existing, Ambient, Related, Project, Total, Lane, Phasing, RTOR, Signal.

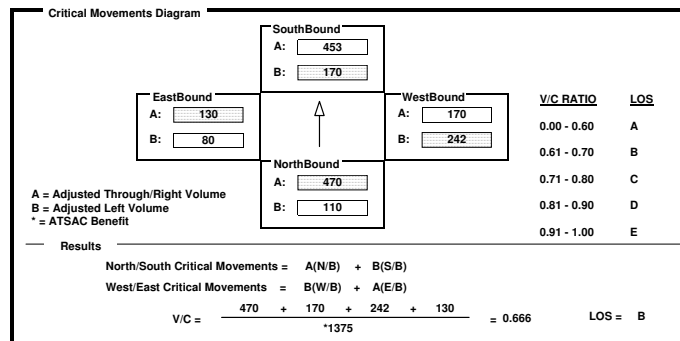

INTERSECTION DATA SUMMARY SHEET

N/S: Sepulveda Blvd W/E: Lincoln Blvd I/S No: 108
AM/PM: MD Comments: Plus Project
COUNT DATE: STUDY DATE: GROWTH FACTOR:

Volume/Lane/Signal Configurations table with columns for Northbound, Southbound, Westbound, Eastbound and rows for Existing, Ambient, Related, Project, Total, Lane, Phasing, RTOR, Signal.

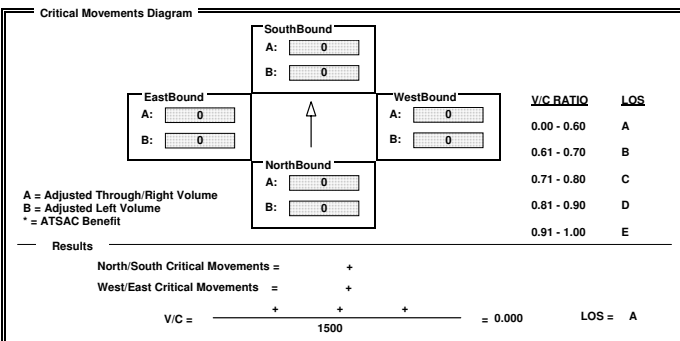

INTERSECTION DATA SUMMARY SHEET

N/S: Lincoln Blvd W/E: Venice Blvd I/S No: 109
AM/PM: MD Comments: Plus Project
COUNT DATE: STUDY DATE: GROWTH FACTOR:

Volume/Lane/Signal Configurations table with columns for Northbound, Southbound, Westbound, Eastbound and rows for Existing, Ambient, Related, Project, Total, Lane, Phasing, RTOR, Signal.

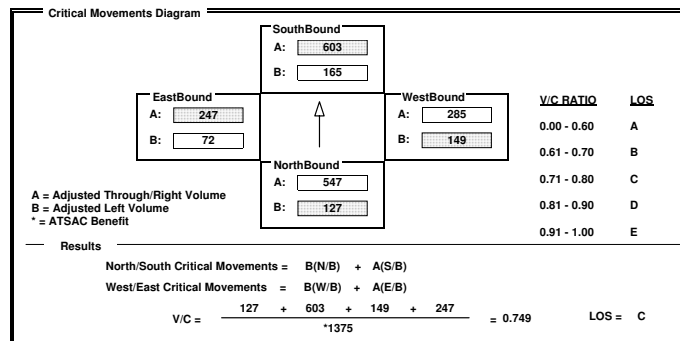

INTERSECTION DATA SUMMARY SHEET

N/S: Lincoln Blvd W/E: Washington Blvd I/S No: 110
 AM/PM: MD Comments: Plus Project
 COUNT DATE: STUDY DATE: GROWTH FACTOR:

	NORTHBOUND			SOUTHBOUND			WESTBOUND			EASTBOUND		
	LT	TH	RT	LT	TH	RT	LT	TH	RT	LT	TH	RT
EXISTING	330	1600	400	330	1570	170	330	740	390	170	640	970
AMBIENT												
RELATED												
PROJECT												
TOTAL	330	1600	400	330	1570	170	330	740	390	170	640	970
LANE	2	3	1	2	3	1	2	2	1	2	2	1
SIGNAL	Prot-Fix	Auto		Prot-Fix	Auto		Prot-Fix	OLA		Prot-Fix	OLA	

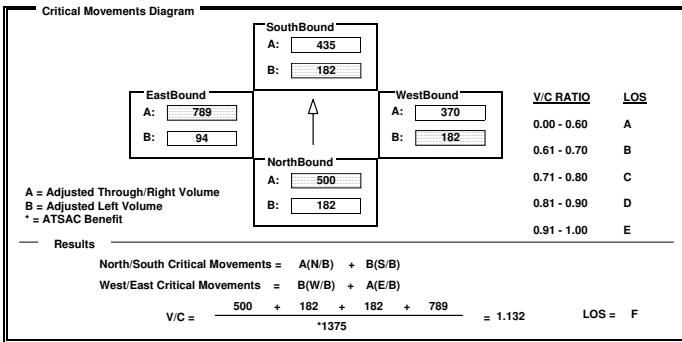

INTERSECTION DATA SUMMARY SHEET

N/S: Sepulveda Blvd W/E: Manchester Ave I/S No: 114
 AM/PM: MD Comments: Plus Project
 COUNT DATE: STUDY DATE: GROWTH FACTOR:

	NORTHBOUND			SOUTHBOUND			WESTBOUND			EASTBOUND		
	LT	TH	RT	LT	TH	RT	LT	TH	RT	LT	TH	RT
EXISTING	180	1080	150	240	1100	230	290	630	220	290	770	170
AMBIENT												
RELATED												
PROJECT												
TOTAL	180	1080	150	240	1100	230	290	630	220	290	770	170
LANE	1	3	1	2	3	1	1	2	1	2	2	1
SIGNAL	Prot-Fix	Auto		Prot-Fix	Auto		Prot-Fix	Auto		Prot-Fix	Auto	

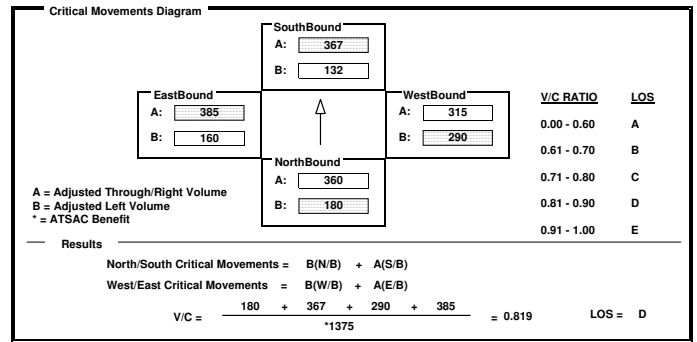

INTERSECTION DATA SUMMARY SHEET

N/S: Sepulveda Blvd W/E: Westchester Pkwy I/S No: 135
 AM/PM: MD Comments: Plus Project
 COUNT DATE: STUDY DATE: GROWTH FACTOR:

	NORTHBOUND			SOUTHBOUND			WESTBOUND			EASTBOUND		
	LT	TH	RT	LT	TH	RT	LT	TH	RT	LT	TH	RT
EXISTING	210	1460	100	100	1530	70	220	340	140	60	190	120
AMBIENT												
RELATED												
PROJECT												
TOTAL	210	1460	100	100	1530	70	220	340	140	60	190	120
LANE	1	3	1	1	3	1	2	2	1	1	2	1
SIGNAL	Prot-Fix	OLA		Prot-Fix	OLA		Prot-Fix	Auto		Prot-Fix	Auto	

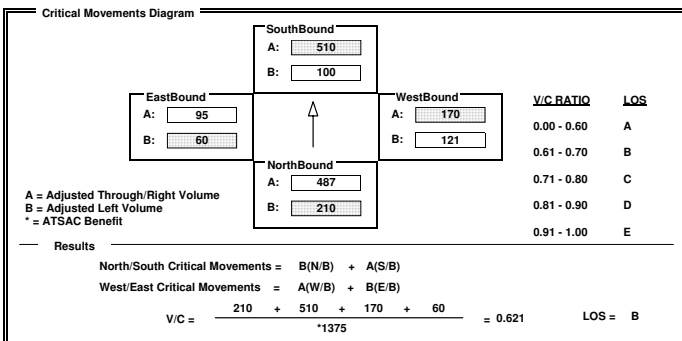

INTERSECTION DATA SUMMARY SHEET

N/S: Sepulveda Blvd W/E: 76th St/77th St I/S No: 136
 AM/PM: MD Comments: Plus Project
 COUNT DATE: STUDY DATE: GROWTH FACTOR:

	NORTHBOUND			SOUTHBOUND			WESTBOUND			EASTBOUND		
	LT	TH	RT	LT	TH	RT	LT	TH	RT	LT	TH	RT
EXISTING	60	1560	40	80	1620	330	40	80	90	260	70	60
AMBIENT												
RELATED												
PROJECT												
TOTAL	60	1560	40	80	1620	330	40	80	90	260	70	60
LANE	1	3	1	1	2	1	0	1	1	1	2	1
SIGNAL	Perm	Auto		Perm	Auto		Split	Auto		Split	Auto	

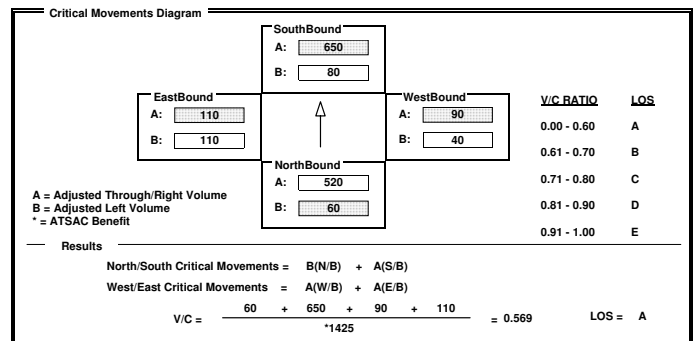

INTERSECTION DATA SUMMARY SHEET

N/S: Sepulveda Blvd W/E: I-105 WB Ramp I/S No: 139
AM/PM: MD Comments: Plus Project
COUNT DATE: STUDY DATE: GROWTH FACTOR:

Volume/Lane/Signal Configurations table with columns for Northbound, Southbound, Westbound, Eastbound and rows for Existing, Ambient, Related, Project, Total, Lane, and Signal.

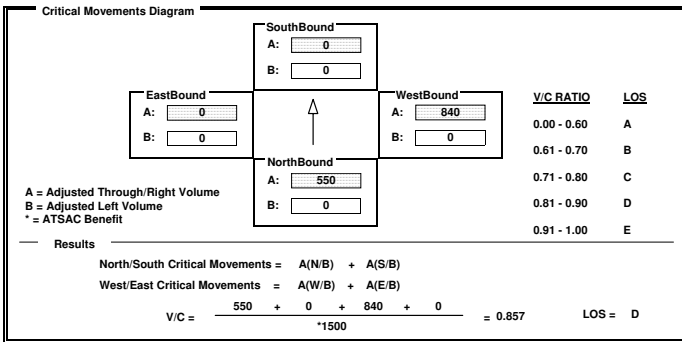

INTERSECTION DATA SUMMARY SHEET

N/S: Airport Blvd W/E: Westchester Blvd I/S No: 6
AM/PM: PM Comments: Plus Project
COUNT DATE: STUDY DATE: GROWTH FACTOR:

Volume/Lane/Signal Configurations table with columns for Northbound, Southbound, Westbound, Eastbound and rows for Existing, Ambient, Related, Project, Total, Lane, and Signal.

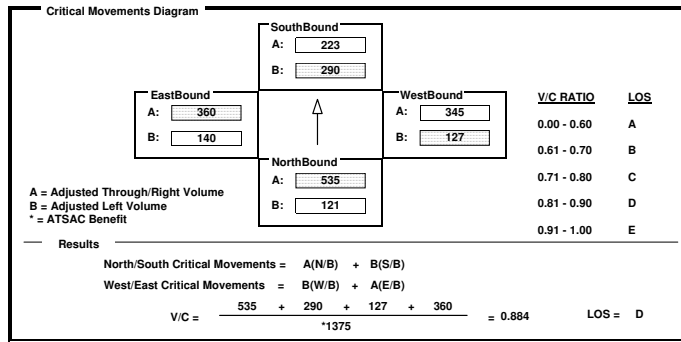

INTERSECTION DATA SUMMARY SHEET

N/S: Airport Blvd W/E: Century Blvd I/S No: 7
AM/PM: PM Comments: Plus Project
COUNT DATE: STUDY DATE: GROWTH FACTOR:

Volume/Lane/Signal Configurations table with columns for Northbound, Southbound, Westbound, Eastbound and rows for Existing, Ambient, Related, Project, Total, Lane, and Signal.

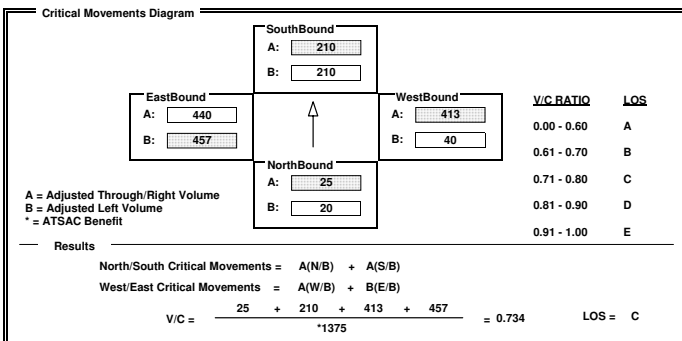

INTERSECTION DATA SUMMARY SHEET

N/S: Airport Blvd W/E: Manchester Ave I/S No: 9
AM/PM: PM Comments: Plus Project
COUNT DATE: STUDY DATE: GROWTH FACTOR:

Volume/Lane/Signal Configurations table with columns for Northbound, Southbound, Westbound, Eastbound and rows for Existing, Ambient, Related, Project, Total, Lane, and Signal.

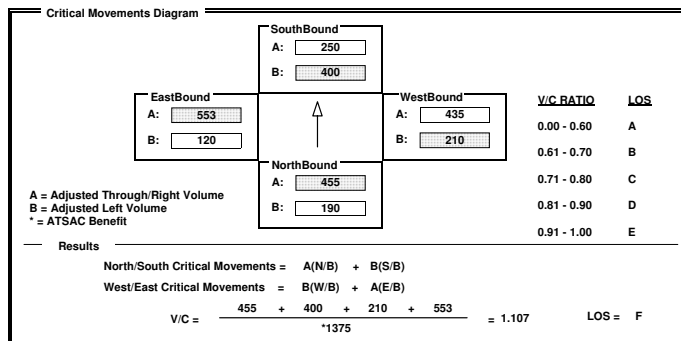

INTERSECTION DATA SUMMARY SHEET

N/S: W/E: I/S No:

AM/PM: Comments:

COUNT DATE: STUDY DATE: GROWTH FACTOR:

	NORTHBOUND			SOUTHBOUND			WESTBOUND			EASTBOUND		
	LT	TH	RT	LT	TH	RT	LT	TH	RT	LT	TH	RT
EXISTING	250	740	130	110	460	150	110	520	70	150	1220	320
AMBIENT												
RELATED												
PROJECT												
TOTAL	250	740	130	110	460	150	110	520	70	150	1220	320
LANE	1	2	1	1	1	1	1	1	1	1	2	1
SIGNAL	Phasing: Perm	RTOR: Auto		Phasing: Perm	RTOR: Auto		Phasing: Perm	RTOR: Auto		Phasing: Perm	RTOR: Auto	

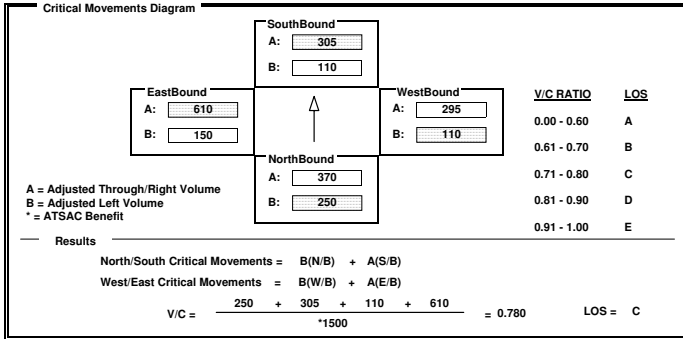

INTERSECTION DATA SUMMARY SHEET

N/S: W/E: I/S No:

AM/PM: Comments:

COUNT DATE: STUDY DATE: GROWTH FACTOR:

	NORTHBOUND			SOUTHBOUND			WESTBOUND			EASTBOUND		
	LT	TH	RT	LT	TH	RT	LT	TH	RT	LT	TH	RT
EXISTING	560	680	90	170	540	190	110	1550	140	250	1930	500
AMBIENT												
RELATED												
PROJECT												
TOTAL	560	680	90	170	540	190	110	1550	140	250	1930	500
LANE	2	1	1	2	2	1	1	4	1	1	4	1
SIGNAL	Phasing: Prot-Fix	RTOR: Auto		Phasing: Prot-Fix	RTOR: OLA		Phasing: Prot-Fix	RTOR: Auto		Phasing: Prot-Fix	RTOR: Auto	

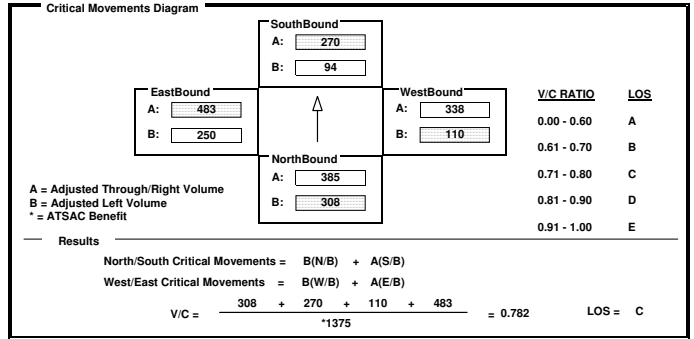

INTERSECTION DATA SUMMARY SHEET

N/S: W/E: I/S No:

AM/PM: Comments:

COUNT DATE: STUDY DATE: GROWTH FACTOR:

	NORTHBOUND			SOUTHBOUND			WESTBOUND			EASTBOUND		
	LT	TH	RT	LT	TH	RT	LT	TH	RT	LT	TH	RT
EXISTING	220	610	610	450	780	110	410	450	370	230	1110	380
AMBIENT												
RELATED												
PROJECT												
TOTAL	220	610	610	450	780	110	410	450	370	230	1110	380
LANE	2	2	1	2	2	1	2	3	1	2	3	1
SIGNAL	Phasing: Prot-Fix	RTOR: OLA		Phasing: Prot-Fix	RTOR: OLA		Phasing: Prot-Fix	RTOR: OLA		Phasing: Prot-Fix	RTOR: Auto	

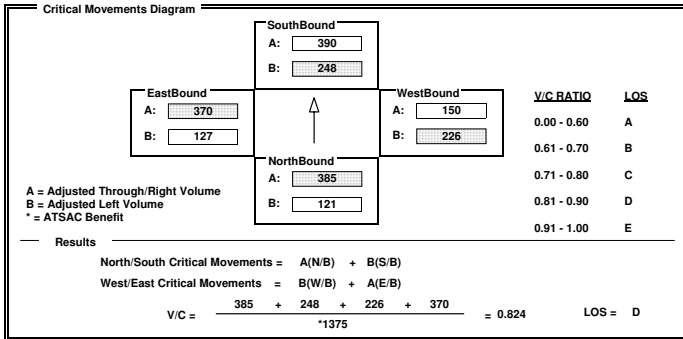

INTERSECTION DATA SUMMARY SHEET

N/S: W/E: I/S No:

AM/PM: Comments:

COUNT DATE: STUDY DATE: GROWTH FACTOR:

	NORTHBOUND			SOUTHBOUND			WESTBOUND			EASTBOUND		
	LT	TH	RT	LT	TH	RT	LT	TH	RT	LT	TH	RT
EXISTING	220	410	630	600	570	530	120	930	260	190	1340	960
AMBIENT												
RELATED												
PROJECT												
TOTAL	220	410	630	600	570	530	120	930	260	190	1340	960
LANE	1	2	2	2	2	2	1	3	1	1	3	1
SIGNAL	Phasing: Prot-Fix	RTOR: OLA		Phasing: Prot-Fix	RTOR: OLA		Phasing: Prot-Fix	RTOR: Auto		Phasing: Prot-Fix	RTOR: OLA	

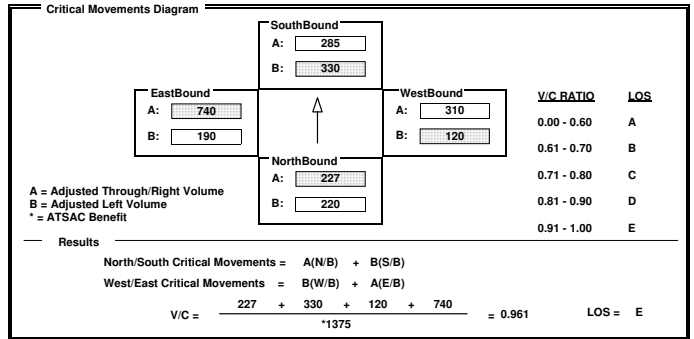

INTERSECTION DATA SUMMARY SHEET

N/S: Sepulveda Blvd W/E: Imperial Hwy I/S No: 71
AM/PM: PM Comments: Plus Project
COUNT DATE: STUDY DATE: GROWTH FACTOR:

Volume/Lane/Signal Configurations table with columns for Northbound, Southbound, Westbound, Eastbound and rows for Existing, Ambient, Related, Project, Total, Lane, Phasing, RTOR, Signal.

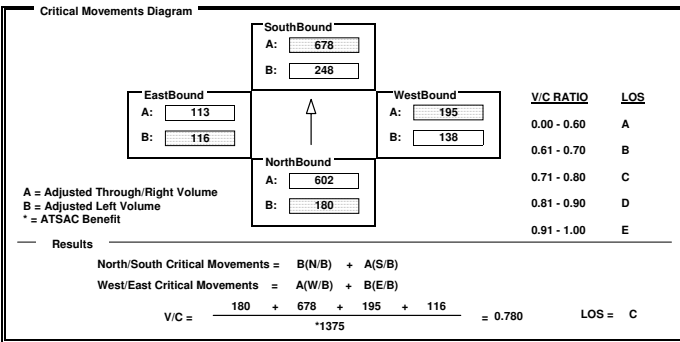

INTERSECTION DATA SUMMARY SHEET

N/S: La Cienega Blvd W/E: La Tijera Blvd I/S No: 88
AM/PM: PM Comments: Plus Project
COUNT DATE: STUDY DATE: GROWTH FACTOR:

Volume/Lane/Signal Configurations table with columns for Northbound, Southbound, Westbound, Eastbound and rows for Existing, Ambient, Related, Project, Total, Lane, Phasing, RTOR, Signal.

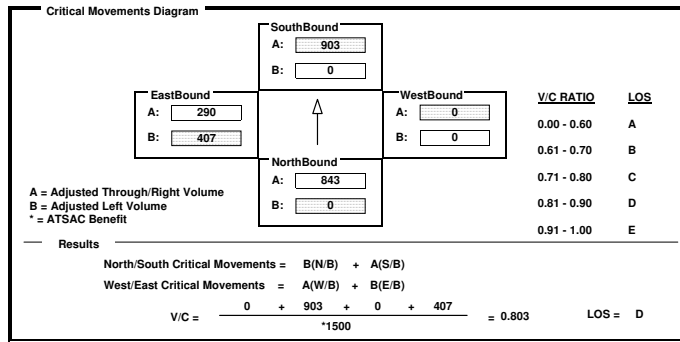

INTERSECTION DATA SUMMARY SHEET

N/S: La Cienega Blvd W/E: I-405 SB Ramps N/O Century I/S No: 96
AM/PM: PM Comments: Cumulative (2013) Plus Project
COUNT DATE: STUDY DATE: GROWTH FACTOR:

Volume/Lane/Signal Configurations table with columns for Northbound, Southbound, Westbound, Eastbound and rows for Existing, Ambient, Related, Project, Total, Lane, Phasing, RTOR, Signal.

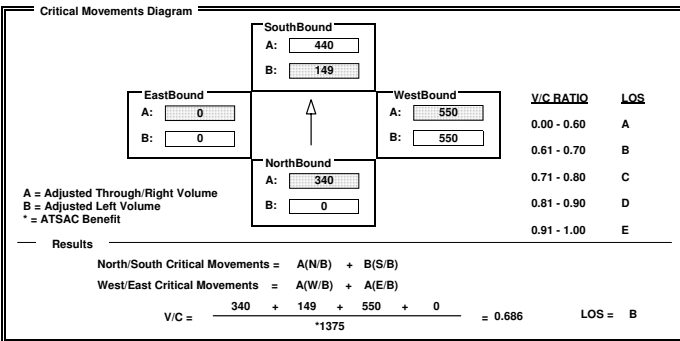

INTERSECTION DATA SUMMARY SHEET

N/S: Sepulveda Blvd W/E: La Tijera Blvd I/S No: 101
AM/PM: PM Comments: Plus Project
COUNT DATE: STUDY DATE: GROWTH FACTOR:

Volume/Lane/Signal Configurations table with columns for Northbound, Southbound, Westbound, Eastbound and rows for Existing, Ambient, Related, Project, Total, Lane, Phasing, RTOR, Signal.

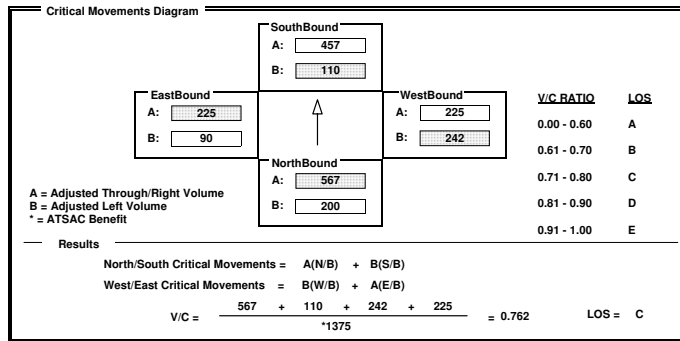

INTERSECTION DATA SUMMARY SHEET

N/S: W/E: I/S No:
 AM/PM: Comments:
 COUNT DATE: STUDY DATE: GROWTH FACTOR:

	NORTHBOUND			SOUTHBOUND			WESTBOUND			EASTBOUND		
	LT	TH	RT	LT	TH	RT	LT	TH	RT	LT	TH	RT
EXISTING	1500	2030	450	0	2250	10	0	0	10	0	0	1710
AMBIENT												
RELATED												
PROJECT												
TOTAL	1500	2030	450	0	2250	10	0	0	10	0	0	1710
LANE	4	2	1		3	1			1			4
SIGNAL	Prot-Fix	Auto		<none>	Auto		<none>	Auto		<none>	Auto	

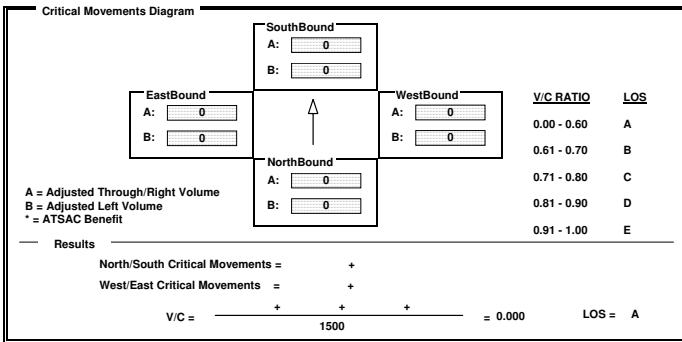

INTERSECTION DATA SUMMARY SHEET

N/S: W/E: I/S No:
 AM/PM: Comments:
 COUNT DATE: STUDY DATE: GROWTH FACTOR:

	NORTHBOUND			SOUTHBOUND			WESTBOUND			EASTBOUND		
	LT	TH	RT	LT	TH	RT	LT	TH	RT	LT	TH	RT
EXISTING	250	1400	160	210	1560	50	270	740	270	160	970	390
AMBIENT												
RELATED												
PROJECT												
TOTAL	250	1400	160	210	1560	50	270	740	270	160	970	390
LANE	2	3	1	2	3	1	2	2	1	2	3	1
SIGNAL	Prot-Fix	Auto		Prot-Fix	Auto		Prot-Fix	OLA		Prot-Fix	OLA	

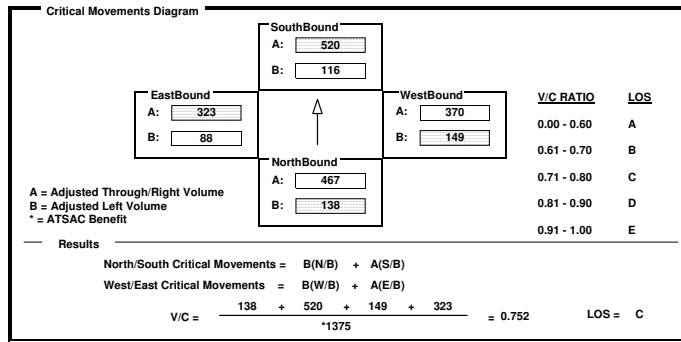

INTERSECTION DATA SUMMARY SHEET

N/S: W/E: I/S No:
 AM/PM: Comments:
 COUNT DATE: STUDY DATE: GROWTH FACTOR:

	NORTHBOUND			SOUTHBOUND			WESTBOUND			EASTBOUND		
	LT	TH	RT	LT	TH	RT	LT	TH	RT	LT	TH	RT
EXISTING	880	1570	250	200	1910	110	360	840	260	130	920	510
AMBIENT												
RELATED												
PROJECT												
TOTAL	880	1570	250	200	1910	110	360	840	260	130	920	510
LANE	2	3	1	2	3	1	2	2	1	2	2	1
SIGNAL	Prot-Fix	Auto		Prot-Fix	Auto		Prot-Fix	OLA		Prot-Fix	OLA	

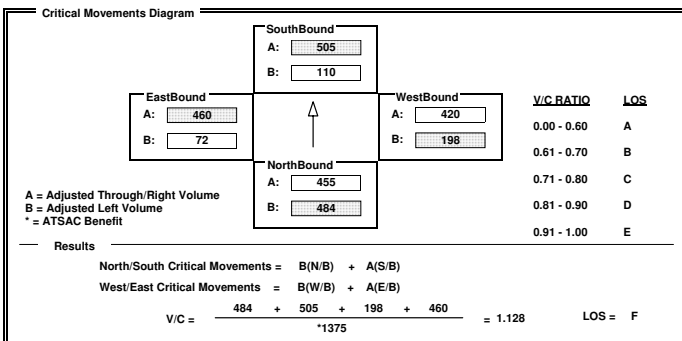

INTERSECTION DATA SUMMARY SHEET

N/S: W/E: I/S No:
 AM/PM: Comments:
 COUNT DATE: STUDY DATE: GROWTH FACTOR:

	NORTHBOUND			SOUTHBOUND			WESTBOUND			EASTBOUND		
	LT	TH	RT	LT	TH	RT	LT	TH	RT	LT	TH	RT
EXISTING	130	1500	90	350	1320	280	110	850	210	220	1050	140
AMBIENT												
RELATED												
PROJECT												
TOTAL	130	1500	90	350	1320	280	110	850	210	220	1050	140
LANE	1	3	1	2	3	1	1	2	1	2	2	1
SIGNAL	Prot-Fix	Auto		Prot-Fix	Auto		Prot-Fix	Auto		Prot-Fix	Auto	

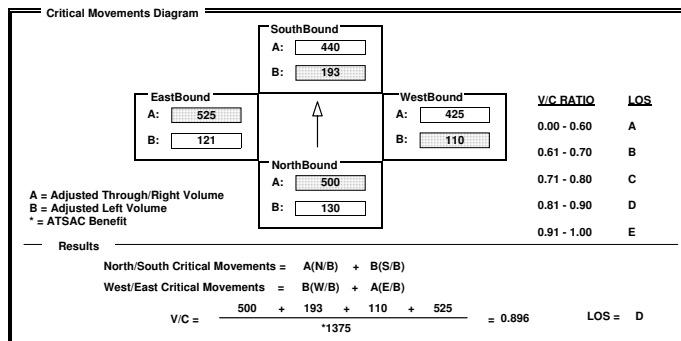

INTERSECTION DATA SUMMARY SHEET

N/S: Sepulveda Blvd W/E: Westchester Pkwy I/S No: 135
AM/PM: PM Comments: Plus Project
COUNT DATE: STUDY DATE: GROWTH FACTOR:

Volume/Lane/Signal Configurations table with columns for Northbound, Southbound, Westbound, Eastbound and rows for Existing, Ambient, Related, Project, Total, Lane, and Signal.

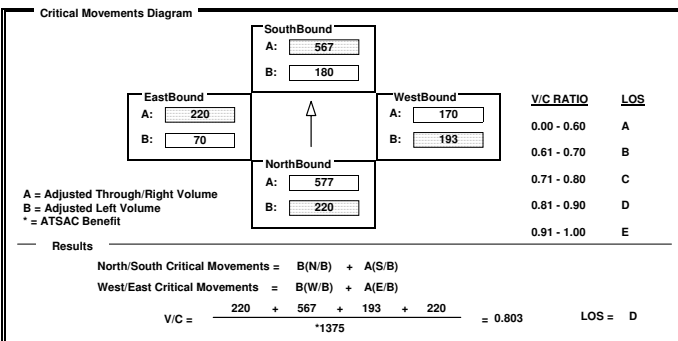

INTERSECTION DATA SUMMARY SHEET

N/S: Sepulveda Blvd W/E: 76th St/77th St I/S No: 136
AM/PM: PM Comments: Plus Project
COUNT DATE: STUDY DATE: GROWTH FACTOR:

Volume/Lane/Signal Configurations table with columns for Northbound, Southbound, Westbound, Eastbound and rows for Existing, Ambient, Related, Project, Total, Lane, and Signal.

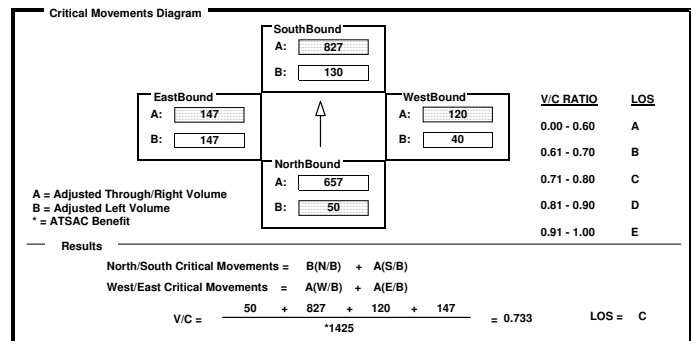

INTERSECTION DATA SUMMARY SHEET

N/S: Sepulveda Blvd W/E: I-105 WB Ramp I/S No: 139
AM/PM: PM Comments: Plus Project
COUNT DATE: STUDY DATE: GROWTH FACTOR:

Volume/Lane/Signal Configurations table with columns for Northbound, Southbound, Westbound, Eastbound and rows for Existing, Ambient, Related, Project, Total, Lane, and Signal.

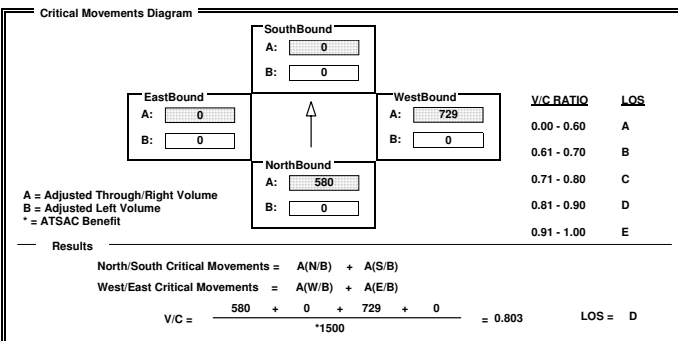

ICU Analysis table with columns for Approach, M/MT, Lanes, Volume, Capacity, V/C, and ICU Analysis. Includes sub-tables for AM, MD, and PM Peak Hours.

* - Denotes critical movement

INTERSECTION DATA SUMMARY SHEET

N/S: W/E: I/S No:

AM/PM: Comments:

COUNT DATE: STUDY DATE: GROWTH FACTOR:

Volume/Lane/Signal Configurations												
	NORTHBOUND			SOUTHBOUND			WESTBOUND			EASTBOUND		
	LT	TH	RT	LT	TH	RT	LT	TH	RT	LT	TH	RT
EXISTING	0	2310	810	150	0	0	1390	0	110	0	0	0
AMBIENT												
RELATED												
PROJECT												
TOTAL	0	2310	810	150	0	0	1390	0	110	0	0	0
LANE												
SIGNAL	Phasing		RTOR	Phasing		RTOR	Phasing		RTOR	Phasing		RTOR
	Prot-Fix		Free	Prot-Fix			Split		Free			

Critical Movements Diagram

Direction	A	B	V/C RATIO	LOS
EastBound	0	0	0.00 - 0.60	A
SouthBound	0	150	0.61 - 0.70	B
WestBound	0	765	0.71 - 0.80	C
NorthBound	770	0	0.81 - 0.90	D
			0.91 - 1.00	E

A = Adjusted Through/Right Volume
 B = Adjusted Left Volume
 * = ATSAC Benefit

Results
 North/South Critical Movements = $A(N/B) + B(S/B)$
 West/East Critical Movements = $B(W/B) + A(E/B)$
 $V/C = \frac{770 + 150 + 765 + 0}{1425} = 1.182$ LOS = F

INTERSECTION DATA SUMMARY SHEET

N/S: W/E: I/S No:

AM/PM: Comments:

COUNT DATE: STUDY DATE: GROWTH FACTOR:

Volume/Lane/Signal Configurations												
	NORTHBOUND			SOUTHBOUND			WESTBOUND			EASTBOUND		
	LT	TH	RT	LT	TH	RT	LT	TH	RT	LT	TH	RT
EXISTING	0	2580	1380	420	0	0	780	0	100	0	0	0
AMBIENT												
RELATED												
PROJECT												
TOTAL	0	2580	1380	420	0	0	780	0	100	0	0	0
LANE												
SIGNAL	Phasing		RTOR	Phasing		RTOR	Phasing		RTOR	Phasing		RTOR
	Prot-Fix		Free	Prot-Fix			Split		Free			

Critical Movements Diagram

Direction	A	B	V/C RATIO	LOS
EastBound	0	0	0.00 - 0.60	A
SouthBound	0	420	0.61 - 0.70	B
WestBound	0	429	0.71 - 0.80	C
NorthBound	860	0	0.81 - 0.90	D
			0.91 - 1.00	E

A = Adjusted Through/Right Volume
 B = Adjusted Left Volume
 * = ATSAC Benefit

Results
 North/South Critical Movements = $A(N/B) + B(S/B)$
 West/East Critical Movements = $B(W/B) + A(E/B)$
 $V/C = \frac{860 + 420 + 429 + 0}{1425} = 1.199$ LOS = F

Appendix C-6
LAX Bradley West Project Draft EIR

CMP Freeway Analysis

May 2009

Prepared for:

Los Angeles World Airports
One World Way
Los Angeles, California 90045

Prepared by:

Fehr & Peers Transportation Consultants
201 Santa Monica Boulevard, Suite 500
Santa Monica, CA 90401

Appendix C-7
LAX Bradley West Project Draft EIR

**Estimated Airport-Related Vehicle Trip
Generation for Off-Airport Intersection Analysis**

May 2009

Prepared for:

Los Angeles World Airports
One World Way
Los Angeles, California 90045

Prepared by:

Ricondo & Associates, Inc.
20 North Clark Street, Suite 1500
Chicago, IL 60602

**ESTIMATED AIRPORT-RELATED VEHICLE TRIP GENERATION FOR
OFF-AIRPORT INTERSECTION ANALYSIS**

TBIT Reconfiguration Project EIR

LAWA is in the process of initiating the preparation of an Environmental Impact Report (EIR) in support of the Tom Bradley International Terminal (TBIT) Reconfiguration Project (the Project). The TBIT Reconfiguration Project will result in terminal building and aircraft apron and taxiway improvements to accommodate new aircraft contact gates on the west side of the TBIT. These contact gates will essentially replace hardstand positions where aircraft park remotely and passengers are bused between the terminal building and these remote aircraft parking positions. In addition, the Federal Inspection Services (FIS) facilities within the TBIT are being improved to provide more efficient processing of international arrivals passengers.

The roadway traffic trip generation analysis described in this document is based on a review of the existing (August 2008) arriving and departing airline passenger schedules. These 24-hour schedules have been adjusted using passenger show-up profiles and simulation to convert the scheduled airline passenger activity from passengers “at the gate” to passengers “at the landside/curbside”. The resultant passenger data is then compared with hourly traffic volumes entering and exiting the Central Terminal Area (CTA) roadways in order to establish a relationship between airline passenger activity and roadway trips during a typical Friday in August. This relationship is then used to project future peak hour roadway trips based on future airline schedules representing the “With Project” and “Without Project” conditions during the future 2013 horizon year.

It is anticipated that the aircraft arrivals and departures time schedules for the TBIT and other CTA terminals for the future “With Project” and “Without Project” conditions would be essentially the same. The scheduled aircraft would also be the same except for minor differences pertaining to the “downsizing” of four aircraft from an Airbus A-380 to a smaller Boeing 777 under the “Without Project” condition due to taxiway limitations that would preclude the larger A-380 aircraft from accessing certain TBIT gates if the Project were not constructed.

Given the similarities in aircraft schedules for the “With” and “Without Project” conditions, it is not anticipated that the TBIT improvements described above would affect the number of daily airline passengers that would access the TBIT or any of the other terminal buildings in the CTA during the future 2013 year being analyzed for this EIR. Subsequently, it is anticipated that the daily airline passenger volumes for the “With Project” and “Without Project” conditions would be essentially the same. Based on this assumption, it is estimated that the daily roadway traffic volumes between the two future conditions would also be approximately the same.

Roadway traffic analysis is based on peak hour traffic volumes. Because the implementation of the Project would not have an effect on airline passenger activity at the other (non-TBIT) terminals, it is anticipated that the hourly roadway traffic volumes accessing the other terminals would be the same under the “With Project” and “Without Project” scenarios. Furthermore, it is anticipated that the Project would not affect the TBIT departures schedule times as compared with the “Without Project” condition.

The anticipated differences between the “With Project” and “Without Project” condition are summarized below:

- **TBIT Arrivals Passengers**—As described previously, it is anticipated that the TBIT improvements will include new contact gates that will allow passengers to process off the aircraft at a faster rate than can be accomplished when passengers are required to use an airfield bus to travel from a remotely parked aircraft to access the TBIT. Furthermore, it is anticipated that the improved arrivals process will allow a more efficient passenger processing through the TBIT building as compared with the existing FIS facilities. Although the improved processing rate at the TBIT will not have an affect on daily passenger activity, it is anticipated that the more rapid processing rate could have an affect on the peaking at the curbside and external roadway system.
- **TBIT Employees**—The TBIT building is being expanded to include more building square footage, which implies an increase in employment activity.

The results of the trip generation analysis prepared by Ricondo & Associates, Inc., are summarized in the following sections.

I. Passenger Schedule Analysis

Exhibits 1 through 9 depict estimated rolling hourly passenger originations and terminations for TBIT, other Terminals, and overall. General analysis assumptions consist of:

- August 2008 and future year (2013) passenger schedules for the “With Project” and “Without Project” scenarios were developed by Ricondo & Associates, Inc.
- Scheduled arriving and departing aircraft “seats” are converted to O&D passengers by applying historical O&D percentages detailed from the FAA’s 10 percent survey sample (on a carrier-by-carrier basis) and estimated load factors. Different O&D and load factor assumptions were applied for domestic and international passengers.
- For TBIT arrivals, airline passenger activity at the curbside was directly calculated from passenger simulations performed by Jacobs Consultancy.
- For TBIT departures and for the other terminals were calculated by applying earliness of arrival and lateness of departure distributions to the O&D traffic to convert from passengers “at the gate” to passengers “at curbside”. The passenger show-up profiles were based on information obtained from the 2006 airline passenger survey.

Summary comments on the exhibits include:

- Because the hourly volumes represent “rolling” hourly volumes, the activity represented in the vertical bars that are one-hour wide represent the hourly traffic volumes occurring over a two-hour period. For example, the a.m. bar is shown from 8:00 to 9:00 a.m. The point on the left bar represents the hourly volume from 7:00 to 8:00 a.m., a point in the middle of the band would represent the time from 7:30 to 8:30 a.m., and the right bar would represent the

time from 8:00 to 9:00 a.m. As a result, the overall period represents activity from 7:00 a.m. to 9:00 a.m.

- As shown within **Exhibit 1**, there is an additional 150 daily terminating passengers at TBIT in 2013 under the Project scenario.
- As shown within **Exhibit 4**, there is an additional 129 daily originating passengers at TBIT in 2013 under the Project scenario.
- During the passenger peak periods at TBIT, the passenger activity under the “With Project” scenario is shown to precede the peak for the “Without Project” scenario, and the activity is more peaked due to the enhanced processing capability resulting from the TBIT improvements.
- The passenger distributions at the other passenger terminals are shown to be identical.

II. CTA Trip Generation

Tables 1 through **6** summarize the analysis of airline passenger activity and the relationship with CTA traffic volume activity.

- **Table 1** summarizes daily passenger activity for TBIT, other terminals, and total airport.
- **Tables 2** and **3** provide hourly CTA inbound and outbound vehicle counts on Friday, August 15, 2008. The Airport passenger peak periods are noted within the tables. The a.m. and p.m. peak periods are concurrent with the commuter periods, and the mid-day band is consistent with the historical mid-day Airport peak period.
- **Table 4** summarizes the origin-destination passengers by time-of-day and by terminal. The values highlighted in the table correlate with the CTA volumes highlighted in the previous tables.
- **Table 5** summarizes the break down of originations and terminations for the AM Peak, PM Peak, and Midday Peak periods. The passenger activity has been further refined to depict the allocation of activity related to TBIT and other terminals.
- Projected peak hour CTA trips are summarized in **Table 6**. The volumes are estimated utilizing historical data on originations per upper level vehicle and terminations per lower level vehicle. The ratios of originating and terminating passengers per vehicle determined for 2008 are assumed to be constant through the 2013 future year.

III. Overall Trip Generation

Tables 7 through 12 summarize total trip generation for key airport functions comprised of CTA, Airport public parking, Airport employee parking, rental car, off-Airport public parking and cargo.

General analysis assumptions include:

- The LAX Trip General Driveway Counts for August 2008, collected by Quality Traffic Data for LAWA, were used as a basis for the non-CTA trip analysis. This database provides traffic driveway counts for five main areas: airport public parking lots, airport employee parking, cargo facilities, rental car facilities, and off-airport parking facilities. The counts are detailed separately for cars, trucks, and shuttles.
- Traffic associated with the airport public parking, rental car facilities, and off-airport parking is assumed to increase in proportion to increases in peak hour O&D passenger activity described in the previous tables and exhibits.
- As described previously, it is anticipated that the Project will result in a larger TBIT building which will, in turn, result in an increase in employment within that building. In order to estimate the potential affect of the increased size of the TBIT on employment traffic volumes, it was necessary to estimate the number of employees entering and exiting the remote employee parking lots during the three peak hours that are employed in the TBIT. The TBIT employment is then broken down by functional classification given that all TBIT employment would not increase at the same rates.
- Peak hour traffic associated with TBIT employees was estimated based on a parking lot survey conducted by LAWA at Employee Lot D North and Lot E on November 19, 2008, and again at Lot D North on December 3, 2008. Specifically, the survey was used to estimate the percentage of employees, by functional classification, entering and exiting the lot at the three peak hours of the day. Employees entering the lot were asked a series of questions to determine if they worked at TBIT and, if so, which of the following five categories represented their employment: Airlines, Concessions, Security, Maintenance/Custodial, and Other. It was assumed that the employment distribution for inbound traffic would apply for outbound traffic. The survey results are summarized in **Table 7**.
- The assumptions used to estimate the change in TBIT-related employee traffic in 2013 compared with existing 2008 conditions were based on the following:
 - Security employee traffic was assumed to increase in proportion to forecast growth in daily aircraft operations at the TBIT.
 - Concession employee traffic was assumed to increase in proportion to the change in TBIT building square footage dedicated for concessions.
 - The Maintenance/Custodial employee traffic was assumed to increase in proportion to the change in total TBIT building square footage.

- Airline employee growth and other employee traffic were assumed to increase in proportion to the average growth in daily airline passenger and aircraft operations associated with the TBIT.
- Non-TBIT airport employees are assumed to increase based on the average growth of daily O&D passenger and daily aircraft operations at the Airport.
- Cargo traffic is assumed to increase in proportion to the growth in annual cargo tonnage.

Exhibit 1: Terminating Passenger Flow at Curbside (Rolling 60-min)
Tom Bradley International Terminal (TBIT)

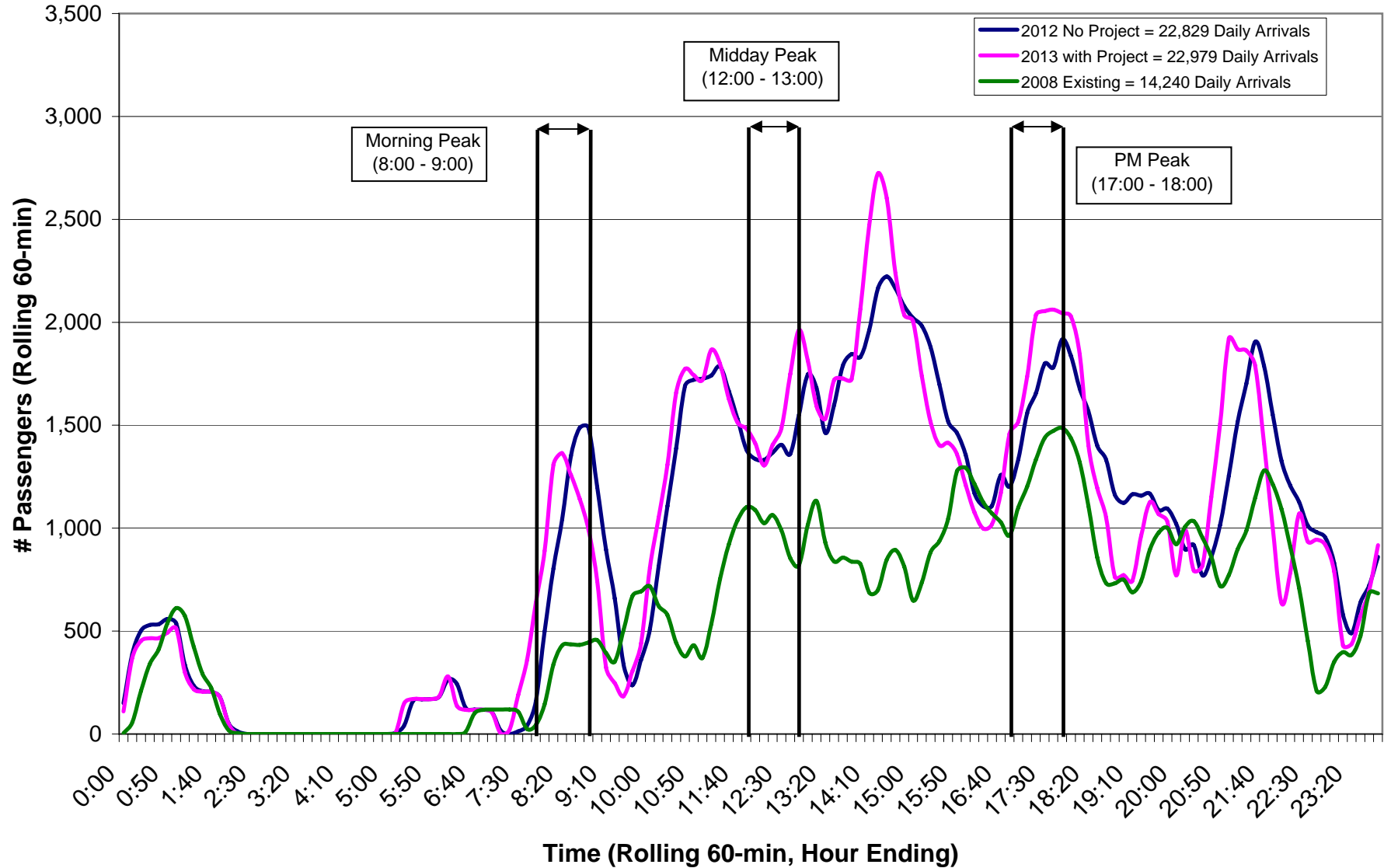

Sources: Jacobs Consultancy (Terminal Simulation); Ricondo Associates, Inc. (Passenger Schedules)
Prepared by: Ricondo Associates, Inc. (November 2008)

Exhibit 2: Terminating Passenger Flow at Curbside (Rolling 60-min)

Other Arriving Passengers (i.e. Total - TBIT)

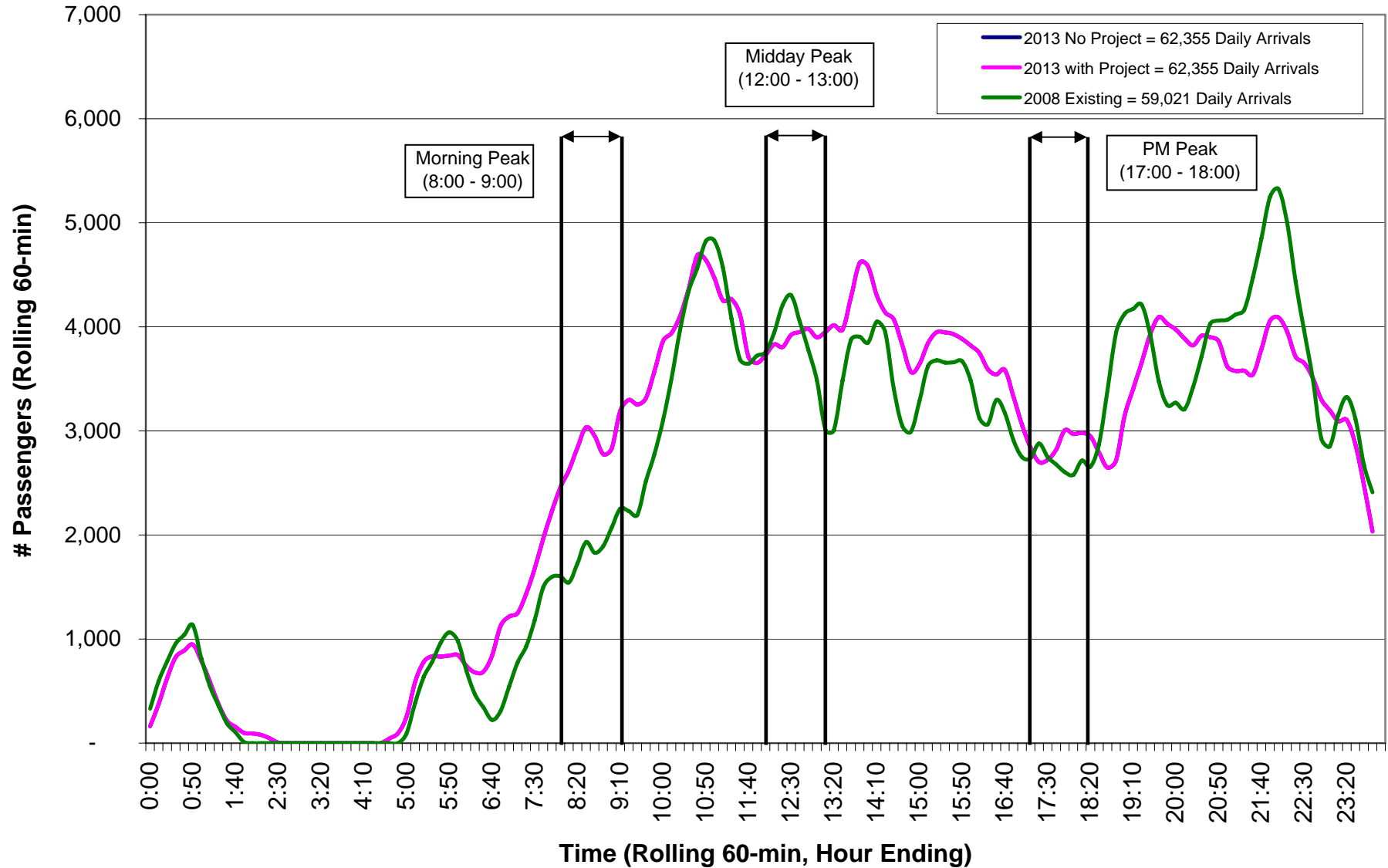

Source: Ricondo Associates, Inc.

Prepared by: Ricondo Associates, Inc. (November 2008)

Exhibit 3: Terminating Passenger Flow at Curbside (Rolling 60-min)
Total Arriving Passengers

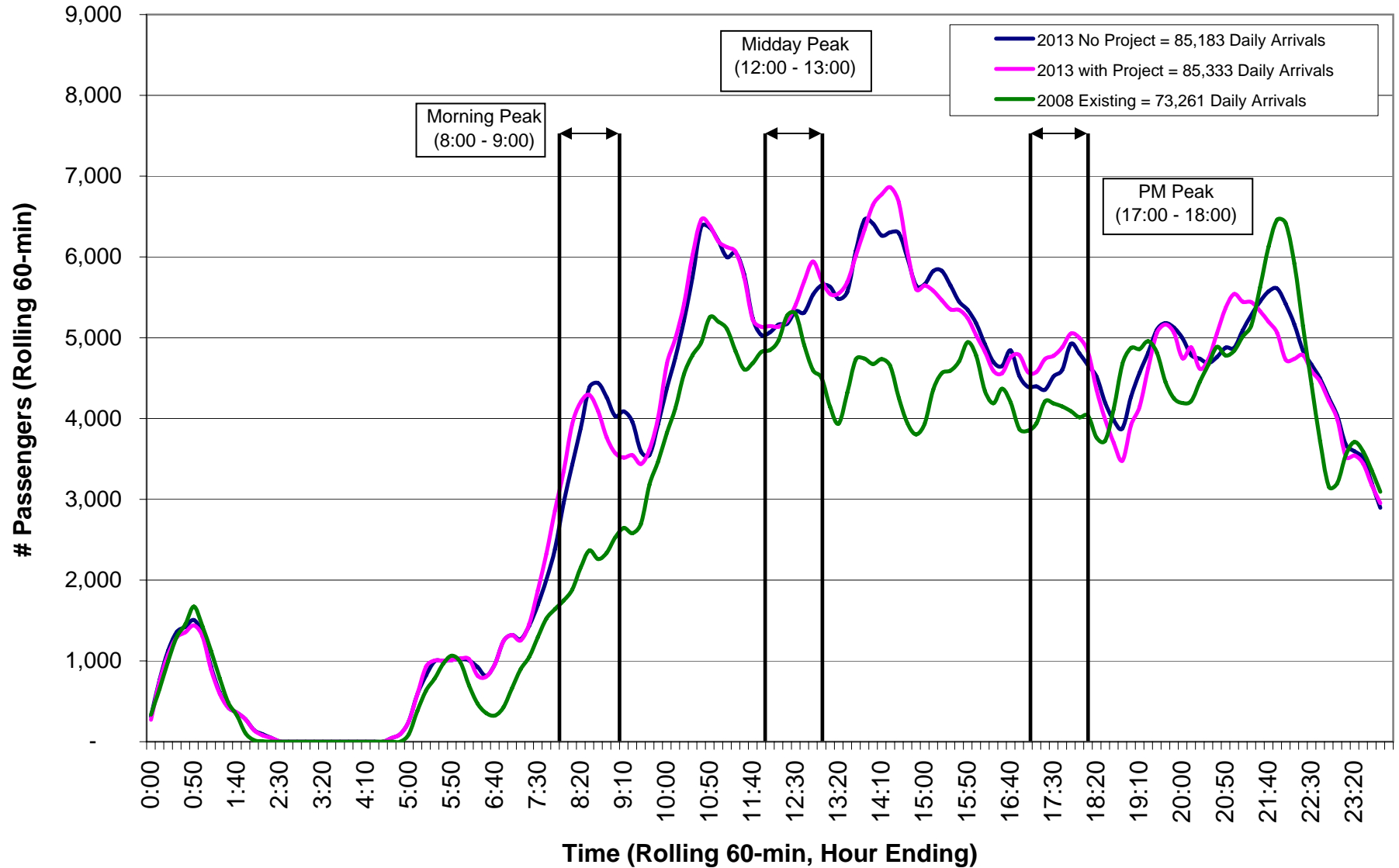

Sources: Jacobs Consultancy (TBIT Simulation); Ricondo Associates, Inc. (Passenger Schedules)
 Prepared by: Ricondo Associates, Inc. (November 2008)

Exhibit 4: Departing Passenger Flow at Curbside (Rolling 60-min)
 Tom Bradley International Terminal (TBIT)

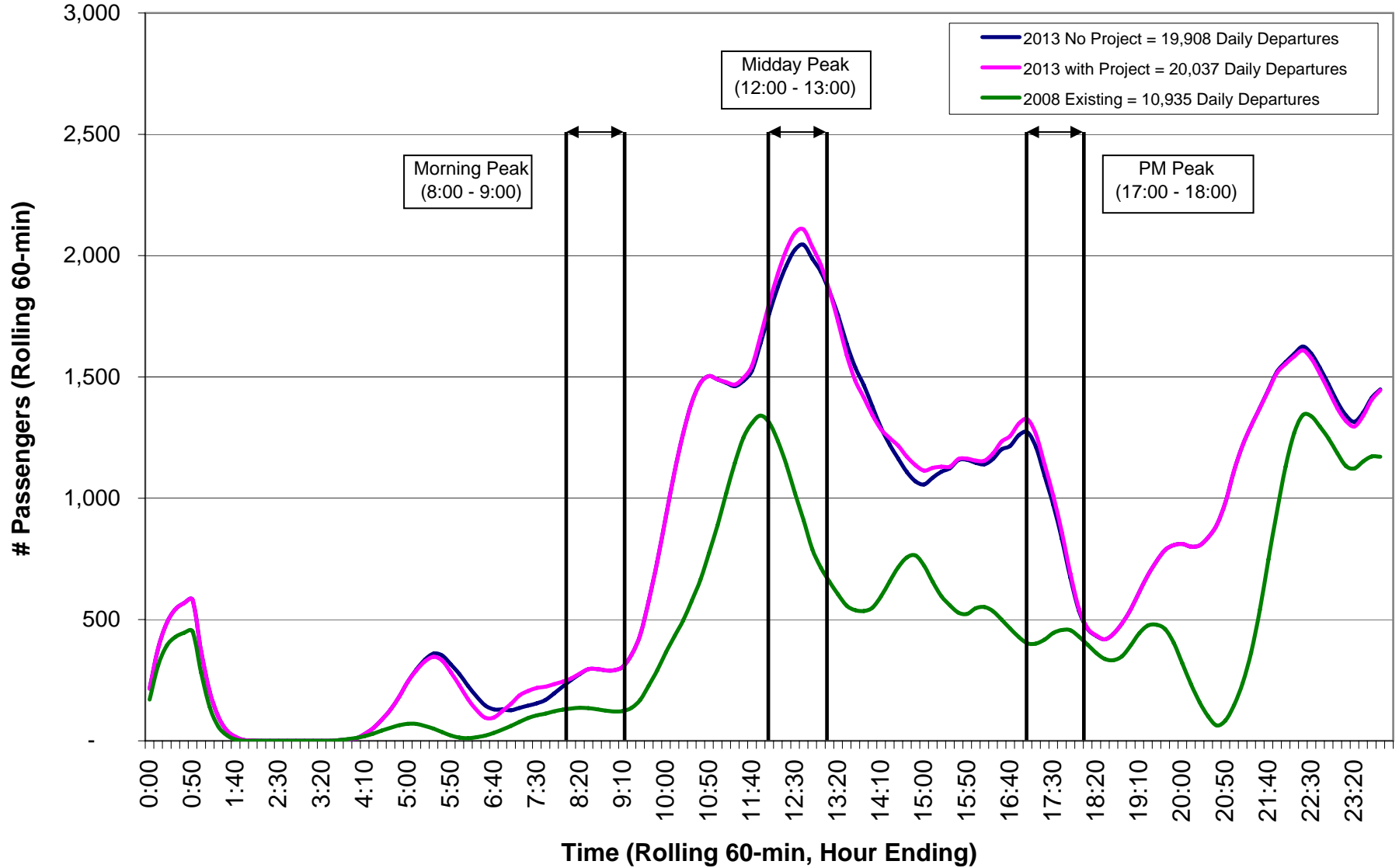

Source: Ricondo Associates, Inc.
 Prepared by: Ricondo Associates, Inc. (November 2008)

Exhibit 5: Departing Passenger Flow at Curbside (Rolling 60-min)

Other Departing Passengers (i.e. Total - TBIT)

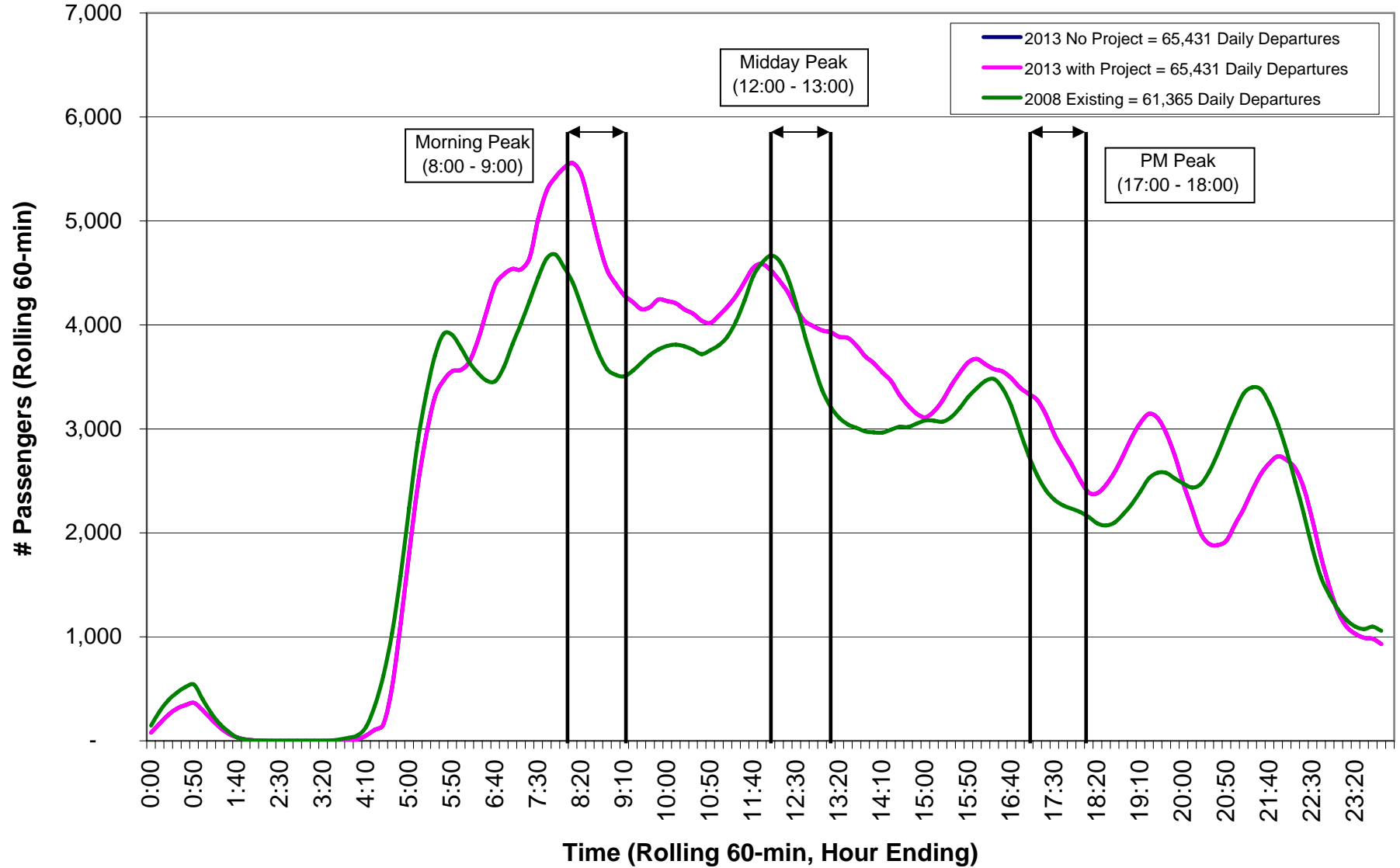

Source: Ricondo Associates, Inc.

Prepared by: Ricondo Associates, Inc. (November 2008)

Exhibit 6: Departing Passenger Flow at Curbside (Rolling 60-min)

Total Departing Passengers

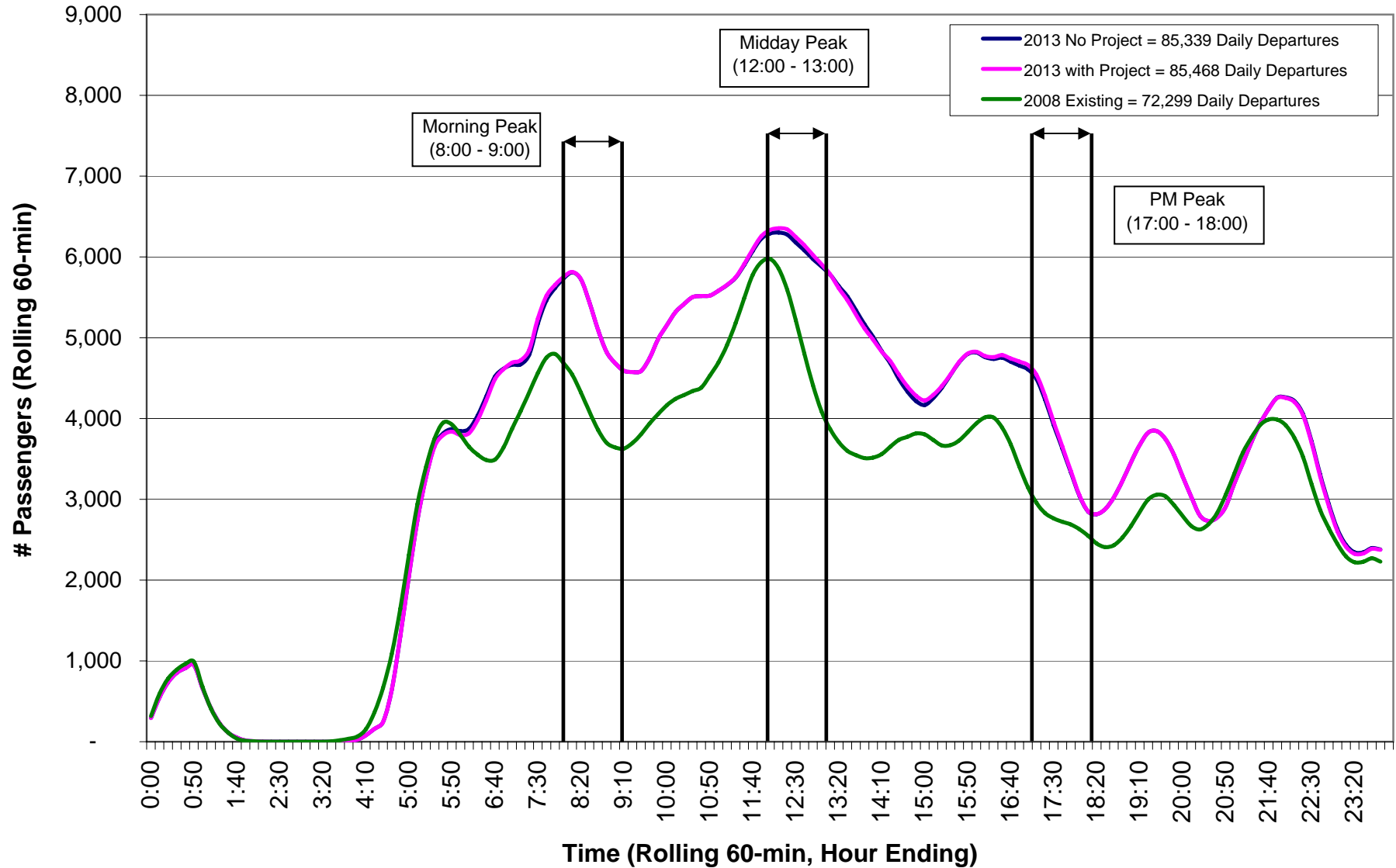

Source: Ricondo Associates, Inc.

Prepared by: Ricondo Associates, Inc. (November 2008)

Exhibit 7: Total TBIT Passenger Flow at Curbside (Rolling 60-min)

Total TBIT Passengers



Exhibit 8: Total Other Passenger Flow at Curbside (Rolling 60-min)

Total Other Passengers

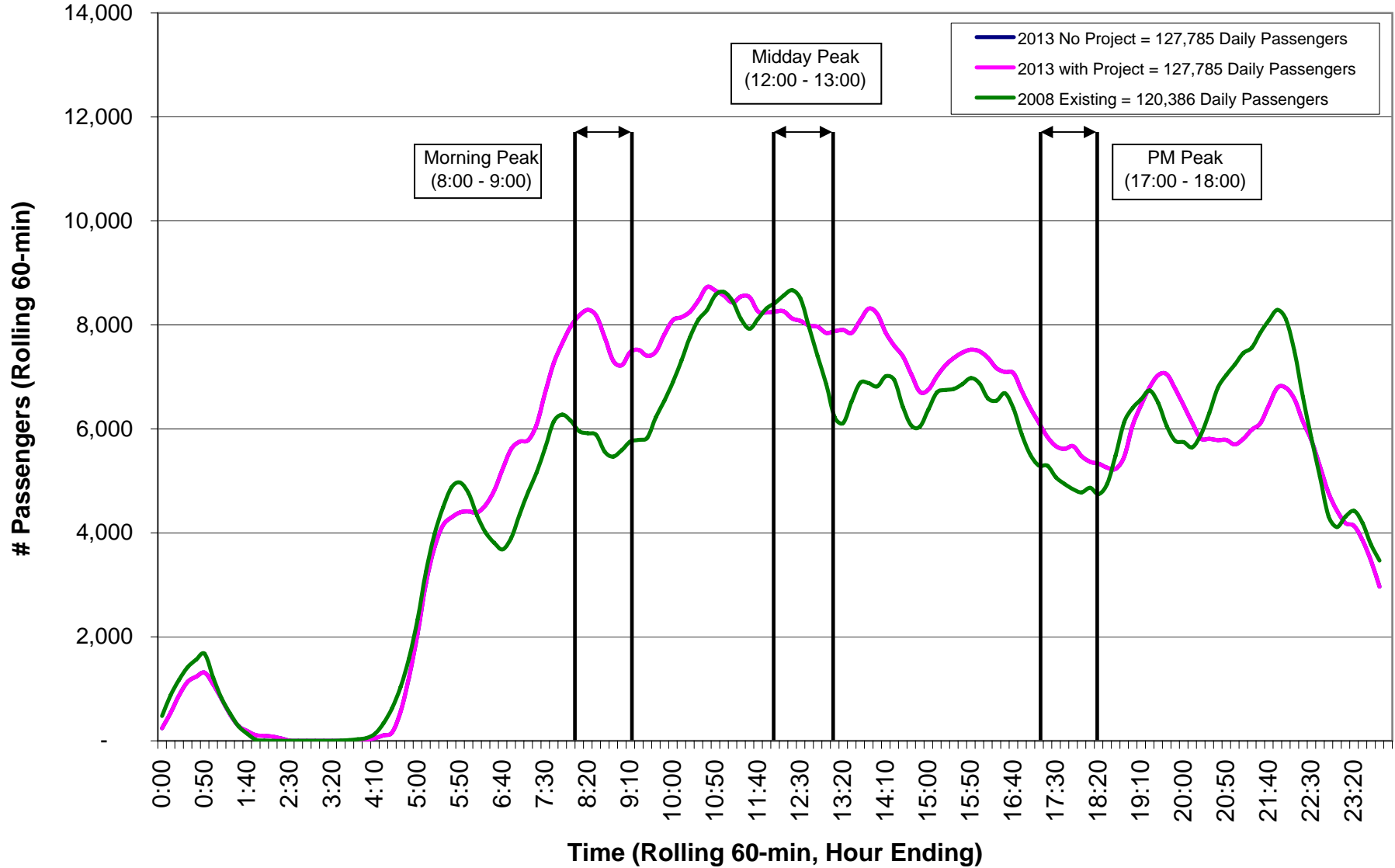

Source: Ricondo Associates, Inc.

Prepared by: Ricondo Associates, Inc. (November 2008)

Exhibit 9: Total Passenger Flow at Curbside (Rolling 60-min)

Total Passengers

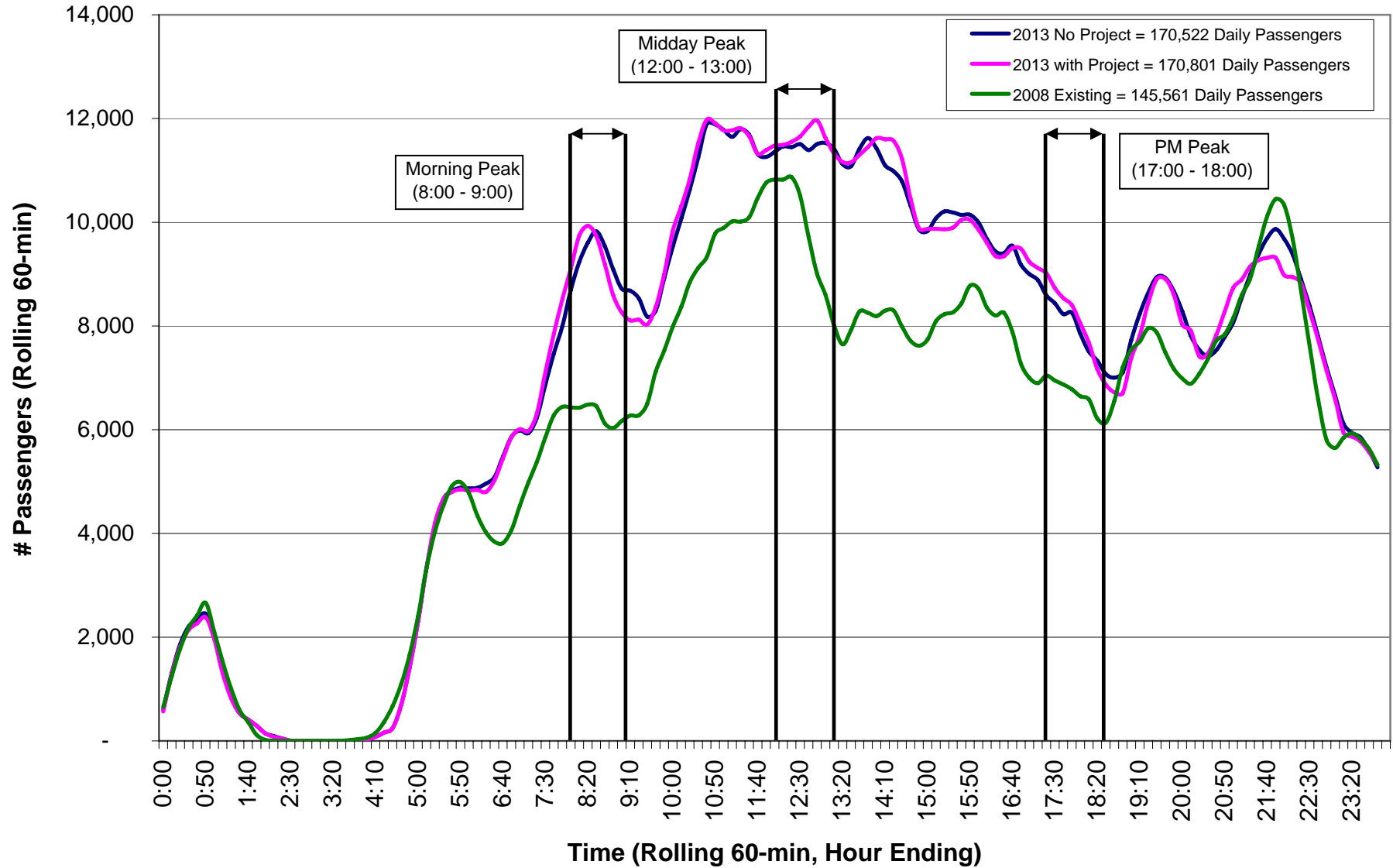

Sources: Jacobs Consultancy (Simulation of TBIT Terminations); Ricondo Associates, Inc. (All Other Analysis)
 Prepared by: Ricondo Associates, Inc. (November 2008)

Table 1

Total Daily Passengers

Scenario	Originations			Terminations			Total		
	TBIT	Other	Total	TBIT	Other	Total	TBIT	Other	Total
2008	10,935	61,365	72,299	14,240	59,021	73,261	25,175	120,386	145,561
2013 w/	20,037	65,431	85,468	22,979	62,355	85,333	43,016	127,785	170,801
2013 w/o	19,908	65,431	85,339	22,829	62,355	85,183	42,737	127,785	170,522
Total Growth									
2008 vs. 2013 w/	183.2%	106.6%	118.2%	161.4%	105.6%	116.5%	170.9%	106.1%	117.3%
2008 vs. 2013 w/o	182.1%	106.6%	118.0%	160.3%	105.6%	116.3%	169.8%	106.1%	117.1%

Source: Ricondo & Associates, Inc.

Prepared by: Ricondo & Associates, Inc. (November 2008)

Table 2**Hourly Inbound Upper & Lower Level Vehicle Counts (August 2008)**

Start Time	Lower Level	Percent of Day	Upper Level	Percent of Day	Total	Percent of Day	
0:00	1,140	2.9%	367	0.9%	1,507	1.8%	
1:00	644	1.6%	236	0.6%	880	1.1%	
2:00	262	0.7%	171	0.4%	433	0.5%	
3:00	304	0.8%	421	1.0%	725	0.9%	
4:00	458	1.2%	1,605	3.8%	2,063	2.5%	
5:00	662	1.7%	2,399	5.6%	3,061	3.7%	
6:00	696	1.7%	2,564	6.0%	3,260	4.0%	
7:00	897	2.3%	2,399	5.6%	3,296	4.0%	
8:00	1,175	3.0%	2,319	5.5%	3,494	4.2%	Morning Peak
9:00	1,530	3.8%	2,376	5.6%	3,906	4.7%	
10:00	2,083	5.2%	2,560	6.0%	4,643	5.6%	
11:00	2,233	5.6%	2,554	6.0%	4,787	5.8%	Midday Peak
12:00	2,420	6.1%	2,227	5.2%	4,647	5.6%	
13:00	2,078	5.2%	1,889	4.4%	3,967	4.8%	
14:00	2,332	5.9%	2,072	4.9%	4,404	5.4%	
15:00	2,179	5.5%	1,919	4.5%	4,098	5.0%	
16:00	2,030	5.1%	1,611	3.8%	3,641	4.4%	
17:00	2,029	5.1%	1,620	3.8%	3,649	4.4%	PM Peak
18:00	2,203	5.5%	1,795	4.2%	3,998	4.9%	
19:00	2,407	6.1%	2,037	4.8%	4,444	5.4%	
20:00	2,590	6.5%	2,265	5.3%	4,855	5.9%	
21:00	2,937	7.4%	2,138	5.0%	5,075	6.2%	
22:00	2,582	6.5%	2,014	4.7%	4,596	5.6%	
23:00	1,909	4.8%	918	2.2%	2,827	3.4%	
Daily Total	39,780	100.0%	42,476	100.0%	82,256	100.0%	

Note: Data collected on Friday August 15, 2008.

Source: Los Angeles World Airports

Prepared by: Ricondo & Associates, Inc. (November 2008)

Table 3

Hourly Outbound Upper & Lower Level Vehicle Counts (August 2008)

Start Time	Lower			Upper			Total			
	Center Way - Lower	Sepulveda SB - Lower	Skyway - Lower	Century - Upper	Sepulveda SB - Upper	Park One - Other	Lower	Upper	Total	
0:00	1,027	754	90	327	103	21	1,871	430	2,301	
1:00	759	524	84	253	51	13	1,367	304	1,671	
2:00	246	124	56	143	31	3	426	174	600	
3:00	209	95	63	173	75	9	367	248	615	
4:00	483	137	149	503	382	13	769	885	1,654	
5:00	753	243	194	883	620	20	1,190	1,503	2,693	
6:00	806	270	204	866	643	25	1,280	1,509	2,789	
7:00	1,015	480	233	869	629	24	1,728	1,498	3,226	
8:00	1,079	463	207	790	513	19	1,749	1,303	3,052	Morning Peak
9:00	1,305	573	238	804	590	23	2,116	1,394	3,510	
10:00	1,574	828	239	838	677	37	2,641	1,515	4,156	
11:00	1,962	1,144	241	952	699	31	3,347	1,651	4,998	Midday Peak
12:00	1,991	1,221	198	925	595	30	3,410	1,520	4,930	
13:00	1,786	1,116	186	909	477	34	3,088	1,386	4,474	
14:00	1,862	1,202	197	1,008	543	92	3,261	1,551	4,812	
15:00	1,942	1,153	234	925	524	44	3,329	1,449	4,778	
16:00	1,694	1,027	215	911	407	46	2,936	1,318	4,254	
17:00	1,663	1,155	200	823	377	51	3,018	1,200	4,218	PM Peak
18:00	1,589	956	166	873	405	47	2,711	1,278	3,989	
19:00	1,753	1,049	167	879	443	49	2,969	1,322	4,291	
20:00	1,957	1,188	140	1,118	504	55	3,285	1,622	4,907	
21:00	2,094	1,447	90	1,179	518	42	3,631	1,697	5,328	
22:00	2,126	1,455	135	863	530	55	3,716	1,393	5,109	
23:00	1,770	1,434	118	644	263	35	3,322	907	4,229	
Daily Total	33,445	20,038	4,044	18,458	10,599	818	57,527	29,057	86,584	

Note: Data collected on Friday August 15, 2008.

Source: Los Angeles World Airports

Prepared by: Ricondo & Associates, Inc. (November 2008)

Table 4**2008 O&D Passengers by Time of Day by Terminal**

Start Time	Originations			Terminations			Total		
	TBIT ¹	Other	Total	TBIT ¹	Other	Total	TBIT ¹	Other	Total
23:00	170	147	317	4	331	335	175	478	652
0:00	280	399	679	612	814	1,426	892	1,213	2,105
1:00	0	4	4	18	0	18	18	4	22
2:00	0	0	0	0	0	0	-	-	-
3:00	12	52	64	0	0	0	12	52	64
4:00	70	2,240	2,310	0	93	93	70	2,333	2,403
5:00	13	3,782	3,795	0	980	980	13	4,761	4,775
6:00	61	3,812	3,873	119	543	662	180	4,355	4,535
7:00	129	4,554	4,682	145	1,603	1,748	273	6,157	6,430
8:00	121	3,521	3,642	456	2,072	2,528	577	5,593	6,170
9:00	366	3,798	4,164	718	3,103	3,821	1,083	6,902	7,985
10:00	889	3,804	4,693	370	4,829	5,199	1,259	8,633	9,892
11:00	1,311	4,665	5,976	1,088	3,759	4,847	2,399	8,424	10,823
12:00	714	3,374	4,088	1,017	3,488	4,504	1,730	6,862	8,592
13:00	549	2,967	3,516	826	3,849	4,675	1,375	6,816	8,191
14:00	722	3,081	3,803	648	3,286	3,935	1,370	6,368	7,738
15:00	546	3,392	3,939	1,293	3,484	4,777	1,840	6,876	8,716
16:00	402	2,747	3,149	1,101	2,748	3,849	1,503	5,495	6,998
17:00	429	2,200	2,629	1,437	2,578	4,015	1,866	4,778	6,644
18:00	393	2,278	2,671	750	4,123	4,873	1,143	6,401	7,544
19:00	319	2,475	2,794	922	3,270	4,192	1,241	5,745	6,986
20:00	146	3,170	3,317	772	4,068	4,839	918	7,238	8,156
21:00	1,130	2,786	3,916	1,092	5,325	6,417	2,222	8,111	10,333
22:00	1,186	1,261	2,446	350	2,851	3,201	1,536	4,111	5,647

Morning Peak**Midday Peak****PM Peak**

Note: Earliness and lateness distributions are applied to passenger schedules.

¹ Includes O&D passengers at West Remote Gates

Sources: Jacobs Consultancy (TBIT terminations)

Ricondo & Associates, Inc (all other passenger data)

Prepared by: Ricondo & Associates, Inc. (November 2008)

Table 5

	Morning Peak			Midday Peak			PM Peak		
	2008	2013 with	2013 without	2008	2013 with	2013 without	2008	2013 with	2013 without
	Existing Conditions (8:00 - 9:00)	Project Scenario (7:20 - 8:20)	Project Scenario (7:30 - 8:30)	Existing Conditions (11:00 - 12:00)	Project Scenario (11:50 - 12:50)	Project Scenario (12:00 - 13:00)	Existing Conditions (17:00 - 18:00)	Project Scenario (16:00 - 17:00)	Project Scenario (16:00 - 17:00)
Originations									
TBIT ¹	121	278	295	1,311	2,036	1,933	429	1,325	1,272
Other	3,521	5,449	5,144	4,665	3,986	3,947	2,200	3,337	3,337
Subtotal	3,642	5,727	5,439	5,976	6,022	5,880	2,629	4,662	4,609
Terminations									
TBIT ¹	456	1,364	1,352	1,088	1,963	1,747	1,437	1,519	1,335
Other	2,072	2,841	3,034	3,759	3,980	3,900	2,578	3,058	3,058
Subtotal	2,528	4,205	4,386	4,847	5,943	5,647	4,015	4,576	4,393
Total									
TBIT ¹	577	1,642	1,647	2,399	3,999	3,681	1,866	2,843	2,607
Other	5,593	8,290	8,178	8,424	7,966	7,847	4,778	6,394	6,394
Subtotal	6,170	9,932	9,825	10,823	11,965	11,528	6,644	9,238	9,001

¹ Includes O&D passengers at West Remote Gates

Sources: Jacobs Consultancy (TBIT terminations)

Los Angeles World Airports (2008 vehicle counts)

Ricondo & Associates, Inc (all other passenger data and projected vehicle trips)

Prepared by: Ricondo & Associates, Inc. (November 2008)

Table 6**Projected Total Vehicle Trips**

	Morning Peak				
	2008 Existing Conditions (8:00 - 9:00)	2013 with Project Scenario (7:20 - 8:20)	2013 without Project Scenario (7:30 - 8:30)	Change in Vehicles	
				2013 with Project vs. 2008	2013 with vs. 2013 without Project
	[A]	[B]	[C]	[B-A]	[B-C]
Total Inbound Vehicles					
TBIT	289	811	817	522	(6)
Other	3,205	4,790	4,686	1,585	105
Subtotal	3,494	5,601	5,502	2,107	99
Total Outbound Vehicles					
TBIT	359	1,043	1,041	685	2
Other	2,693	3,915	3,940	1,222	(25)
Subtotal	3,052	4,958	4,981	1,906	(22)
	Midday Peak				
	2008 Existing Conditions (11:00 - 12:00)	2013 with Project Scenario (11:50 - 12:50)	2013 without Project Scenario (12:00 - 13:00)	Change in Vehicles	
				2013 with Project vs. 2008	2013 with vs. 2013 without Project
	[A]	[B]	[C]	[B-A]	[B-C]
Total Inbound Vehicles					
TBIT	1,062	1,774	1,631	713	143
Other	3,725	3,537	3,483	(188)	54
Subtotal	4,787	5,311	5,115	524	197
Total Outbound Vehicles					
TBIT	1,114	1,918	1,741	804	177
Other	3,884	3,849	3,783	(35)	66
Subtotal	4,998	5,767	5,524	769	243
	PM Peak				
	2008 Existing Conditions (17:00 - 18:00)	2013 with Project Scenario (16:00 - 17:00)	2013 without Project Scenario (16:00 - 17:00)	Change in Vehicles	
				2013 with Project vs. 2008	2013 with vs. 2013 without Project
	[A]	[B]	[C]	[B-A]	[B-C]
Total Inbound Vehicles					
TBIT	991	1,584	1,458	593	125
Other	2,658	3,601	3,601	943	-
Subtotal	3,649	5,185	5,059	1,536	125
Total Outbound Vehicles					
TBIT	1,276	1,746	1,584	470	162
Other	2,942	3,821	3,821	879	-
Subtotal	4,218	5,567	5,405	1,349	162

Sources: Los Angeles World Airports (2008 vehicle counts)

Ricondo & Associates, Inc.

Prepared by: Ricondo & Associates, Inc. (November 2008)

Table 7**Employee Lot D North and Lot E Parking Survey Results**

Employment Center	TBIT Employee Category	AM Peak (8:00 - 9:00)		Midday Peak (11:00 - 12:00)		PM Peak (17:00 - 18:00) ¹	
		Survey Results	% PAX	Survey Results	% PAX	Survey Results	% PAX
Non TBIT		105	40.4%	96	70.6%	47	47.5%
TBIT		155	59.6%	40	29.4%	52	52.5%
			100.0%		100.0%		100.0%
	Airlines	21	13.5%	19	47.5%	28	53.7%
	Concessions	29	18.7%	7	17.5%	3	6.1%
	Security	29	18.6%	8	20.0%	13	25.6%
	Maintenance/Custodial	4	2.9%	1	2.5%	1	1.2%
	Other	72	46.3%	5	12.5%	7	13.4%
Total		155	100.0%	40	100.0%	52	100.0%

¹ Only November 19, 2008 results are available for this time.

Sources: Los Angeles World Airports (Combined November 19, 2008 and December 3, 2008 Employee Parking Surveys)

Ricondo & Associates, Inc.

Prepared by: Ricondo & Associates, Inc. (December 2008)

Table 8

Projected Total Vehicle Trips - Inbound AM Peak

	Morning Peak				
	Total Inbound Vehicles				
	2008 Existing Conditions	2013 with Project Scenario	2013 without Project Scenario	Change in Vehicles	
				2013 with Project vs. 2008	2013 with vs. 2013 without Project
[A]	[B]	[C]	[B-A]	[B-C]	
CTA Traffic					
TBIT	289	811	817	522	(6)
Other	3,205	4,790	4,686	1,585	105
Subtotal	3,494	5,601	5,502	2,107	99
Airport Public Parking ^{1/}					
TBIT	4	10	11	6	(1)
Other	126	195	184	69	11
Subtotal	130	204	194	74	10
Airport Employee Parking ^{1/}					
TBIT	171	329	339	158	(9)
Other	623	638	635	15	3
Subtotal	794	967	973	173	(6)
Rental Car Facility ^{1/}					
TBIT	23	53	56	30	(3)
Other	673	1,041	983	368	58
Subtotal	696	1,094	1,039	398	55
Off-Airport Parking Facilities ^{1/}					
TBIT	6	14	15	8	(1)
Other	183	283	267	100	16
Subtotal	189	297	282	108	15
Total Airport					
TBIT	494	1,218	1,238	724	(20)
Other	4,809	6,947	6,754	2,137	193
Subtotal	5,303	8,164	7,991	2,861	173
Cargo	1,126	1,339	1,339	213	-
Total	6,429	9,504	9,331	3,075	173

Note: ^{1/} Does not include shuttles trips which are included in the CTA traffic volumes. Refer to detail sheet for shuttle actuals and volumes by driveway locations

Sources: Los Angeles World Airports (2008 vehicle counts)
 Ricondo & Associates, Inc.
 Prepared by: Ricondo & Associates, Inc. (November 2008)

Table 9

Projected Total Vehicle Trips - Outbound AM Peak

	Morning Peak				
	Total Outbound Vehicles				
	2008	2013 with	2013 without	Change in Vehicles	
	Existing Conditions	Project Scenario	Project Scenario	2013 with Project vs. 2008	2013 with vs. 2013 without Project
[A]	[B]	[C]	[B-A]	[B-C]	
CTA Traffic					
TBIT	359	1,043	1,041	685	2
Other	2,693	3,915	3,940	1,222	(25)
Subtotal	3,052	4,958	4,981	1,906	(22)
Airport Public Parking ^{1/}					
TBIT	6	19	19	13	0
Other	29	39	42	11	(3)
Subtotal	35	58	61	23	(3)
Airport Employee Parking ^{1/}					
TBIT	51	99	101	47	(3)
Other	327	335	333	8	2
Subtotal	378	433	434	55	(1)
Rental Car Facility ^{1/}					
TBIT	98	293	290	195	3
Other	445	610	652	165	(42)
Subtotal	543	903	942	360	(39)
Off-Airport Parking Facilities ^{1/}					
TBIT	13	39	39	26	0
Other	59	81	86	22	(6)
Subtotal	72	120	125	48	(5)
Total Airport					
TBIT	527	1,493	1,490	966	3
Other	3,553	4,980	5,053	1,427	(73)
Subtotal	4,080	6,473	6,543	2,393	(70)
Cargo	795	946	946	151	-
Total	4,875	7,419	7,489	2,544	(70)

Note: ^{1/} Does not include shuttles trips which are included in the CTA traffic volumes. Refer to detail sheet for shuttle actuals and volumes by driveway locations

Sources: Los Angeles World Airports (2008 vehicle counts)
 Ricondo & Associates, Inc.
 Prepared by: Ricondo & Associates, Inc. (November 2008)

Table 10

Projected Total Vehicle Trips - Inbound Midday Peak

	Midday Peak				
	Total Inbound Vehicles				
	2008	2013 with	2013 without	Change in Vehicles	
	Existing Conditions	Project Scenario	Project Scenario	2013 with Project vs. 2008	2013 with vs. 2013 without Project
	[A]	[B]	[C]	[B-A]	[B-C]
CTA Traffic					
TBIT	1,062	1,774	1,631	713	143
Other	3,725	3,537	3,483	(188)	54
Subtotal	4,787	5,311	5,115	524	197
Airport Public Parking ^{1/}					
TBIT	22	34	32	12	2
Other	77	66	65	(11)	1
Subtotal	99	100	97	1	2
Airport Employee Parking ^{1/}					
TBIT	67	128	132	61	(4)
Other	697	713	710	17	3
Subtotal	764	842	842	78	(0)
Rental Car Facility ^{1/}					
TBIT	185	287	273	102	14
Other	658	562	557	(96)	6
Subtotal	843	850	830	7	20
Off-Airport Parking Facilities ^{1/}					
TBIT	38	58	55	21	3
Other	133	114	113	(19)	1
Subtotal	171	172	168	1	4
Total Airport					
TBIT	1,373	2,282	2,123	909	159
Other	5,291	4,993	4,928	(298)	64
Subtotal	6,664	7,275	7,052	611	223
Cargo	963	1,145	1,145	182	-
Total	7,627	8,420	8,197	793	223

Note: ^{1/} Does not include shuttles trips which are included in the CTA traffic volumes. Refer to detail sheet for shuttle actuals and volumes by driveway locations

Sources: Los Angeles World Airports (2008 vehicle counts)
 Ricondo & Associates, Inc.
 Prepared by: Ricondo & Associates, Inc. (November 2008)

Table 11

Projected Total Vehicle Trips - Outbound Midday Peak

	Midday Peak				
	Total Outbound Vehicles				
	2008	2013 with	2013 without	Change in Vehicles	
	Existing Conditions	Project Scenario	Project Scenario	2013 with Project vs. 2008	2013 with vs. 2013 without Project
[A]	[B]	[C]	[B-A]	[B-C]	
CTA Traffic					
TBIT	1,114	1,918	1,741	804	177
Other	3,884	3,849	3,783	(35)	66
Subtotal	4,998	5,767	5,524	769	243
Airport Public Parking ^{1/}					
TBIT	16	30	26	13	3
Other	57	60	59	3	1
Subtotal	73	89	85	16	4
Airport Employee Parking ^{1/}					
TBIT	36	69	71	33	(2)
Other	581	595	592	14	3
Subtotal	617	664	663	47	1
Rental Car Facility ^{1/}					
TBIT	198	358	319	159	39
Other	686	726	711	40	15
Subtotal	884	1,084	1,030	200	54
Off-Airport Parking Facilities ^{1/}					
TBIT	22	40	36	18	4
Other	77	81	80	5	2
Subtotal	99	121	115	22	6
Total Airport					
TBIT	1,387	2,414	2,192	1,027	222
Other	5,284	5,311	5,225	27	87
Subtotal	6,671	7,725	7,417	1,054	309
Cargo	970	1,154	1,154	184	-
Total	7,641	8,879	8,570	1,238	309

Note: ^{1/} Does not include shuttles trips which are included in the CTA traffic volumes. Refer to detail sheet for shuttle actuals and volumes by driveway locations

Sources: Los Angeles World Airports (2008 vehicle counts)
 Ricondo & Associates, Inc.
 Prepared by: Ricondo & Associates, Inc. (November 2008)

Table 12

Projected Total Vehicle Trips - Inbound PM Peak

		PM Peak				
		Total Inbound Vehicles				
		2008	2013 with	2013 without	Change in Vehicles	
		Existing Conditions	Project Scenario	Project Scenario	2013 with Project vs. 2008	2013 with vs. 2013 without Project
		[A]	[B]	[C]	[B-A]	[B-C]
CTA Traffic						
	TBIT	991	1,584	1,458	593	125
	Other	2,658	3,601	3,601	943	-
	Subtotal	3,649	5,185	5,059	1,536	125
Airport Public Parking ^{1/}						
	TBIT	15	46	45	31	2
	Other	77	117	117	40	-
	Subtotal	92	163	161	71	2
Airport Employee Parking ^{1/}						
	TBIT	117	204	212	87	(8)
	Other	313	321	319	8	2
	Subtotal	430	525	531	95	(6)
Rental Car Facility ^{1/}						
	TBIT	96	298	286	201	12
	Other	495	750	750	255	-
	Subtotal	591	1,048	1,036	457	12
Off-Airport Parking Facilities ^{1/}						
	TBIT	16	51	49	34	2
	Other	85	128	128	44	-
	Subtotal	101	179	177	78	2
Total Airport						
	TBIT	1,235	2,183	2,049	948	133
	Other	3,628	4,917	4,915	1,289	2
	Subtotal	4,863	7,100	6,965	2,237	135
	Cargo	992	1,180	1,180	188	-
	Total	5,855	8,279	8,144	2,424	135

Note: ^{1/} Does not include shuttles trips which are included in the CTA traffic volumes. Refer to detail sheet for shuttle actuals and volumes by driveway locations

Sources: Los Angeles World Airports (2008 vehicle counts)
 Ricondo & Associates, Inc.
 Prepared by: Ricondo & Associates, Inc. (November 2008)

Table 13

Projected Total Vehicle Trips - Outbound PM Peak

		PM Peak				
		Total Outbound Vehicles			Change in Vehicles	
		2008	2013 with	2013 without	2013 with Project vs. 2008	2013 with vs. 2013 without Project
		Existing Conditions	Project Scenario	Project Scenario	2013 with Project vs. 2008	2013 with vs. 2013 without Project
		[A]	[B]	[C]	[B-A]	[B-C]
CTA Traffic						
	TBIT	1,276	1,746	1,584	470	162
	Other	2,942	3,821	3,821	879	-
	Subtotal	4,218	5,567	5,405	1,349	162
Airport Public Parking ^{1/}						
	TBIT	41	43	38	2	5
	Other	73	87	87	14	-
	Subtotal	114	130	125	16	5
Airport Employee Parking ^{1/}						
	TBIT	162	284	295	122	(11)
	Other	551	564	561	13	3
	Subtotal	713	848	856	135	(8)
Rental Car Facility ^{1/}						
	TBIT	189	200	176	11	24
	Other	340	403	403	63	-
	Subtotal	529	603	579	74	24
Off-Airport Parking Facilities ^{1/}						
	TBIT	60	63	56	3	8
	Other	107	127	127	20	-
	Subtotal	167	190	183	23	8
Total Airport						
	TBIT	1,728	2,336	2,148	608	188
	Other	4,013	5,002	4,999	989	3
	Subtotal	5,741	7,339	7,147	1,598	191
	Cargo	1,086	1,292	1,292	206	-
	Total	6,827	8,630	8,439	1,803	191

Note: ^{1/} Does not include shuttles trips which are included in the CTA traffic volumes. Refer to detail sheet for shuttle actuals and volumes by driveway locations

Sources: Los Angeles World Airports (2008 vehicle counts)
 Ricondo & Associates, Inc.
 Prepared by: Ricondo & Associates, Inc. (November 2008)

Appendix C-8
LAX Bradley West Project Draft EIR

HCM Intersection and Freeway Analysis

May 2009

Prepared for:

Los Angeles World Airports
One World Way
Los Angeles, California 90045

Prepared by:

Fehr & Peers Transportation Consultants
201 Santa Monica Boulevard, Suite 500
Santa Monica, CA 90401

Appendix C-8
HCM Intersection Analysis - Existing (2008) Conditions, Future-Adjusted (2013) Without Project Conditions, and Future (2013) With Project Conditions

Int #	Intersection	Existing (2008) Conditions AM		Future-Adjusted (2013) Without Project AM		Future (2013) With Project AM		Existing (2008) Conditions PM		Future-Adjusted (2013) Without Project PM		Future (2013) With Project PM	
		Delay	LOS	Delay	LOS	Delay	LOS	Delay	LOS	Delay	LOS	Delay	LOS
58	Florence Blvd & La Cienega Blvd	42	D	51	D	56	E	64	E	92	F	98	F
73	Imperial Hwy & I-105 WB Off-Ramp	91	F	152	F	151	F	36	D	39	D	39	D
96	I-405 SB Ramps & La Cienega Blvd n/o Century Blvd	17	B	30	C	38	D	14	B	25	C	34	C
97	I-405 SB Ramps & La Cienega Blvd s/o Century Blvd	9	A	9	A	9	A	10	A	10	B	11	B
102	La Tijera Blvd & I-405 NB Ramps	27	C	27	C	27	C	19	B	24	C	24	C
103	La Tijera Blvd & I-405 SB Ramps	22	C	20	B	21	C	73	E	30	C	32	B
139	I-105 WB Off-Ramp & Sepulveda Blvd	107	F	126	F	152	F	81	F	104	F	130	F

Appendix C-8
HCM Freeway Analysis - Existing (2008) Conditions, Future-Adjusted (2013) Without Project Conditions, and Future (2013) With Project Conditions

Freeway	Intersection	Existing (2008) Conditions AM		Future-Adjusted (2013) Without Project AM		Future (2013) With Project AM		Existing (2008) Conditions PM		Future-Adjusted (2013) Without Project PM		Future (2013) With Project PM	
		Delay	LOS	Delay	LOS	Delay	LOS	Delay	LOS	Delay	LOS	Delay	LOS
I-105 WB	Sepulveda Boulevard Off-Ramp	15.6	B	16.4	B	17.0	B	11.5	B	11.5	B	12.1	B
I-405 NB	La Tijera Boulevard On-Ramp	*	F	*	F	*	F	24.9	C	26.2	C	26.5	C
I-405 SB	La Tijera Boulevard Off-Ramp	29.3	D	36.7	E	37.2	E	36.4	E	*	F	*	F

* The density can not be calculated because the demand exceeds the capacity of the mainline or ramp.

Appendix C-9
LAX Bradley West Project Draft EIR

Mitigation Timing

May 2009

Prepared for:

Los Angeles World Airports
One World Way
Los Angeles, California 90045

Prepared by:

Fehr & Peers Transportation Consultants
201 Santa Monica Boulevard, Suite 500
Santa Monica, CA 90401

Appendix C-9

Timing for Implementation of the Mitigation Measures (One MAP) - Future-Adjusted (2013) Without Project Conditions and Future (2013) With Project Conditions

Int #	Intersection	Jurisdiction	ATSAC ¹	ATCS ¹	(2013) Without Project Conditions AM		Future (2013) With Project Conditions AM		Significance		(2013) Without Project Conditions MD		Future (2013) With Project Conditions MD		Significance		(2013) Without Project Conditions PM		Future (2013) With Project Conditions PM		Significance	
					V/C	LOS	V/C	LOS	Delta	Impact?	V/C	LOS	V/C	LOS	Delta	Impact?	V/C	LOS	V/C	LOS	V/C	LOS
9	Aiport Blvd and Manchester Ave	LA	X	X	0.688	B	0.696	B	0.007	NO	0.676	B	0.681	B	0.005	NO	0.961	E	0.965	E	0.004	NO
10	Arbor Vitae St and Aviation Blvd	LA/ Inglewood	X	X	0.555	A	0.563	A	0.008	NO	0.432	A	0.439	A	0.007	NO	0.657	B	0.665	B	0.008	NO
71	Imperial Hwy and Sepulveda Blvd	Caltrans/ El Segundo/ LA	X	X	0.677	B	0.682	B	0.004	NO	0.752	C	0.758	C	0.006	NO	1.011	F	1.016	F	0.004	NO
96	La Cienega Blvd and I-405 SB Ramps n/o Century Blvd	Caltrans/ Inglewood/ LA	X	X	0.654	B	0.661	B	0.007	NO	0.519	A	0.527	A	0.008	NO	0.579	A	0.589	A	0.010	NO
101	La Tijera Blvd and Sepulveda Blvd	LA	X	X	0.569	A	0.586	A	0.017	NO	0.536	A	0.563	A	0.026	NO	0.654	B	0.675	B	0.021	NO
136	Sepulveda Blvd and 76th/77th St	LA	X	X	0.790	C	0.799	C	0.009	NO	0.480	A	0.485	A	0.005	NO	0.627	B	0.632	B	0.005	NO

Appendix C-9

Timing for Implementation of the Mitigation Measures (Two MAP) - Future-Adjusted (2013) Without Project Conditions and Future (2013) With Project Conditions

Int #	Intersection	Jurisdiction	ATSAC ¹	ATCS ¹	(2013) Without Project Conditions AM		Future (2013) With Project Conditions AM		Significance		(2013) Without Project Conditions MD		Future (2013) With Project Conditions MD		Significance		(2013) Without Project Conditions PM		Future (2013) With Project Conditions PM		Significance	
					V/C	LOS	V/C	LOS	Delta	Impact?	V/C	LOS	V/C	LOS	Delta	Impact?	V/C	LOS	V/C	LOS	V/C	LOS
9	Aiport Blvd and Manchester Ave	LA	X	X	0.696	B	0.710	C	0.015	NO	0.679	B	0.689	B	0.010	NO	1.003	F	1.011	F	0.007	NO
10	Arbor Vitae St and Aviation Blvd	LA/ Inglewood	X	X	0.593	A	0.609	B	0.016	NO	0.444	A	0.457	A	0.013	NO	0.697	B	0.713	C	0.016	NO
71	Imperial Hwy and Sepulveda Blvd	Caltrans/ El Segundo/ LA	X	X	0.685	B	0.694	B	0.009	NO	0.825	D	0.836	D	0.011	NO	1.039	F	1.048	F	0.009	NO
96	La Cienega Blvd and I-405 SB Ramps n/o Century Blvd	Caltrans/ Inglewood/ LA	X	X	0.675	B	0.690	B	0.015	NO	0.532	A	0.548	A	0.016	NO	0.607	B	0.627	B	0.020	NO
101	La Tijera Blvd and Sepulveda Blvd	LA	X	X	0.615	B	0.649	B	0.034	NO	0.560	A	0.612	B	0.052	NO	0.683	B	0.725	C	0.042	YES
136	Sepulveda Blvd and 76th/77th St	LA	X	X	0.801	D	0.819	D	0.018	NO	0.492	A	0.501	A	0.009	NO	0.640	B	0.651	B	0.011	NO

Appendix C-9

Timing for Implementation of the Mitigation Measures (Three MAP) - Future-Adjusted (2013) Without Project Conditions and Future (2013) With Project Conditions

Int #	Intersection	Jurisdiction	ATSAC ¹	ATCS ²	(2013) Without Project Conditions AM		Future (2013) With Project Conditions AM		Significance		(2013) Without Project Conditions MD		Future (2013) With Project Conditions MD		Significance		(2013) Without Project Conditions PM		Future (2013) With Project Conditions PM		Significance			
					V/C	LOS	V/C	LOS	Delta	Impact?	V/C	LOS	V/C	LOS	Delta	Impact?	V/C	LOS	V/C	LOS	V/C	LOS	Delta	Impact?
					9	Aiport Blvd and Manchester Ave	LA	X	X	0.703	C	0.725	C	0.022	NO	0.687	B	0.699	B	0.012	NO	1.043	F	1.054
10	Arbor Vitae St and Aviation Blvd	LA/ Inglewood	X	X	0.631	B	0.655	B	0.024	NO	0.455	A	0.475	A	0.020	NO	0.737	C	0.761	C	0.024	NO		
71	Imperial Hwy and Sepulveda Blvd	Caltrans/ El Segundo/ LA	X	X	0.691	B	0.705	C	0.015	NO	0.897	D	0.913	E	0.016	YES	1.065	F	1.079	F	0.014	YES		
96	La Cienega Blvd and I-405 SB Ramps n/o Century Blvd	Caltrans/ Inglewood/ LA	X	X	0.696	B	0.717	C	0.022	NO	0.544	A	0.566	A	0.024	NO	0.636	B	0.667	B	0.031	NO		
101	La Tijera Blvd and Sepulveda Blvd	LA	X	X	0.661	B	0.712	C	0.051	YES	0.584	A	0.663	B	0.079	NO	0.713	C	0.776	C	0.063	YES		
136	Sepulveda Blvd and 76th/77th St	LA	X	X	0.813	D	0.841	D	0.028	YES	0.504	A	0.518	A	0.014	NO	0.661	B	0.676	B	0.015	NO		

**Appendix C-9
Timing for Implementation of the Mitigation Measures (Four MAP) - Future-Adjusted (2013) Without Project Conditions and Future (2013) With Project Conditions**

Int #	Intersection	Jurisdiction	ATSAC ¹	ATCS ²	(2013) Without Project Conditions AM		Future (2013) With Project Conditions AM		Significance		(2013) Without Project Conditions MD		Future (2013) With Project Conditions MD		Significance		(2013) Without Project Conditions PM		Future (2013) With Project Conditions PM		Significance	
					V/C	LOS	V/C	LOS	Delta	Impact?	V/C	LOS	V/C	LOS	Delta	Impact?	V/C	LOS	V/C	LOS	Delta	Impact?
9	Aiport Blvd and Manchester Ave	LA	X	X	0.710	C	0.739	C	0.029	NO	0.695	B	0.707	C	0.012	NO	1.085	F	1.100	F	0.015	YES
10	Arbor Vitae St and Aviation Blvd	LA/ Inglewood	X	X	0.669	B	0.701	C	0.032	NO	0.467	A	0.493	A	0.027	NO	0.777	C	0.809	D	0.032	YES
71	Imperial Hwy and Sepulveda Blvd	Caltrans/ El Segundo/ LA	X	X	0.696	B	0.716	C	0.020	NO	0.968	E	0.989	E	0.022	YES	1.093	F	1.112	F	0.019	YES
96	La Cienega Blvd and I-405 SB Ramps n/o Century Blvd	Caltrans/ Inglewood/ LA	X	X	0.717	C	0.746	C	0.029	NO	0.557	A	0.589	A	0.032	NO	0.664	B	0.705	C	0.041	YES
101	La Tijera Blvd and Sepulveda Blvd	LA	X	X	0.708	C	0.776	C	0.068	YES	0.608	B	0.713	C	0.105	YES	0.742	C	0.826	D	0.084	YES
136	Sepulveda Blvd and 76th/77th St	LA	X	X	0.824	D	0.861	D	0.038	YES	0.515	A	0.534	A	0.019	NO	0.682	B	0.703	C	0.020	NO

CalcaDB

INTERSECTION DATA SUMMARY SHEET

N/S: W/E: I/S No:

AM/PM: Comments:

COUNT DATE: STUDY DATE: GROWTH FACTOR:

Volume/Lane/Signal Configurations

	NORTHBOUND			SOUTHBOUND			WESTBOUND			EASTBOUND		
	LT	TH	RT	LT	TH	RT	LT	TH	RT	LT	TH	RT
EXISTING	252	499	118	59	440	119	64	643	95	81	231	153
AMBIENT												
RELATED												
PROJECT												
TOTAL	252	499	118	59	440	119	64	643	95	81	231	153

LANE: 1 2 1 1 1 1 1 1 1 1 1 1 1

SIGNAL:

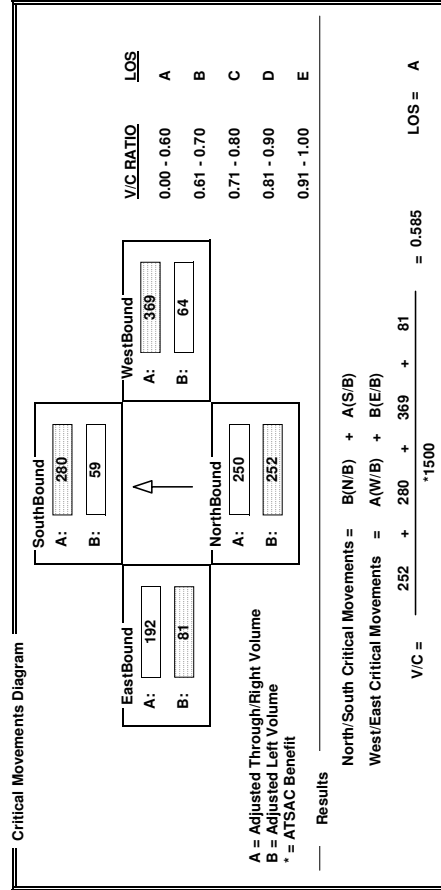

CalcaDB

INTERSECTION DATA SUMMARY SHEET

N/S: W/E: I/S No:

AM/PM: Comments:

COUNT DATE: STUDY DATE: GROWTH FACTOR:

Volume/Lane/Signal Configurations

	NORTHBOUND			SOUTHBOUND			WESTBOUND			EASTBOUND		
	LT	TH	RT	LT	TH	RT	LT	TH	RT	LT	TH	RT
EXISTING	117	564	77	64	697	26	126	1162	204	24	608	58
AMBIENT												
RELATED												
PROJECT												
TOTAL	117	564	77	64	697	26	126	1162	204	24	608	58

LANE: 1 2 1 1 1 1 1 1 1 1 1 1 1

SIGNAL:

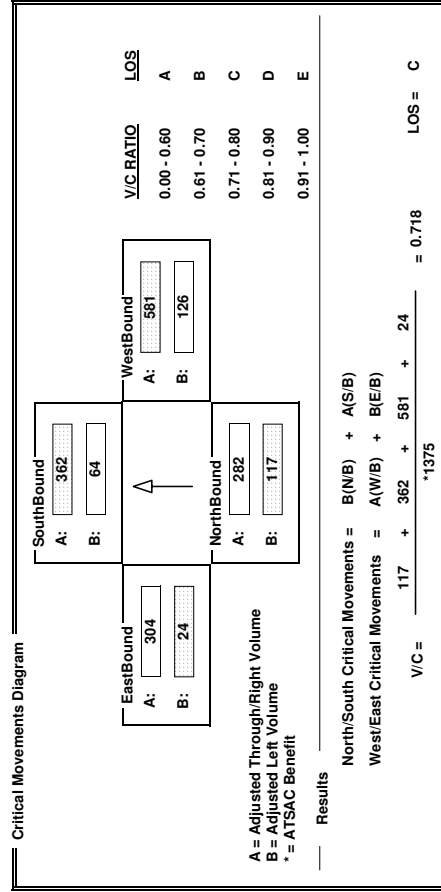

INTERSECTION DATA SUMMARY SHEET

N/S: Sepulveda Blvd W/E: Imperial Hwy I/S No: 71
 AM/PM: AM Comments: MAP 1 Future 2013 w/o Project
 COUNT DATE: STUDY DATE: GROWTH FACTOR:

Volume/Lane/Signal Configurations

	NORTHBOUND			SOUTHBOUND			WESTBOUND			EASTBOUND		
	LT	TH	RT	LT	TH	RT	LT	TH	RT	LT	TH	RT
EXISTING	134	1662	690	274	2066	101	196	326	269	217	270	184
AMBIENT												
RELATED												
PROJECT												
TOTAL	134	1662	690	274	2066	101	196	326	269	217	270	184
LANE	1	3	1	2	3	1	2	2	2	2	3	1
SIGNAL	Prot-Fix Auto			Prot-Fix Auto			Prot-Fix OLA			Prot-Fix Auto		

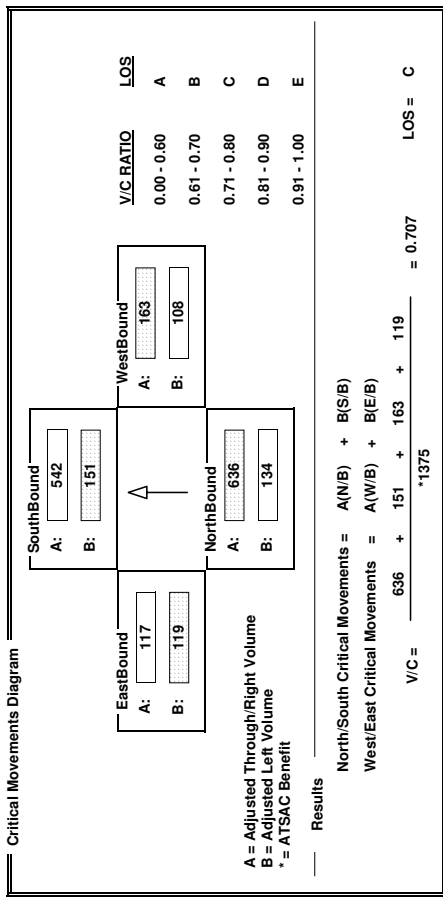

INTERSECTION DATA SUMMARY SHEET

N/S: Sepulveda Blvd W/E: La Tijera Blvd I/S No: 101
 AM/PM: AM Comments: MAP 1 Future 2013 w/o Project
 COUNT DATE: STUDY DATE: GROWTH FACTOR:

Volume/Lane/Signal Configurations

	NORTHBOUND			SOUTHBOUND			WESTBOUND			EASTBOUND		
	LT	TH	RT	LT	TH	RT	LT	TH	RT	LT	TH	RT
EXISTING	97	1370	111	50	1083	55	256	194	34	44	314	78
AMBIENT												
RELATED												
PROJECT												
TOTAL	97	1370	111	50	1083	55	256	194	34	44	314	78
LANE	1	3	1	1	3	1	1	2	1	1	2	1
SIGNAL	Prot-Fix OLA			Prot-Fix OLA			Perm Auto			Prot-Fix OLA		

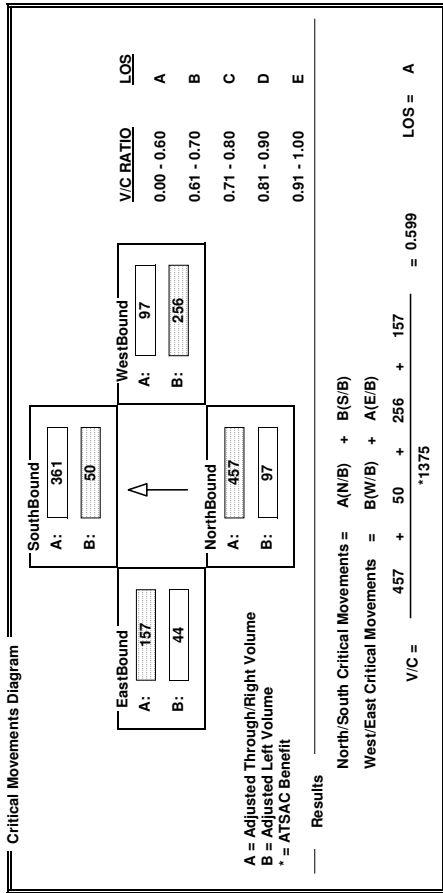

CalcaDB

INTERSECTION DATA SUMMARY SHEET

N/S: W/E: I/S No:

AM/PM: Comments:

COUNT DATE: STUDY DATE: GROWTH FACTOR:

Volume/Lane/Signal Configurations												
	NORTHBOUND			SOUTHBOUND			WESTBOUND			EASTBOUND		
	LT	TH	RT	LT	TH	RT	LT	TH	RT	LT	TH	RT
EXISTING	0	882	115	159	422	0	809	0	65	0	0	0
AMBIENT												
RELATED												
PROJECT												
TOTAL	0	882	115	159	422	0	809	0	65	0	0	0
LANE	1	1	1	1	2	1	1	1	1	1	1	1
SIGNAL	Phasing	RTOR	OLA	Phasing	RTOR	Prot-Fix	Phasing	RTOR	Split	Auto	Phasing	RTOR
	Perm	Auto	Auto	Perm	Auto	Auto	Perm	Auto	Split	Auto	Perm	Auto

Critical Movements Diagram

SouthBound A: 211 B: 159

WestBound A: 437 B: 437

EastBound A: 0 B: 0

NorthBound A: 441 B: 0

A = Adjusted Through/Right Volume
B = Adjusted Left Volume
* = ATSSAC Benefit

Results

North/South Critical Movements = A(N/B) + B(S/B)
West/East Critical Movements = A(W/B) + A(E/B)

V/C = $\frac{441 + 159 + 437 + 0}{1375} = 0.684$ LOS = B

CalcaDB

INTERSECTION DATA SUMMARY SHEET

N/S: W/E: I/S No:

AM/PM: Comments:

COUNT DATE: STUDY DATE: GROWTH FACTOR:

Volume/Lane/Signal Configurations												
	NORTHBOUND			SOUTHBOUND			WESTBOUND			EASTBOUND		
	LT	TH	RT	LT	TH	RT	LT	TH	RT	LT	TH	RT
EXISTING	40	1938	13	54	1188	136	27	78	242	592	40	52
AMBIENT												
RELATED												
PROJECT												
TOTAL	40	1938	13	54	1188	136	27	78	242	592	40	52
LANE	1	3	1	1	2	1	1	1	1	2	1	1
SIGNAL	Phasing	RTOR	Auto	Phasing	RTOR	Perm	Phasing	RTOR	Split	Auto	Phasing	RTOR
	Perm	Auto	Auto	Perm	Auto	Auto	Perm	Auto	Split	Auto	Perm	Auto

Critical Movements Diagram

SouthBound A: 441 B: 54

WestBound A: 242 B: 27

EastBound A: 52 B: 326

NorthBound A: 646 B: 40

A = Adjusted Through/Right Volume
B = Adjusted Left Volume
* = ATSSAC Benefit

Results

North/South Critical Movements = A(N/B) + B(S/B)
West/East Critical Movements = A(W/B) + B(E/B)

V/C = $\frac{646 + 54 + 242 + 326}{1425} = 0.820$ LOS = D

CalcaDB

INTERSECTION DATA SUMMARY SHEET

N/S: W/E: I/S No:

AM/PM: Comments:

COUNT DATE: STUDY DATE: GROWTH FACTOR:

Volume/Lane/Signal Configurations

	NORTHBOUND			SOUTHBOUND			WESTBOUND			EASTBOUND		
	LT	TH	RT	LT	TH	RT	LT	TH	RT	LT	TH	RT
EXISTING	106	698	228	66	572	25	129	830	57	21	1045	63
AMBIENT												
RELATED												
PROJECT												
TOTAL	106	698	228	66	572	25	129	830	57	21	1045	63
LANE	1	2	1	1	1	1	1	2	1	1	2	1
SIGNAL	Prot-Fix			Auto			Prot-Fix			Auto		

Critical Movements Diagram

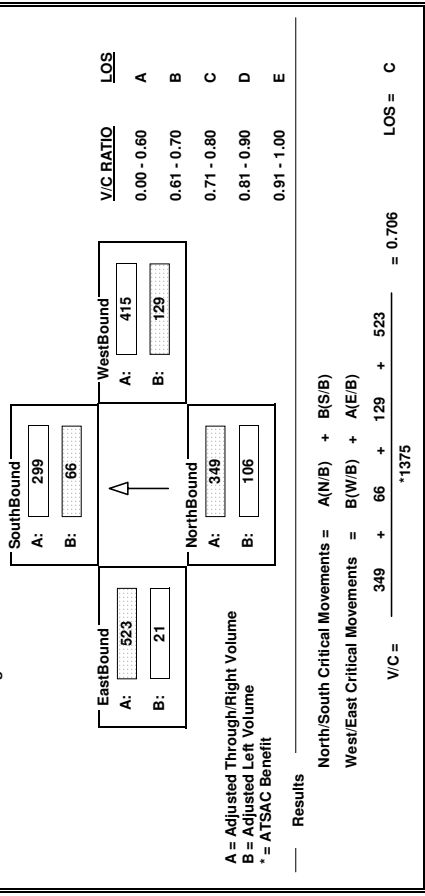

CalcaDB

INTERSECTION DATA SUMMARY SHEET

N/S: W/E: I/S No:

AM/PM: Comments:

COUNT DATE: STUDY DATE: GROWTH FACTOR:

Volume/Lane/Signal Configurations

	NORTHBOUND			SOUTHBOUND			WESTBOUND			EASTBOUND		
	LT	TH	RT	LT	TH	RT	LT	TH	RT	LT	TH	RT
EXISTING	223	398	118	110	318	118	89	429	54	94	368	168
AMBIENT												
RELATED												
PROJECT												
TOTAL	223	398	118	110	318	118	89	429	54	94	368	168
LANE	1	2	1	1	1	1	1	1	1	1	1	1
SIGNAL	Perm			Auto			Perm			Auto		

Critical Movements Diagram

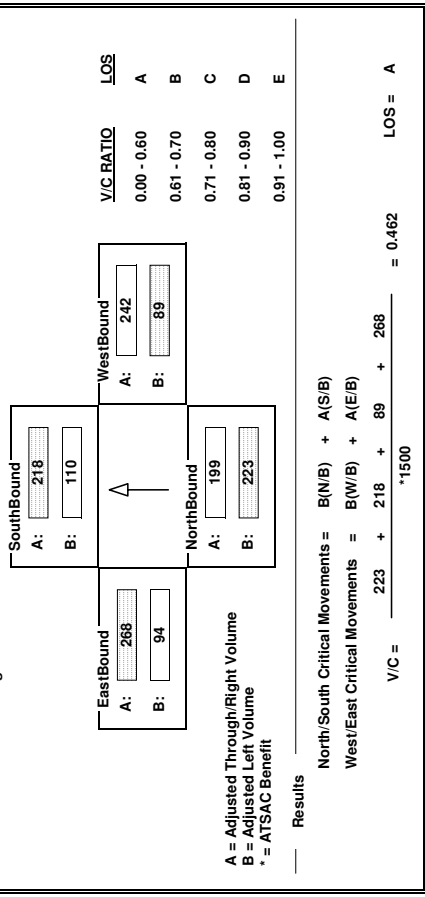

CalcaDB

INTERSECTION DATA SUMMARY SHEET

N/S: Sepulveda Blvd W/E: Imperial Hwy I/S No: 71
 AM/PM: **MD** Comments: MAP 1 Future 2013 w/o Project
 COUNT DATE: STUDY DATE: GROWTH FACTOR:

Volume/Lane/Signal Configurations

	NORTHBOUND			SOUTHBOUND			WESTBOUND			EASTBOUND		
	LT	TH	RT	LT	TH	RT	LT	TH	RT	LT	TH	RT
EXISTING	164	1278	773	317	1647	57	184	298	265	231	279	152
AMBIENT												
RELATED												
PROJECT												
TOTAL	164	1278	773	317	1647	57	184	298	265	231	279	152

LANE: 1 3 1 2 3 1 2 2 3 1 2 3 1

SIGNAL: Prot-Fix RTOR Auto Phasing RTOR Auto Prot-Fix OLA Phasing RTOR Auto Prot-Fix Auto

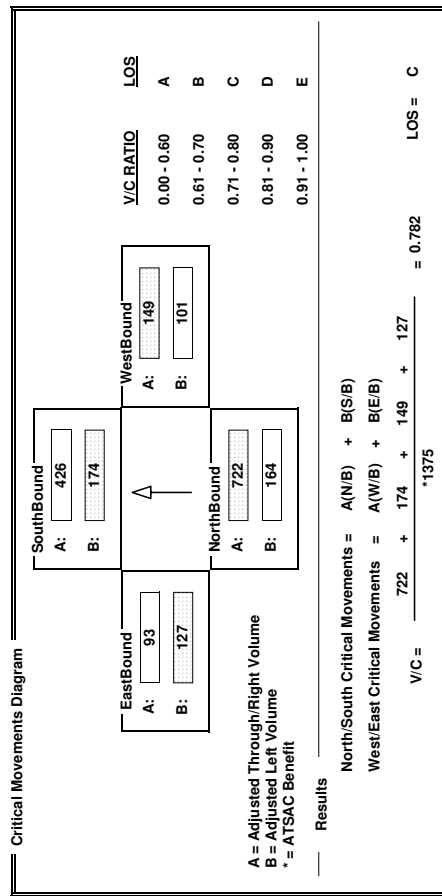

CalcaDB

INTERSECTION DATA SUMMARY SHEET

N/S: Sepulveda Blvd W/E: La Tijera Blvd I/S No: 101
 AM/PM: **MD** Comments: MAP 1 Future 2013 w/o Project
 COUNT DATE: STUDY DATE: GROWTH FACTOR:

Volume/Lane/Signal Configurations

	NORTHBOUND			SOUTHBOUND			WESTBOUND			EASTBOUND		
	LT	TH	RT	LT	TH	RT	LT	TH	RT	LT	TH	RT
EXISTING	105	1187	216	81	1110	48	269	212	79	78	258	68
AMBIENT												
RELATED												
PROJECT												
TOTAL	105	1187	216	81	1110	48	269	212	79	78	258	68

LANE: 1 3 1 1 2 1 1 2 1 2 1 1

SIGNAL: Prot-Fix OLA RTOR OLA Phasing RTOR Auto Prot-Fix OLA

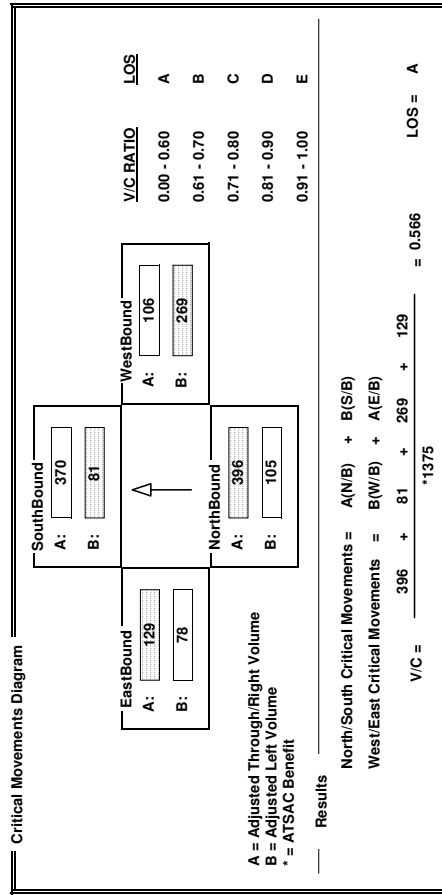

CalcaDB

INTERSECTION DATA SUMMARY SHEET

N/S: W/E: I/S No:
 AM/PM: Comments:
 COUNT DATE: STUDY DATE: GROWTH FACTOR:

Volume/Lane/Signal Configurations

	NORTHBOUND			SOUTHBOUND			WESTBOUND			EASTBOUND		
	LT	TH	RT	LT	TH	RT	LT	TH	RT	LT	TH	RT
EXISTING	51	1435	34	78	1465	206	33	57	80	253	44	56
AMBIENT												
RELATED												
PROJECT												
TOTAL	51	1435	34	78	1465	206	33	57	80	253	44	56
LANE	1	3	1	1	2	1	1	1	1	2	1	1
SIGNAL	Phasing	RTOR	Auto	Phasing	RTOR	Perm	Auto	Phasing	RTOR	Auto	Split	Auto

Critical Movements Diagram

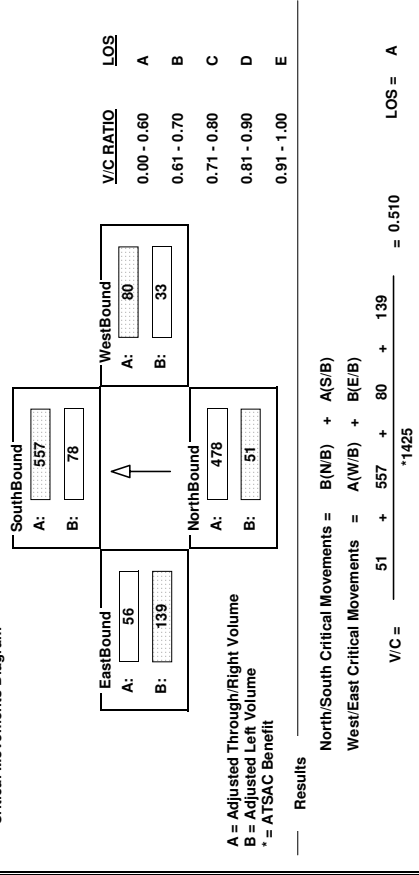

CalcaDB

INTERSECTION DATA SUMMARY SHEET

N/S: W/E: I/S No:
 AM/PM: Comments:
 COUNT DATE: STUDY DATE: GROWTH FACTOR:

Volume/Lane/Signal Configurations

	NORTHBOUND			SOUTHBOUND			WESTBOUND			EASTBOUND		
	LT	TH	RT	LT	TH	RT	LT	TH	RT	LT	TH	RT
EXISTING	0	503	142	142	598	0	842	0	72	0	0	0
AMBIENT												
RELATED												
PROJECT												
TOTAL	0	503	142	142	598	0	842	0	72	0	0	0
LANE	1	1	1	1	2	1	1	1	1	1	1	1
SIGNAL	Phasing	RTOR	OLA	Phasing	RTOR	Auto	Phasing	RTOR	Auto	Split	Auto	Auto

Critical Movements Diagram

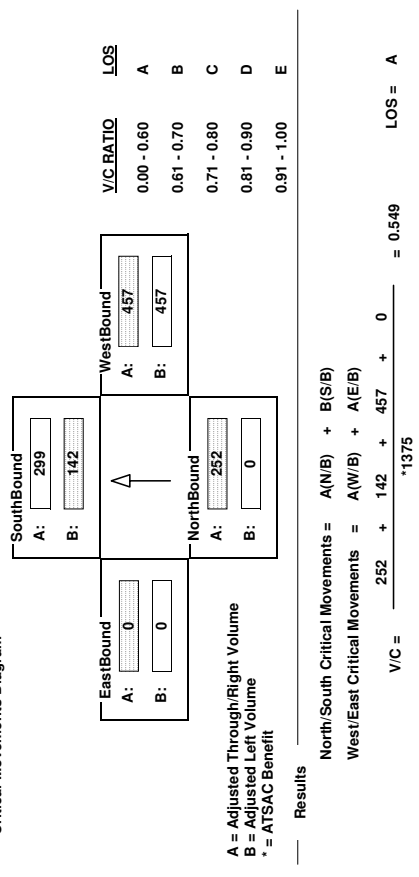

CalcaDB

INTERSECTION DATA SUMMARY SHEET

N/S: W/E: I/S No:

AM/PM: **PM** Comments:

COUNT DATE: STUDY DATE: GROWTH FACTOR:

Volume/Lane/Signal Configurations

	NORTHBOUND			SOUTHBOUND			WESTBOUND			EASTBOUND		
	LT	TH	RT	LT	TH	RT	LT	TH	RT	LT	TH	RT
EXISTING	188	734	284	262	328	125	203	844	166	119	1254	203
AMBIENT												
RELATED												
PROJECT												
TOTAL	188	734	284	262	328	125	203	844	166	119	1254	203
LANE	1	2	1	1	1	1	1	2	1	1	2	1
SIGNAL	Prot-Fix			Auto			Prot-Fix			Auto		
	Phasing			RTOR			Phasing			RTOR		

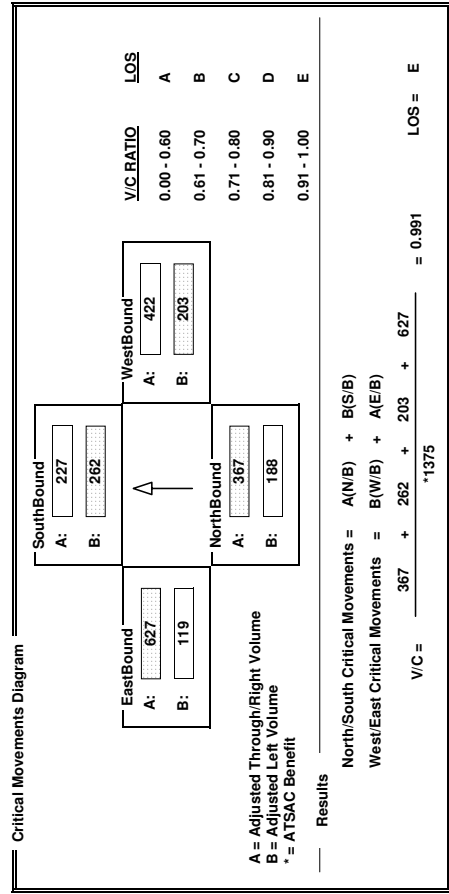

CalcaDB

INTERSECTION DATA SUMMARY SHEET

N/S: W/E: I/S No:

AM/PM: **PM** Comments:

COUNT DATE: STUDY DATE: GROWTH FACTOR:

Volume/Lane/Signal Configurations

	NORTHBOUND			SOUTHBOUND			WESTBOUND			EASTBOUND		
	LT	TH	RT	LT	TH	RT	LT	TH	RT	LT	TH	RT
EXISTING	218	626	124	79	412	92	91	406	53	131	834	316
AMBIENT												
RELATED												
PROJECT												
TOTAL	218	626	124	79	412	92	91	406	53	131	834	316
LANE	1	2	1	1	1	1	1	1	1	1	1	1
SIGNAL	Perm			Auto			Perm			Auto		
	Phasing			RTOR			Phasing			RTOR		

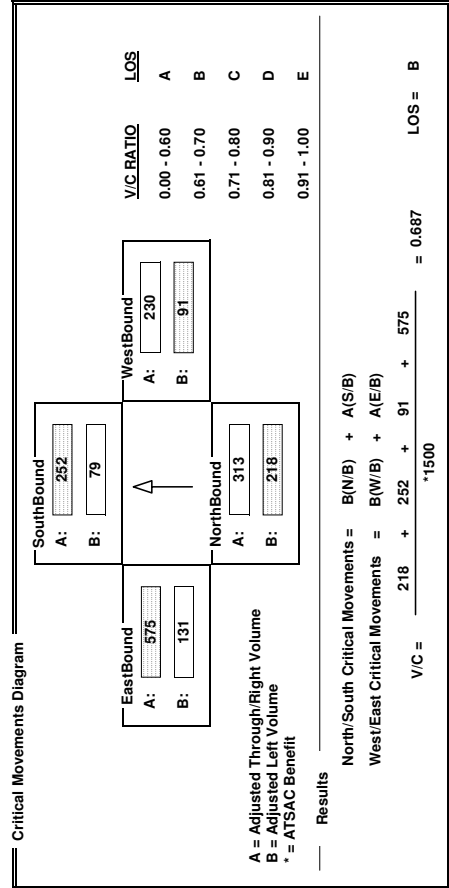

CalcaDB

INTERSECTION DATA SUMMARY SHEET

N/S: Sepulveda Blvd W/E: Imperial Hwy I/S No: 71
 AM/PM: **PM** Comments: MAP 1 Future 2013 w/o Project
 COUNT DATE: STUDY DATE: GROWTH FACTOR:

Volume/Lane/Signal Configurations

	NORTHBOUND			SOUTHBOUND			WESTBOUND			EASTBOUND		
	LT	TH	RT	LT	TH	RT	LT	TH	RT	LT	TH	RT
EXISTING	174	1585	1164	330	2237	80	235	314	337	164	295	165
AMBIENT												
RELATED												
PROJECT												
TOTAL	174	1585	1164	330	2237	80	235	314	337	164	295	165
LANE	1	3	1	2	3	1	2	2	2	2	3	1
SIGNAL	Prot-Fix Auto			Prot-Fix Auto			Prot-Fix OLA			Prot-Fix Auto		

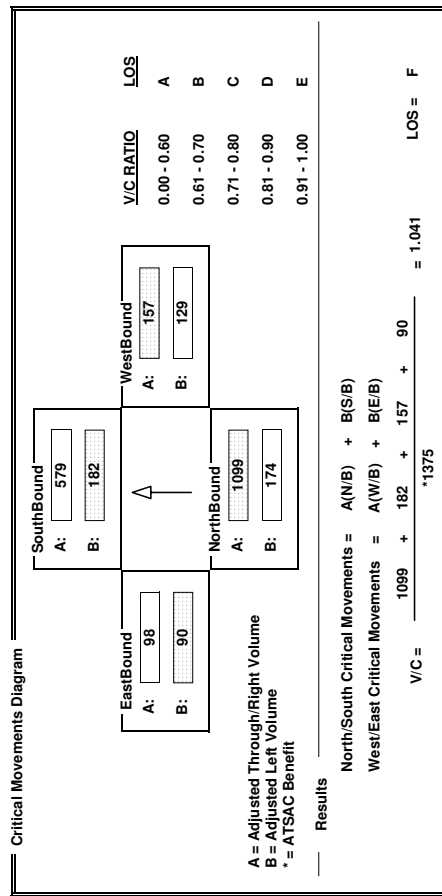

CalcaDB

INTERSECTION DATA SUMMARY SHEET

N/S: Sepulveda Blvd W/E: La Tijera Blvd I/S No: 101
 AM/PM: **PM** Comments: MAP 1 Future 2013 w/o Project
 COUNT DATE: STUDY DATE: GROWTH FACTOR:

Volume/Lane/Signal Configurations

	NORTHBOUND			SOUTHBOUND			WESTBOUND			EASTBOUND		
	LT	TH	RT	LT	TH	RT	LT	TH	RT	LT	TH	RT
EXISTING	152	1536	156	73	1192	81	231	384	58	88	442	76
AMBIENT												
RELATED												
PROJECT												
TOTAL	152	1536	156	73	1192	81	231	384	58	88	442	76
LANE	1	3	1	1	3	1	1	2	1	1	2	1
SIGNAL	Prot-Fix OLA			Prot-Fix OLA			Perm Auto			Prot-Fix OLA		

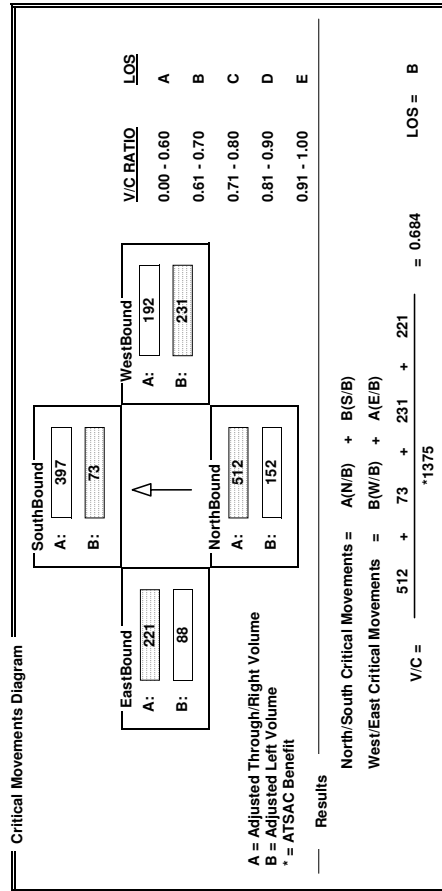

CalcaDB

INTERSECTION DATA SUMMARY SHEET

N/S: W/E: I/S No:

AM/PM: Comments:

COUNT DATE: STUDY DATE: GROWTH FACTOR:

Volume/Lane/Signal Configurations

	NORTHBOUND			SOUTHBOUND			WESTBOUND			EASTBOUND		
	LT	TH	RT	LT	TH	RT	LT	TH	RT	LT	TH	RT
EXISTING	0	606	81	196	781	0	700	0	167	0	0	0
AMBIENT												
RELATED												
PROJECT												
TOTAL	0	606	81	196	781	0	700	0	167	0	0	0

LANE: 1 1 1 1 1 2 1 1 1 1 1 1 1

SIGNAL: Perm OLA RTOR Phasing RTOR Split Auto

Critical Movements Diagram

EastBound: A: 0, B: 0, V/C RATIO: 0.00 - 0.60, LOS: A

SouthBound: A: 391, B: 196, V/C RATIO: 0.61 - 0.70, LOS: B

WestBound: A: 434, B: 434, V/C RATIO: 0.71 - 0.80, LOS: C

NorthBound: A: 303, B: 0, V/C RATIO: 0.81 - 0.90, LOS: D

Results: North/South Critical Movements = A(N/B) + B(S/B) = 303 + 196 + 434 + 0 = 0.609, LOS = B

West/East Critical Movements = A(W/B) + A(E/B) = 434 + 434 + 0 = 0.609, LOS = B

V/C = 0.609, LOS = B

A = Adjusted Through/Right Volume
B = Adjusted Left Volume
* = ATSSAC Benefit

CalcaDB

INTERSECTION DATA SUMMARY SHEET

N/S: W/E: I/S No:

AM/PM: Comments:

COUNT DATE: STUDY DATE: GROWTH FACTOR:

Volume/Lane/Signal Configurations

	NORTHBOUND			SOUTHBOUND			WESTBOUND			EASTBOUND		
	LT	TH	RT	LT	TH	RT	LT	TH	RT	LT	TH	RT
EXISTING	44	1826	28	123	1998	344	36	74	86	227	68	68
AMBIENT												
RELATED												
PROJECT												
TOTAL	44	1826	28	123	1998	344	36	74	86	227	68	68

LANE: 1 3 1 1 1 2 1 1 1 1 1 1 1

SIGNAL: Perm RTOR Phasing RTOR Split Auto

Critical Movements Diagram

EastBound: A: 68, B: 125, V/C RATIO: 0.00 - 0.60, LOS: A

SouthBound: A: 781, B: 123, V/C RATIO: 0.61 - 0.70, LOS: B

WestBound: A: 86, B: 36, V/C RATIO: 0.71 - 0.80, LOS: C

NorthBound: A: 609, B: 44, V/C RATIO: 0.81 - 0.90, LOS: D

Results: North/South Critical Movements = B(N/B) + A(S/B) = 123 + 36 = 0.657, LOS = B

West/East Critical Movements = A(W/B) + B(E/B) = 86 + 44 = 0.657, LOS = B

V/C = 0.657, LOS = B

A = Adjusted Through/Right Volume
B = Adjusted Left Volume
* = ATSSAC Benefit

CalcaDB

INTERSECTION DATA SUMMARY SHEET

N/S: W/E: I/S No:

AM/PM: Comments:

COUNT DATE: STUDY DATE: GROWTH FACTOR:

Volume/Lane/Signal Configurations

	NORTHBOUND			SOUTHBOUND			WESTBOUND			EASTBOUND		
	LT	TH	RT	LT	TH	RT	LT	TH	RT	LT	TH	RT
EXISTING	117	578	79	66	705	26	128	1174	204	24	608	64
AMBIENT												
RELATED												
PROJECT												
TOTAL	117	578	79	66	705	26	128	1174	204	24	608	64

LANE: 1 2 1 1 1 1 1 1 2 1 1 2 1

SIGNAL: Prot-Fix RTOR Phasing RTOR Prot-Fix RTOR Prot-Fix RTOR

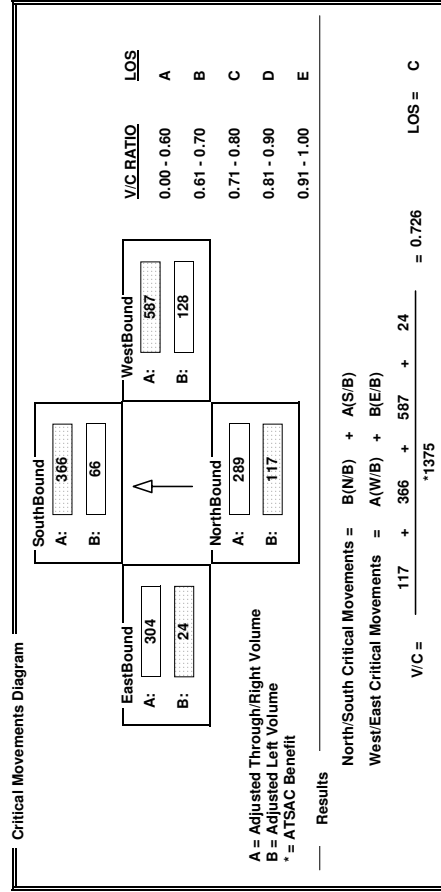

CalcaDB

INTERSECTION DATA SUMMARY SHEET

N/S: W/E: I/S No:

AM/PM: Comments:

COUNT DATE: STUDY DATE: GROWTH FACTOR:

Volume/Lane/Signal Configurations

	NORTHBOUND			SOUTHBOUND			WESTBOUND			EASTBOUND		
	LT	TH	RT	LT	TH	RT	LT	TH	RT	LT	TH	RT
EXISTING	252	511	118	59	442	121	64	659	95	83	237	153
AMBIENT												
RELATED												
PROJECT												
TOTAL	252	511	118	59	442	121	64	659	95	83	237	153

LANE: 1 2 1 1 1 1 1 1 1 1 1 1 1

SIGNAL: Perm RTOR Phasing RTOR Perm RTOR Perm RTOR

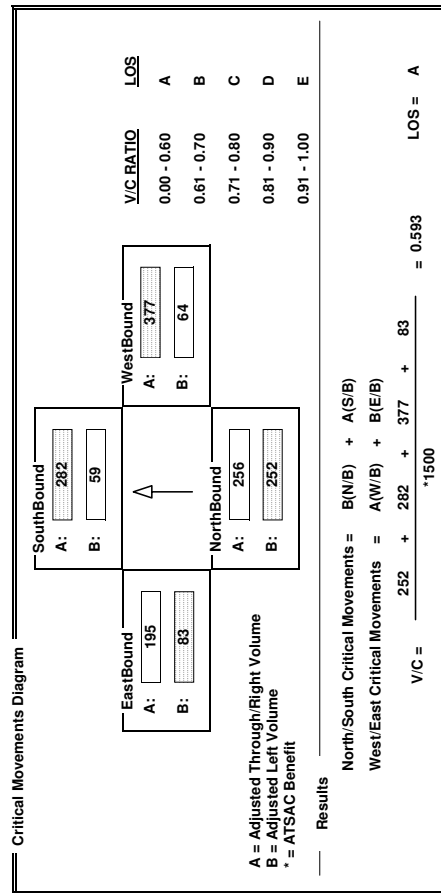

CalcaDB

INTERSECTION DATA SUMMARY SHEET

N/S: W/E: I/S No:
 AM/PM: Comments:
 COUNT DATE: STUDY DATE: GROWTH FACTOR:

Volume/Lane/Signal Configurations

	NORTHBOUND			SOUTHBOUND			WESTBOUND			EASTBOUND		
	LT	TH	RT	LT	TH	RT	LT	TH	RT	LT	TH	RT
EXISTING	134	1680	690	284	2076	101	196	326	277	219	272	184
AMBIENT												
RELATED												
PROJECT												
TOTAL	134	1680	690	284	2076	101	196	326	277	219	272	184

LANE:

Phasing: RTOR RTOR RTOR RTOR RTOR RTOR RTOR RTOR RTOR RTOR RTOR RTOR RTOR
 SIGNAL:

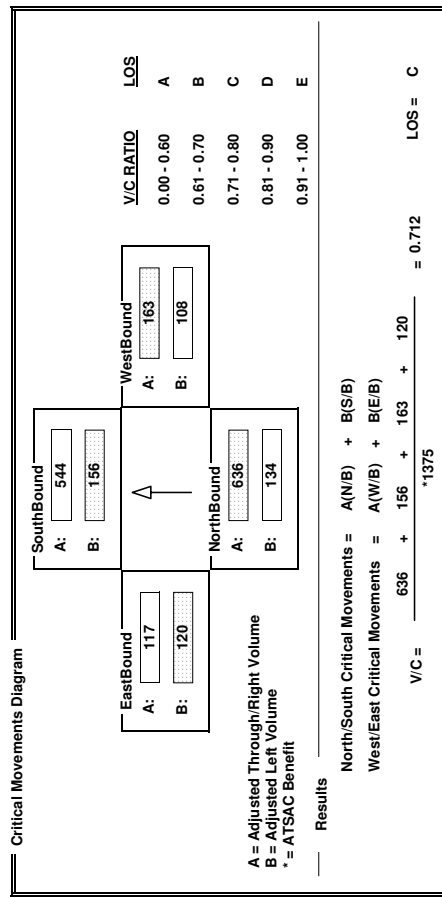

CalcaDB

INTERSECTION DATA SUMMARY SHEET

N/S: W/E: I/S No:
 AM/PM: Comments:
 COUNT DATE: STUDY DATE: GROWTH FACTOR:

Volume/Lane/Signal Configurations

	NORTHBOUND			SOUTHBOUND			WESTBOUND			EASTBOUND		
	LT	TH	RT	LT	TH	RT	LT	TH	RT	LT	TH	RT
EXISTING	97	1410	115	50	1119	55	266	194	34	44	314	78
AMBIENT												
RELATED												
PROJECT												
TOTAL	97	1410	115	50	1119	55	266	194	34	44	314	78

LANE:

Phasing: RTOR RTOR RTOR RTOR RTOR RTOR RTOR RTOR RTOR RTOR RTOR RTOR RTOR
 SIGNAL:

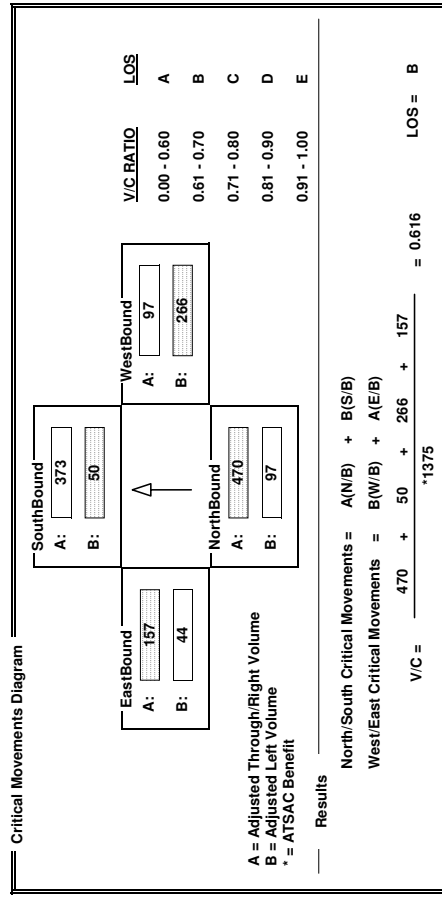

CalcaDB

INTERSECTION DATA SUMMARY SHEET

N/S: W/E: I/S No:
 AM/PM: Comments:
 COUNT DATE: STUDY DATE: GROWTH FACTOR:

Volume/Lane/Signal Configurations

	NORTHBOUND			SOUTHBOUND			WESTBOUND			EASTBOUND		
	LT	TH	RT	LT	TH	RT	LT	TH	RT	LT	TH	RT
EXISTING	40	1978	13	54	1204	136	27	78	242	592	40	52
AMBIENT												
RELATED												
PROJECT												
TOTAL	40	1978	13	54	1204	136	27	78	242	592	40	52

LANE: 1 3 1 1 1 2 1 1 1 1 1 1 1

SIGNAL: Phasing RTOR Auto Auto Auto

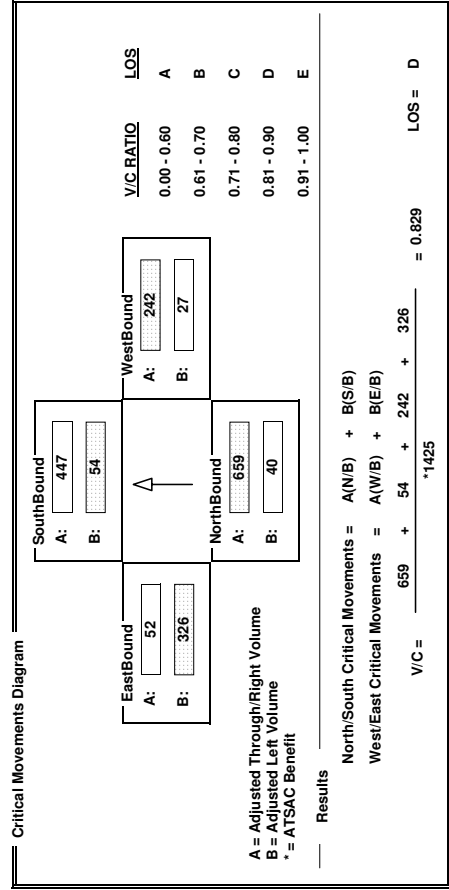

CalcaDB

INTERSECTION DATA SUMMARY SHEET

N/S: W/E: I/S No:
 AM/PM: Comments:
 COUNT DATE: STUDY DATE: GROWTH FACTOR:

Volume/Lane/Signal Configurations

	NORTHBOUND			SOUTHBOUND			WESTBOUND			EASTBOUND		
	LT	TH	RT	LT	TH	RT	LT	TH	RT	LT	TH	RT
EXISTING	0	890	115	159	428	0	819	0	67	0	0	0
AMBIENT												
RELATED												
PROJECT												
TOTAL	0	890	115	159	428	0	819	0	67	0	0	0

LANE: 1 1 1 1 1 2 1 1 1 1 1 1 1

SIGNAL: Phasing RTOR Auto Auto Auto

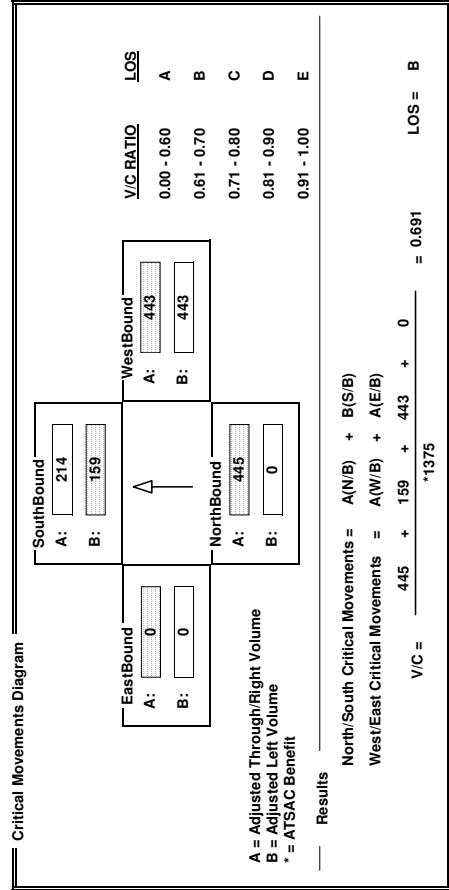

CalcaDB

INTERSECTION DATA SUMMARY SHEET

N/S: W/E: I/S No:

AM/PM: Comments:

COUNT DATE: STUDY DATE: GROWTH FACTOR:

Volume/Lane/Signal Configurations

	NORTHBOUND			SOUTHBOUND			WESTBOUND			EASTBOUND		
	LT	TH	RT	LT	TH	RT	LT	TH	RT	LT	TH	RT
EXISTING	106	712	228	66	580	25	129	838	57	21	1045	67
AMBIENT												
RELATED												
PROJECT												
TOTAL	106	712	228	66	580	25	129	838	57	21	1045	67

LANE: 1 2 1 1 1 1 1 1 1 1 2 1 1

Signal Configurations: Phasing RTOR Prot-Fix Auto Prot-Fix Auto Prot-Fix Auto

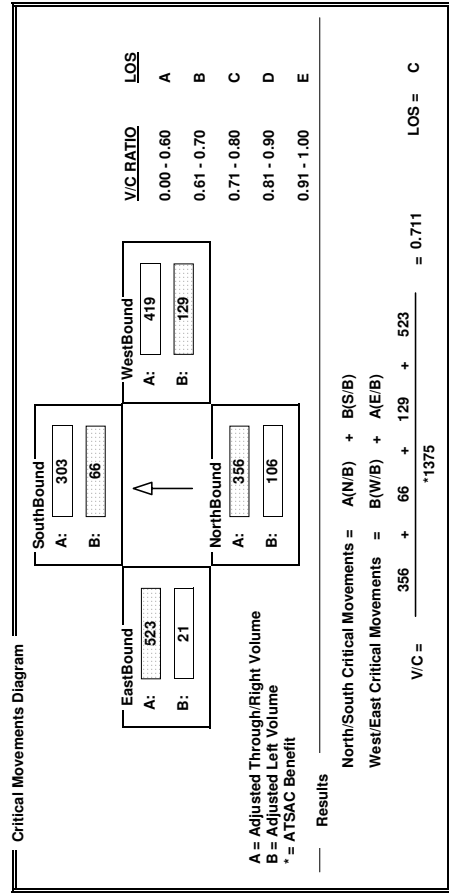

Developed by Chun Wong, 12/04

CalcaDB

INTERSECTION DATA SUMMARY SHEET

N/S: W/E: I/S No:

AM/PM: Comments:

COUNT DATE: STUDY DATE: GROWTH FACTOR:

Volume/Lane/Signal Configurations

	NORTHBOUND			SOUTHBOUND			WESTBOUND			EASTBOUND		
	LT	TH	RT	LT	TH	RT	LT	TH	RT	LT	TH	RT
EXISTING	227	400	118	110	320	122	89	435	54	94	374	168
AMBIENT												
RELATED												
PROJECT												
TOTAL	227	400	118	110	320	122	89	435	54	94	374	168

LANE: 1 2 1 1 1 1 1 1 1 1 1 1 1

Signal Configurations: Phasing RTOR Prot-Fix Auto Perm Auto Perm Auto

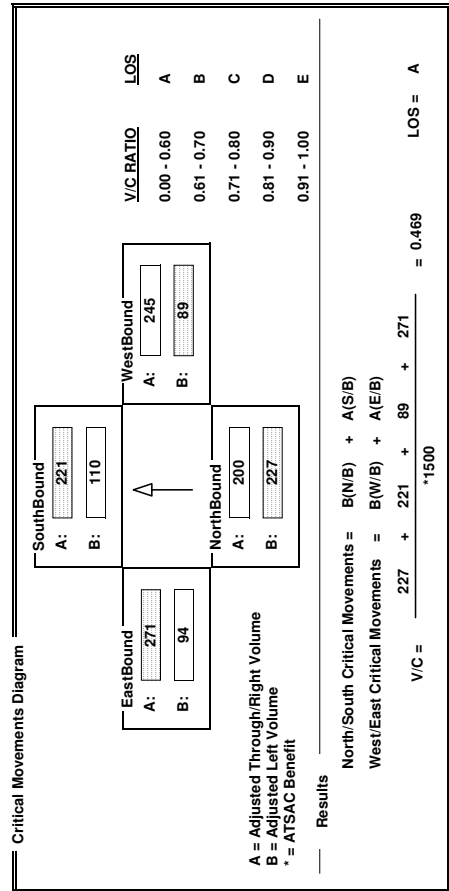

Developed by Chun Wong, 12/04

CalcaDB

INTERSECTION DATA SUMMARY SHEET

N/S: W/E: I/S No:
 AM/PM: Comments:
 COUNT DATE: STUDY DATE: GROWTH FACTOR:

Volume/Lane/Signal Configurations

	NORTHBOUND			SOUTHBOUND			WESTBOUND			EASTBOUND		
	LT	TH	RT	LT	TH	RT	LT	TH	RT	LT	TH	RT
EXISTING	164	1306	775	325	1657	59	184	300	277	231	279	154
AMBIENT												
RELATED												
PROJECT												
TOTAL	164	1306	775	325	1657	59	184	300	277	231	279	154

LANE:

Signal:

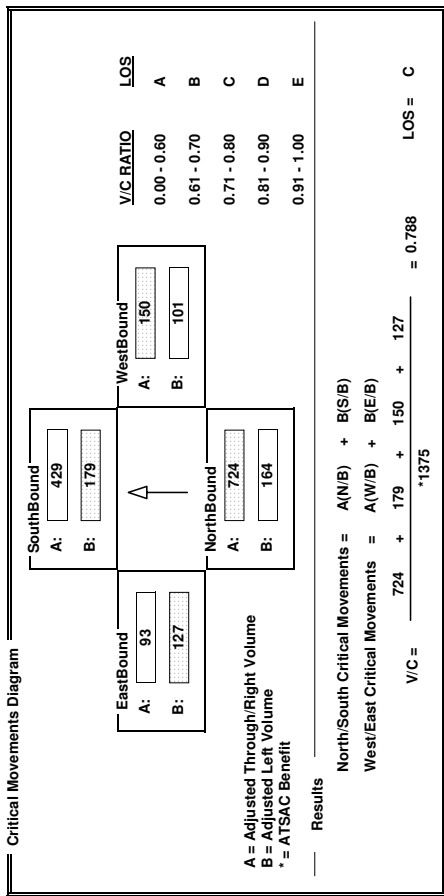

CalcaDB

INTERSECTION DATA SUMMARY SHEET

N/S: W/E: I/S No:
 AM/PM: Comments:
 COUNT DATE: STUDY DATE: GROWTH FACTOR:

Volume/Lane/Signal Configurations

	NORTHBOUND			SOUTHBOUND			WESTBOUND			EASTBOUND		
	LT	TH	RT	LT	TH	RT	LT	TH	RT	LT	TH	RT
EXISTING	105	1211	222	81	1136	48	297	212	79	78	258	68
AMBIENT												
RELATED												
PROJECT												
TOTAL	105	1211	222	81	1136	48	297	212	79	78	258	68

LANE:

Signal:

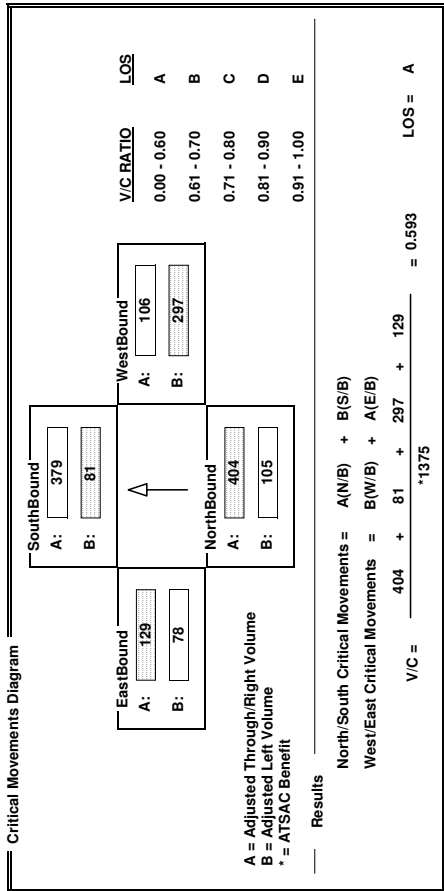

CalcaDB

INTERSECTION DATA SUMMARY SHEET

N/S: W/E: I/S No:
 AM/PM: Comments:
 COUNT DATE: STUDY DATE: GROWTH FACTOR:

Volume/Lane/Signal Configurations

	NORTHBOUND			SOUTHBOUND			WESTBOUND			EASTBOUND		
	LT	TH	RT	LT	TH	RT	LT	TH	RT	LT	TH	RT
EXISTING	51	1455	34	78	1485	206	33	57	80	253	44	56
AMBIENT												
RELATED												
PROJECT												
TOTAL	51	1455	34	78	1485	206	33	57	80	253	44	56

LANE	1	2	3	1	2	1	0	1	1	1	1	1
PHASING	↓	↓	↓	↓	↓	↓	↓	↓	↓	↓	↓	↓
SIGNAL	Perm	Auto	Auto	Perm	Auto	Auto	Auto	Split	Auto	Auto	Split	Auto

Critical Movements Diagram

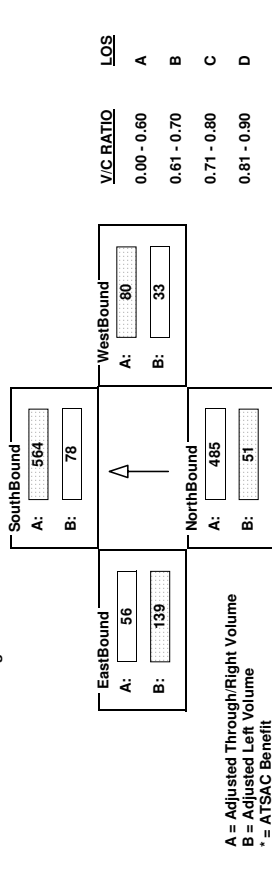

A = Adjusted Through/Right Volume
 B = Adjusted Left Volume
 * = ATSAC Benefit

Results
 North/South Critical Movements = B(N/B) + A(S/B)
 West/East Critical Movements = A(W/B) + B(E/B)
 V/C = $\frac{51 + 564 + 80 + 139}{1425} = 0.515$ LOS = A

CalcaDB

INTERSECTION DATA SUMMARY SHEET

N/S: W/E: I/S No:
 AM/PM: Comments:
 COUNT DATE: STUDY DATE: GROWTH FACTOR:

Volume/Lane/Signal Configurations

	NORTHBOUND			SOUTHBOUND			WESTBOUND			EASTBOUND		
	LT	TH	RT	LT	TH	RT	LT	TH	RT	LT	TH	RT
EXISTING	0	511	142	142	600	0	854	0	74	0	0	0
AMBIENT												
RELATED												
PROJECT												
TOTAL	0	511	142	142	600	0	854	0	74	0	0	0

LANE	1	1	1	1	2	1	1	1	1	1	1	1
PHASING	↓	↓	↓	↓	↓	↓	↓	↓	↓	↓	↓	↓
SIGNAL	Perm	OLA	OLA	Prot-Fix	Auto	Auto	Auto	Auto	Auto	Split	Auto	Auto

Critical Movements Diagram

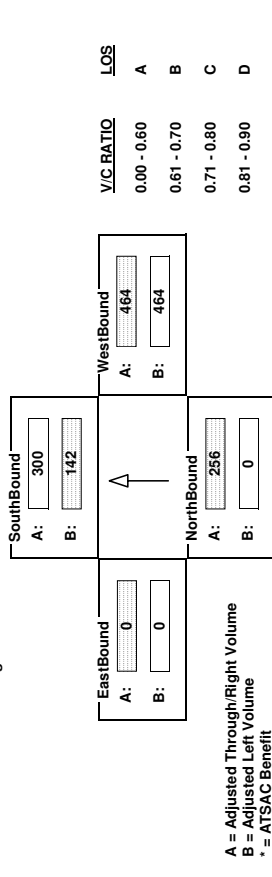

A = Adjusted Through/Right Volume
 B = Adjusted Left Volume
 * = ATSAC Benefit

Results
 North/South Critical Movements = A(N/B) + B(S/B)
 West/East Critical Movements = A(W/B) + A(E/B)
 V/C = $\frac{256 + 142 + 464 + 0}{1375} = 0.557$ LOS = A

INTERSECTION DATA SUMMARY SHEET

N/S: W/E: I/S No:
 AM/PM: Comments:
 COUNT DATE: STUDY DATE: GROWTH FACTOR:

Volume/Lane/Signal Configurations

	NORTHBOUND			SOUTHBOUND			WESTBOUND			EASTBOUND		
	LT	TH	RT	LT	TH	RT	LT	TH	RT	LT	TH	RT
EXISTING	188	744	284	262	336	125	203	848	166	119	1254	203
AMBIENT												
RELATED												
PROJECT												
TOTAL	188	744	284	262	336	125	203	848	166	119	1254	203

LANE:

SIGNAL:

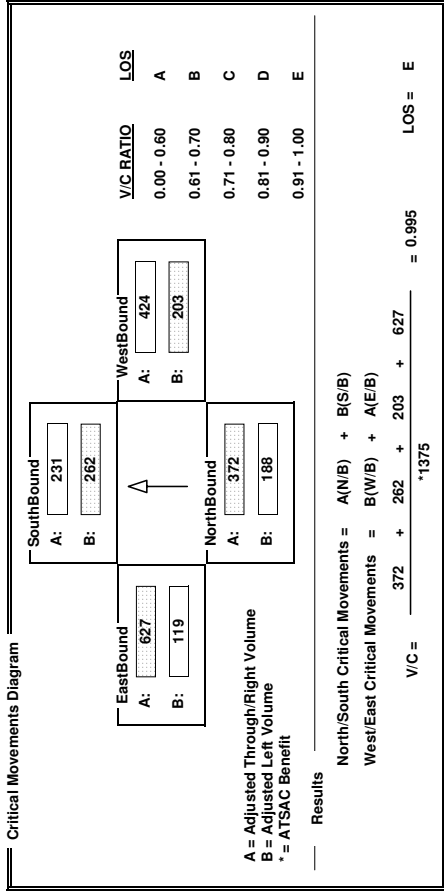

INTERSECTION DATA SUMMARY SHEET

N/S: W/E: I/S No:
 AM/PM: Comments:
 COUNT DATE: STUDY DATE: GROWTH FACTOR:

Volume/Lane/Signal Configurations

	NORTHBOUND			SOUTHBOUND			WESTBOUND			EASTBOUND		
	LT	TH	RT	LT	TH	RT	LT	TH	RT	LT	TH	RT
EXISTING	218	646	124	79	416	102	93	408	55	131	840	316
AMBIENT												
RELATED												
PROJECT												
TOTAL	218	646	124	79	416	102	93	408	55	131	840	316

LANE:

SIGNAL:

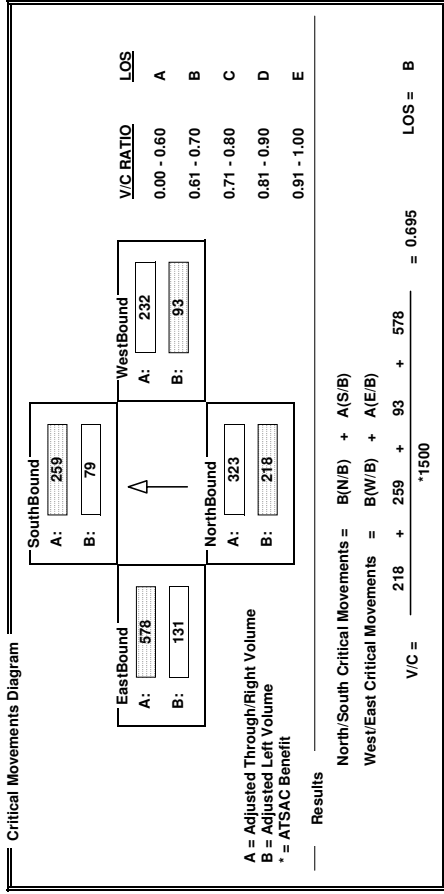

CalcaDB

INTERSECTION DATA SUMMARY SHEET

N/S: Sepulveda Blvd W/E: Imperial Hwy I/S No: 71
 AM/PM: **PM** Comments: MAP 1 Future 2013 with Project
 COUNT DATE: STUDY DATE: GROWTH FACTOR:

Volume/Lane/Signal Configurations

	NORTHBOUND			SOUTHBOUND			WESTBOUND			EASTBOUND		
	LT	TH	RT	LT	TH	RT	LT	TH	RT	LT	TH	RT
EXISTING	174	1605	1166	336	2257	80	235	314	343	166	297	165
AMBIENT												
RELATED												
PROJECT												
TOTAL	174	1605	1166	336	2257	80	235	314	343	166	297	165

LANE	1	2	3	1	2	3	1	2	3	1	2	3
PHASING	↓	↓	↓	↓	↓	↓	↓	↓	↓	↓	↓	↓
RTOR	Auto	Auto	Auto	Auto	Auto	Auto	Auto	Auto	Auto	Auto	Auto	Auto
SIGNAL	Prot-Fix	Prot-Fix	Auto	Prot-Fix	Prot-Fix	Auto	Prot-Fix	OLA	OLA	Prot-Fix	Prot-Fix	Auto

Critical Movements Diagram

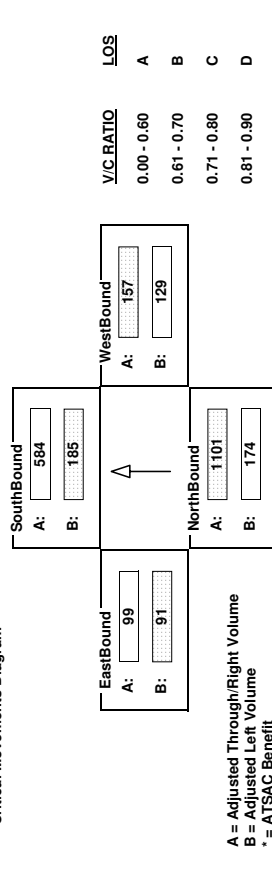

A = Adjusted Through/Right Volume
 B = Adjusted Left Volume
 * = ATSAC Benefit

Results

North/South Critical Movements = A(N/B) + B(S/B)
 West/East Critical Movements = A(W/B) + B(E/B)

V/C = $\frac{1101 + 185 + 157 + 91}{1375} = 1.046$ LOS = F

CalcaDB

INTERSECTION DATA SUMMARY SHEET

N/S: Sepulveda Blvd W/E: La Tijera Blvd I/S No: 101
 AM/PM: **PM** Comments: MAP 1 Future 2013 with Project
 COUNT DATE: STUDY DATE: GROWTH FACTOR:

Volume/Lane/Signal Configurations

	NORTHBOUND			SOUTHBOUND			WESTBOUND			EASTBOUND		
	LT	TH	RT	LT	TH	RT	LT	TH	RT	LT	TH	RT
EXISTING	152	1568	158	73	1222	81	249	384	58	88	442	76
AMBIENT												
RELATED												
PROJECT												
TOTAL	152	1568	158	73	1222	81	249	384	58	88	442	76

LANE	1	2	3	1	2	3	1	2	3	1	2	3
PHASING	↓	↓	↓	↓	↓	↓	↓	↓	↓	↓	↓	↓
RTOR	OLA	OLA	OLA	OLA	OLA	OLA	Perm	Auto	Auto	OLA	OLA	OLA
SIGNAL	Prot-Fix	Prot-Fix	OLA	Prot-Fix	Prot-Fix	OLA	Perm	Auto	Auto	Prot-Fix	Prot-Fix	OLA

Critical Movements Diagram

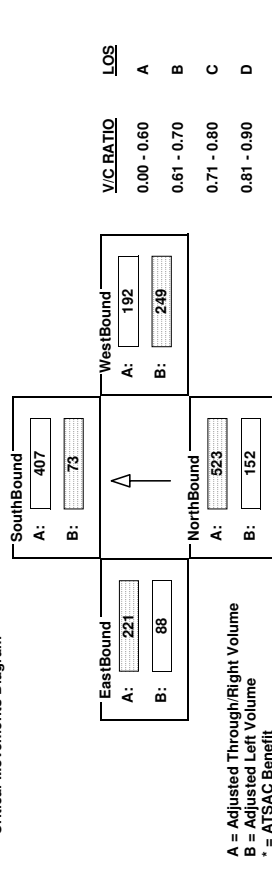

A = Adjusted Through/Right Volume
 B = Adjusted Left Volume
 * = ATSAC Benefit

Results

North/South Critical Movements = A(N/B) + B(S/B)
 West/East Critical Movements = B(W/B) + A(E/B)

V/C = $\frac{523 + 73 + 249 + 221}{1375} = 0.705$ LOS = C

CalcaDB

INTERSECTION DATA SUMMARY SHEET

N/S: W/E: I/S No:
 AM/PM: Comments:
 COUNT DATE: STUDY DATE: GROWTH FACTOR:

Volume/Lane/Signal Configurations

	NORTHBOUND			SOUTHBOUND			WESTBOUND			EASTBOUND		
	LT	TH	RT	LT	TH	RT	LT	TH	RT	LT	TH	RT
EXISTING	44	1854	30	123	2020	344	36	74	86	227	68	72
AMBIENT												
RELATED												
PROJECT												
TOTAL	44	1854	30	123	2020	344	36	74	86	227	68	72

LANE	1	2	3	4	5	6	7	8	9	10	11	12
PHASING	1	2	1	1	1	1	1	1	1	1	1	1
RTOR	Auto	Auto	Auto	Auto	Auto	Auto	Auto	Auto	Auto	Auto	Auto	Auto
SIGNAL	Perm	Perm	Auto	Auto	Auto	Auto	Auto	Auto	Auto	Auto	Auto	Auto

Critical Movements Diagram

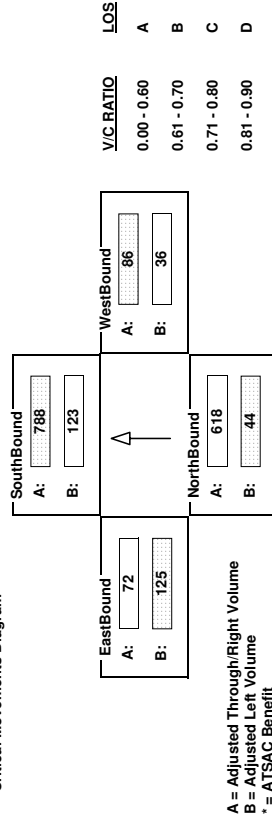

Results

North/South Critical Movements = B(N/B) + A(S/B)
 West/East Critical Movements = A(W/B) + B(E/B)
 V/C = $\frac{44 + 788 + 86 + 125}{1425} = 0.662$ LOS = B

CalcaDB

INTERSECTION DATA SUMMARY SHEET

N/S: W/E: I/S No:
 AM/PM: Comments:
 COUNT DATE: STUDY DATE: GROWTH FACTOR:

Volume/Lane/Signal Configurations

	NORTHBOUND			SOUTHBOUND			WESTBOUND			EASTBOUND		
	LT	TH	RT	LT	TH	RT	LT	TH	RT	LT	TH	RT
EXISTING	0	616	81	198	787	0	712	0	169	0	0	0
AMBIENT												
RELATED												
PROJECT												
TOTAL	0	616	81	198	787	0	712	0	169	0	0	0

LANE	1	2	3	4	5	6	7	8	9	10	11	12
PHASING	1	1	1	1	1	1	1	1	1	1	1	1
RTOR	OLA	OLA	OLA	OLA	OLA	OLA	OLA	OLA	OLA	OLA	OLA	OLA
SIGNAL	Perm	Perm	Auto	Auto	Auto	Auto	Auto	Auto	Auto	Auto	Auto	Auto

Critical Movements Diagram

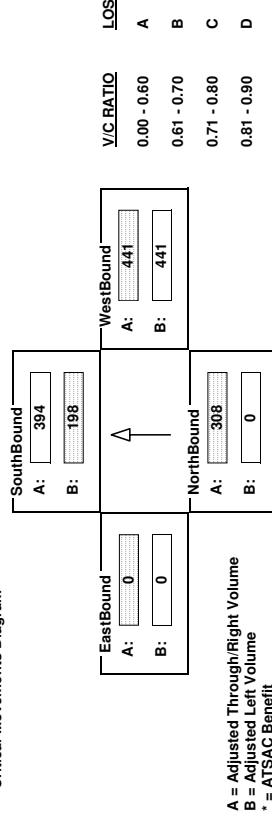

Results

North/South Critical Movements = A(N/B) + B(S/B)
 West/East Critical Movements = A(W/B) + A(E/B)
 V/C = $\frac{308 + 198 + 441 + 0}{1375} = 0.619$ LOS = B

CalcaDB

INTERSECTION DATA SUMMARY SHEET

N/S: W/E: I/S No:

AM/PM: Comments:

COUNT DATE: STUDY DATE: GROWTH FACTOR:

Volume/Lane/Signal Configurations

	NORTHBOUND			SOUTHBOUND			WESTBOUND			EASTBOUND		
	LT	TH	RT	LT	TH	RT	LT	TH	RT	LT	TH	RT
EXISTING	254	517	128	62	442	119	66	735	96	88	233	155
AMBIENT												
RELATED												
PROJECT												
TOTAL	254	517	128	62	442	119	66	735	96	88	233	155

LANE: 1 2 1 1 1 1 1 1 1 1 1 1 1

Phasing: RTOR Auto Perm Auto Perm RTOR Phasing RTOR

SIGNAL: Perm Auto Auto Perm Auto Perm Perm Auto Auto

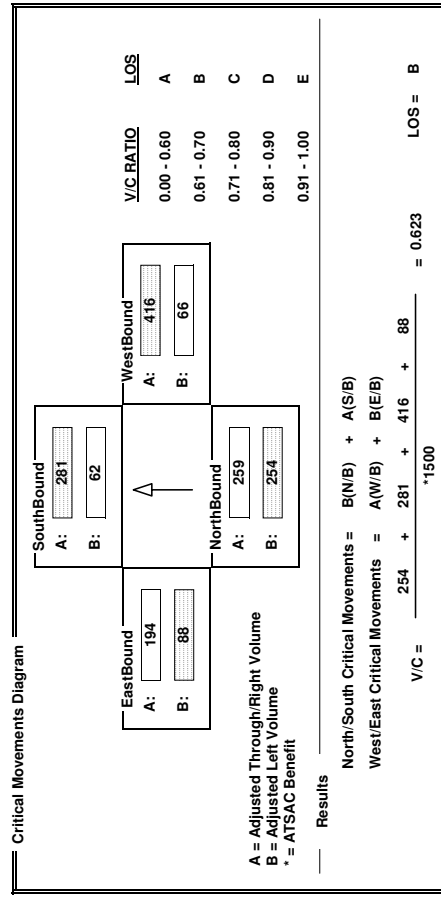

CalcaDB

INTERSECTION DATA SUMMARY SHEET

N/S: W/E: I/S No:

AM/PM: Comments:

COUNT DATE: STUDY DATE: GROWTH FACTOR:

Volume/Lane/Signal Configurations

	NORTHBOUND			SOUTHBOUND			WESTBOUND			EASTBOUND		
	LT	TH	RT	LT	TH	RT	LT	TH	RT	LT	TH	RT
EXISTING	118	590	80	68	698	27	129	1176	205	25	608	66
AMBIENT												
RELATED												
PROJECT												
TOTAL	118	590	80	68	698	27	129	1176	205	25	608	66

LANE: 1 2 1 1 1 1 1 1 1 1 1 1 1

Phasing: RTOR Auto Prot-Fix Auto Prot-Fix RTOR Phasing RTOR

SIGNAL: Prot-Fix Auto Auto Prot-Fix Auto Prot-Fix Auto Auto

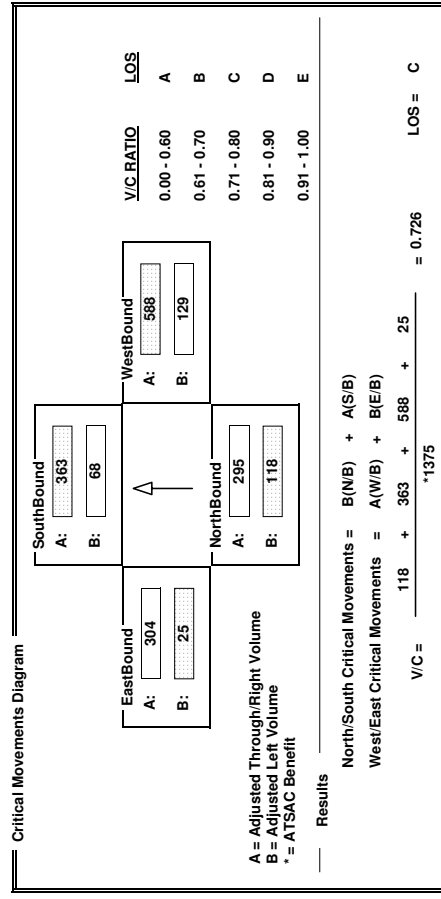

INTERSECTION DATA SUMMARY SHEET

N/S: Sepulveda Blvd W/E: Imperial Hwy I/S No: 71
 AM/PM: AM Comments: MAP 2 Future 2013 w/o Project
 COUNT DATE: STUDY DATE: GROWTH FACTOR:

Volume/Lane/Signal Configurations

	NORTHBOUND			SOUTHBOUND			WESTBOUND			EASTBOUND		
	LT	TH	RT	LT	TH	RT	LT	TH	RT	LT	TH	RT
EXISTING	135	1664	697	276	2074	176	197	327	287	218	272	193
AMBIENT												
RELATED												
PROJECT												
TOTAL	135	1664	697	276	2074	176	197	327	287	218	272	193

LANE: 1 3 1 2 3 1 2 2 2 2 2 3 1

SIGNAL: Prot-Fix RTOR Phasing RTOR Prot-Fix Auto Auto OLA Prot-Fix Auto

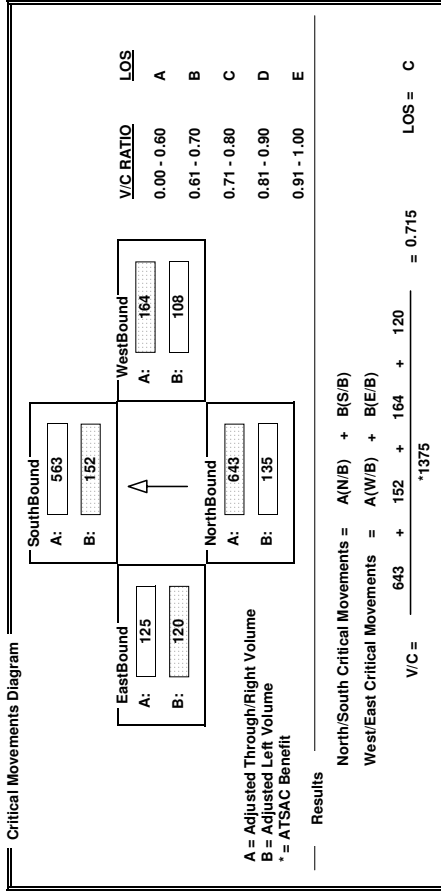

INTERSECTION DATA SUMMARY SHEET

N/S: Sepulveda Blvd W/E: La Tijera Blvd I/S No: 101
 AM/PM: AM Comments: MAP 2 Future 2013 w/o Project
 COUNT DATE: STUDY DATE: GROWTH FACTOR:

Volume/Lane/Signal Configurations

	NORTHBOUND			SOUTHBOUND			WESTBOUND			EASTBOUND		
	LT	TH	RT	LT	TH	RT	LT	TH	RT	LT	TH	RT
EXISTING	100	1375	121	55	1085	56	312	196	35	46	316	78
AMBIENT												
RELATED												
PROJECT												
TOTAL	100	1375	121	55	1085	56	312	196	35	46	316	78

LANE: 1 3 1 1 3 1 1 1 2 1 1 2 1

SIGNAL: Prot-Fix RTOR Phasing RTOR Prot-Fix OLA OLA Prot-Fix Auto OLA

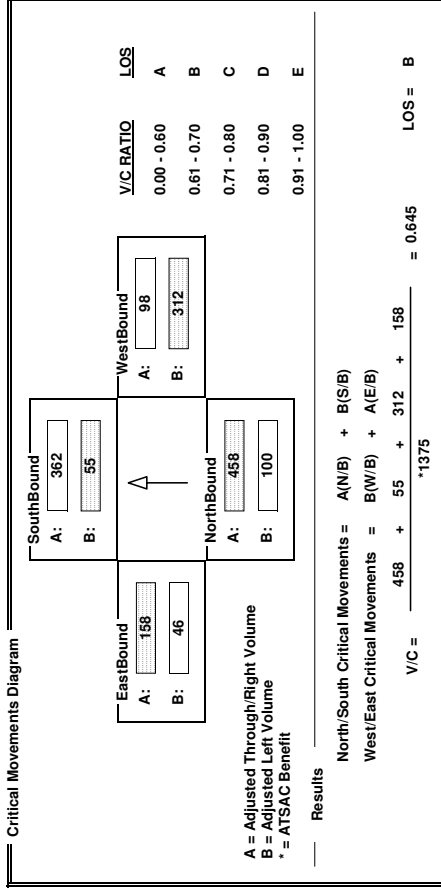

CalcaDB

INTERSECTION DATA SUMMARY SHEET

N/S: W/E: I/S No:

AM/PM: Comments: GROWTH FACTOR:

COUNT DATE: STUDY DATE:

Volume/Lane/Signal Configurations

	NORTHBOUND			SOUTHBOUND			WESTBOUND			EASTBOUND		
	LT	TH	RT	LT	TH	RT	LT	TH	RT	LT	TH	RT
EXISTING	0	902	116	159	424	0	842	0	69	0	0	0
AMBIENT												
RELATED												
PROJECT												
TOTAL	0	902	116	159	424	0	842	0	69	0	0	0

LANE:

SIGNAL:

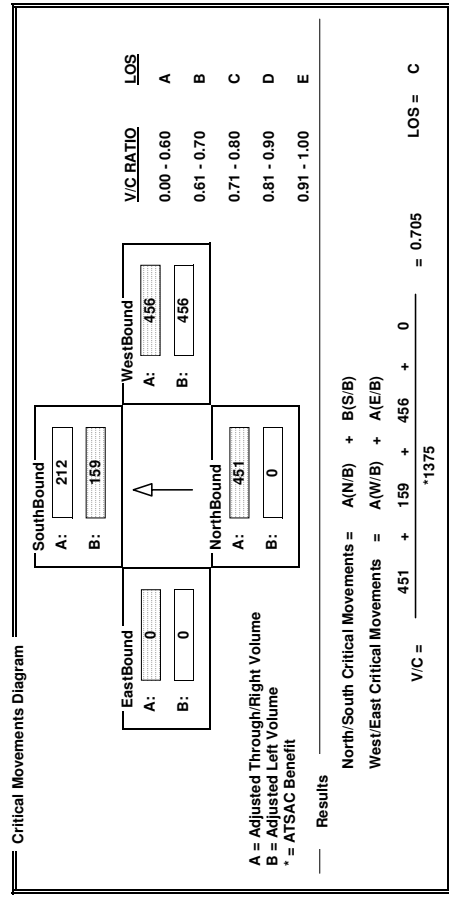

CalcaDB

INTERSECTION DATA SUMMARY SHEET

N/S: W/E: I/S No:

AM/PM: Comments: GROWTH FACTOR:

COUNT DATE: STUDY DATE:

Volume/Lane/Signal Configurations

	NORTHBOUND			SOUTHBOUND			WESTBOUND			EASTBOUND		
	LT	TH	RT	LT	TH	RT	LT	TH	RT	LT	TH	RT
EXISTING	42	1943	15	65	1193	155	28	94	244	594	42	54
AMBIENT												
RELATED												
PROJECT												
TOTAL	42	1943	15	65	1193	155	28	94	244	594	42	54

LANE:

SIGNAL:

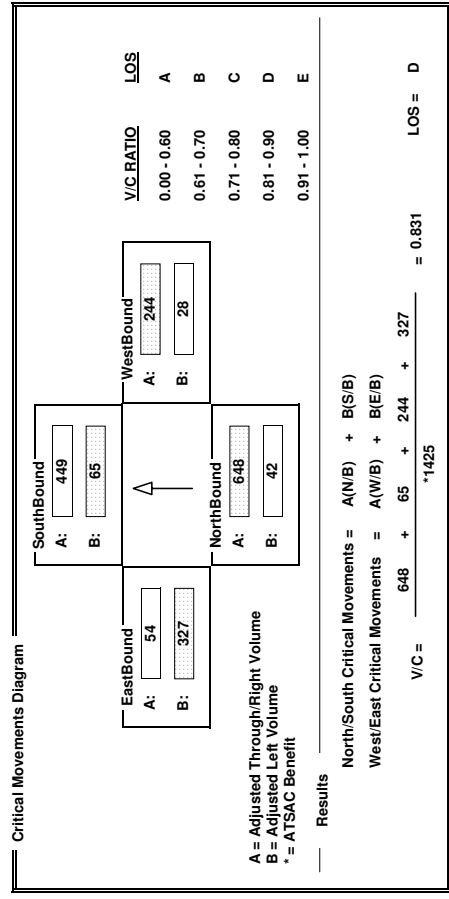

CalcaDB

INTERSECTION DATA SUMMARY SHEET

N/S: W/E: I/S No:

AM/PM: Comments:

COUNT DATE: STUDY DATE: GROWTH FACTOR:

Volume/Lane/Signal Configurations

	NORTHBOUND			SOUTHBOUND			WESTBOUND			EASTBOUND		
	LT	TH	RT	LT	TH	RT	LT	TH	RT	LT	TH	RT
EXISTING	109	698	256	67	581	26	129	835	58	23	1051	65
AMBIENT												
RELATED												
PROJECT												
TOTAL	109	698	256	67	581	26	129	835	58	23	1051	65

LANE: 1 2 1 1 1 1 1 1 2 1 1 2 1

SIGNAL: Prot-Fix RTOR Auto Prot-Fix RTOR Auto Prot-Fix RTOR Auto Prot-Fix RTOR Auto

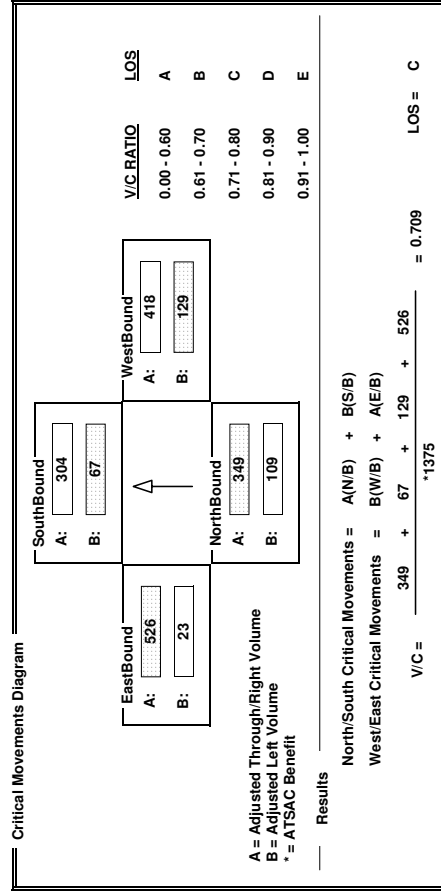

CalcaDB

INTERSECTION DATA SUMMARY SHEET

N/S: W/E: I/S No:

AM/PM: Comments:

COUNT DATE: STUDY DATE: GROWTH FACTOR:

Volume/Lane/Signal Configurations

	NORTHBOUND			SOUTHBOUND			WESTBOUND			EASTBOUND		
	LT	TH	RT	LT	TH	RT	LT	TH	RT	LT	TH	RT
EXISTING	225	421	119	122	319	121	89	454	61	96	394	169
AMBIENT												
RELATED												
PROJECT												
TOTAL	225	421	119	122	319	121	89	454	61	96	394	169

LANE: 1 2 1 1 1 1 1 1 1 1 1 1 1

SIGNAL: Perm RTOR Auto Perm RTOR Auto Perm RTOR Auto Perm RTOR Auto

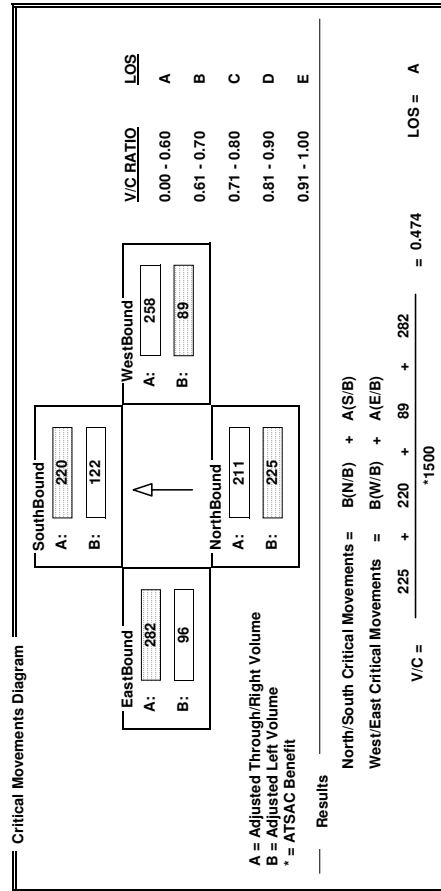

CalcaDB

INTERSECTION DATA SUMMARY SHEET

N/S: Sepulveda Blvd W/E: Imperial Hwy I/S No: 71
 AM/PM: MD Comments: MAP 2 Future 2013 w/o Project
 COUNT DATE: STUDY DATE: GROWTH FACTOR:

Volume/Lane/Signal Configurations

	NORTHBOUND			SOUTHBOUND			WESTBOUND			EASTBOUND		
	LT	TH	RT	LT	TH	RT	LT	TH	RT	LT	TH	RT
EXISTING	166	1279	807	378	1688	68	185	306	271	281	279	154
AMBIENT												
RELATED												
PROJECT												
TOTAL	166	1279	807	378	1688	68	185	306	271	281	279	154
LANE	1	3	1	2	3	1	2	2	2	2	3	1

SIGNAL	Phasing			RTOR			Phasing			RTOR		
	Prot-Fix	Auto	OLA	Prot-Fix	Auto	OLA	Prot-Fix	Auto	OLA	Prot-Fix	Auto	OLA
	Prot-Fix	Auto	OLA	Prot-Fix	Auto	OLA	Prot-Fix	Auto	OLA	Prot-Fix	Auto	OLA

Critical Movements Diagram

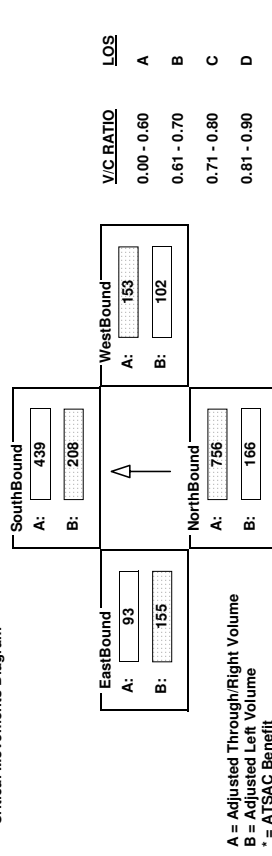

CalcaDB

INTERSECTION DATA SUMMARY SHEET

N/S: Sepulveda Blvd W/E: La Tijera Blvd I/S No: 101
 AM/PM: MD Comments: MAP 2 Future 2013 w/o Project
 COUNT DATE: STUDY DATE: GROWTH FACTOR:

Volume/Lane/Signal Configurations

	NORTHBOUND			SOUTHBOUND			WESTBOUND			EASTBOUND		
	LT	TH	RT	LT	TH	RT	LT	TH	RT	LT	TH	RT
EXISTING	106	1195	272	103	1127	48	277	214	89	78	258	69
AMBIENT												
RELATED												
PROJECT												
TOTAL	106	1195	272	103	1127	48	277	214	89	78	258	69
LANE	1	3	1	1	3	1	1	2	1	1	2	1

SIGNAL	Phasing			RTOR			Phasing			RTOR		
	Prot-Fix	Auto	OLA	Prot-Fix	Auto	OLA	Prot-Fix	Auto	OLA	Prot-Fix	Auto	OLA
	Prot-Fix	Auto	OLA	Prot-Fix	Auto	OLA	Prot-Fix	Auto	OLA	Prot-Fix	Auto	OLA

Critical Movements Diagram

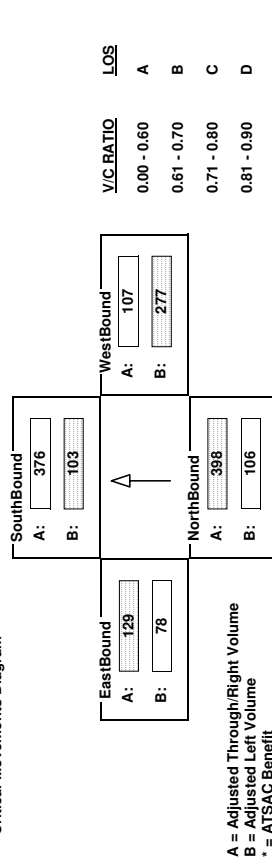

CalcaDB

INTERSECTION DATA SUMMARY SHEET

N/S: W/E: I/S No:
 AM/PM: Comments:
 COUNT DATE: STUDY DATE: GROWTH FACTOR:

Volume/Lane/Signal Configurations

	NORTHBOUND			SOUTHBOUND			WESTBOUND			EASTBOUND		
	LT	TH	RT	LT	TH	RT	LT	TH	RT	LT	TH	RT
EXISTING	53	1441	35	78	1466	237	35	63	82	255	50	57
AMBIENT												
RELATED												
PROJECT												
TOTAL	53	1441	35	78	1466	237	35	63	82	255	50	57

LANE: 1 3 1 1 1 2 1 1 0 1 1 1 1

SIGNAL: Phasing RTOR RTOR RTOR RTOR RTOR RTOR RTOR RTOR

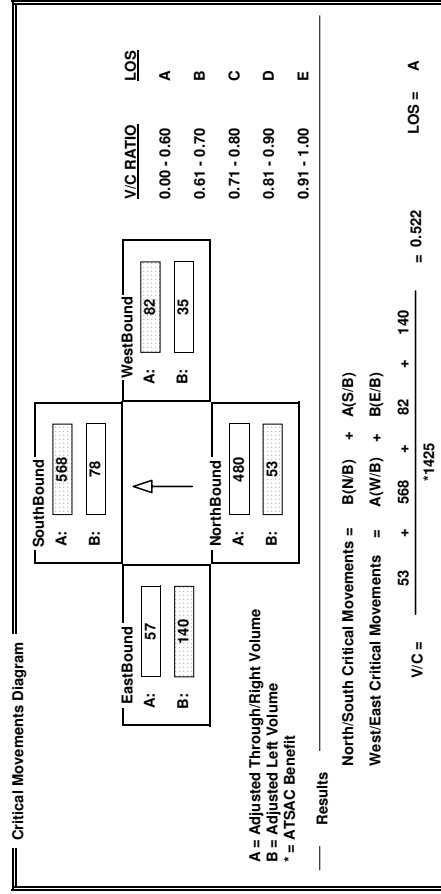

CalcaDB

INTERSECTION DATA SUMMARY SHEET

N/S: W/E: I/S No:
 AM/PM: Comments:
 COUNT DATE: STUDY DATE: GROWTH FACTOR:

Volume/Lane/Signal Configurations

	NORTHBOUND			SOUTHBOUND			WESTBOUND			EASTBOUND		
	LT	TH	RT	LT	TH	RT	LT	TH	RT	LT	TH	RT
EXISTING	0	505	144	144	613	0	869	0	74	0	0	0
AMBIENT												
RELATED												
PROJECT												
TOTAL	0	505	144	144	613	0	869	0	74	0	0	0

LANE: 1 1 1 1 1 2 1 1 1 1 1 1 1

SIGNAL: Phasing RTOR RTOR RTOR RTOR RTOR RTOR RTOR

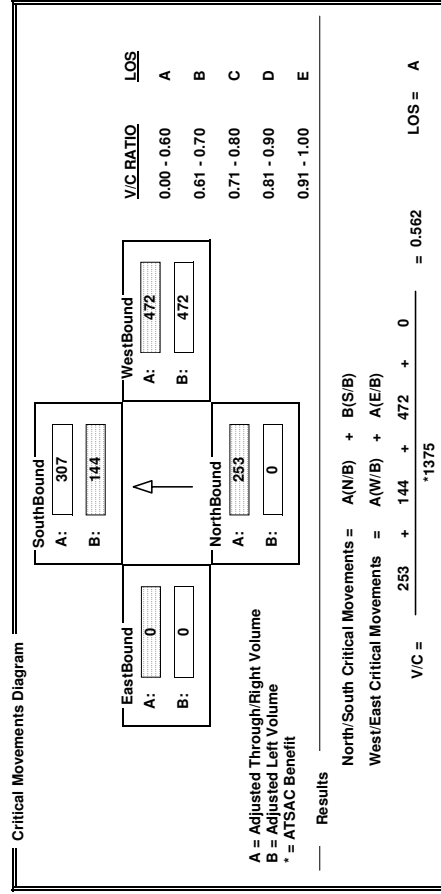

CalcaDB

INTERSECTION DATA SUMMARY SHEET

N/S: Airport Blvd W/E: Manchester Ave I/S No: 9
 AM/PM: **PM** Comments: MAP 2 Future 2013 w/o Project
 COUNT DATE: STUDY DATE: GROWTH FACTOR:

Volume/Lane/Signal Configurations

	NORTHBOUND		SOUTHBOUND		WESTBOUND		EASTBOUND		
	LT	RT	LT	RT	LT	RT	LT	RT	
EXISTING	189	766	297	328	205	845	119	1263	245
AMBIENT									
RELATED									
PROJECT									
TOTAL	189	766	297	328	205	845	119	1263	245

LANE: 1 2 1 1 1 1 1 1 1 1 1

SIGNAL: Prot-Fix Auto RTOR Phasing RTOR Auto Prot-Fix Auto RTOR Auto Prot-Fix Auto

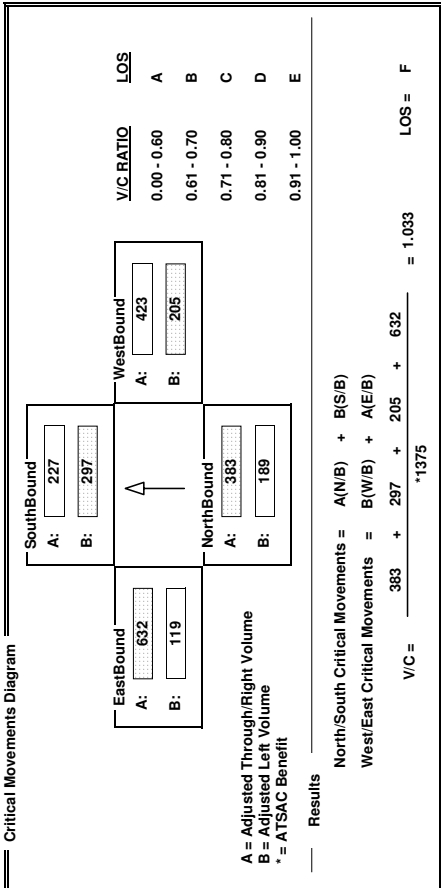

Developed by Chun Wong, 12/04

CalcaDB

INTERSECTION DATA SUMMARY SHEET

N/S: Aviation Blvd W/E: Arbor Vitae St I/S No: 10
 AM/PM: **PM** Comments: MAP 2 Future 2013 w/o Project
 COUNT DATE: STUDY DATE: GROWTH FACTOR:

Volume/Lane/Signal Configurations

	NORTHBOUND		SOUTHBOUND		WESTBOUND		EASTBOUND		
	LT	RT	LT	RT	LT	RT	LT	RT	
EXISTING	226	629	87	419	93	432	136	923	317
AMBIENT									
RELATED									
PROJECT									
TOTAL	226	629	87	419	93	432	136	923	317

LANE: 1 2 1 1 1 1 1 1 1 1

SIGNAL: Perm Auto Auto Perm Auto Perm Auto Perm Auto

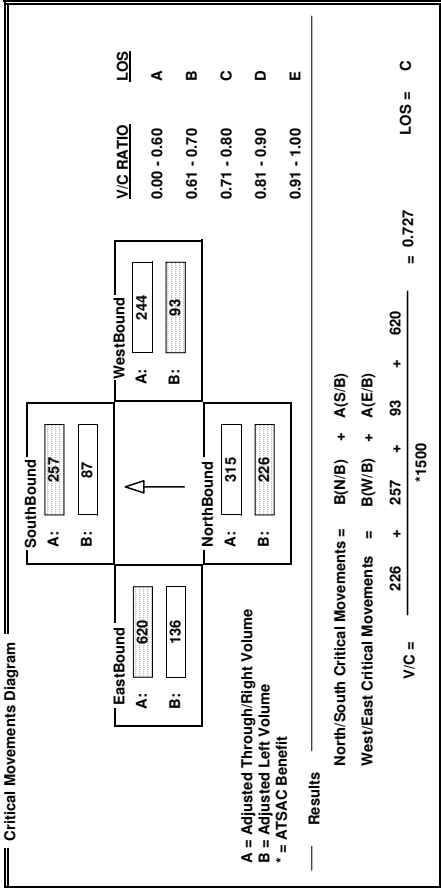

Developed by Chun Wong, 12/04

CalcaDB

INTERSECTION DATA SUMMARY SHEET

N/S: W/E: I/S No:
 AM/PM: **PM** Comments:
 COUNT DATE: STUDY DATE: GROWTH FACTOR:

Volume/Lane/Signal Configurations

	NORTHBOUND			SOUTHBOUND			WESTBOUND			EASTBOUND		
	LT	TH	RT	LT	TH	RT	LT	TH	RT	LT	TH	RT
EXISTING	176	1586	1176	352	2273	118	239	333	350	173	304	166
AMBIENT												
RELATED												
PROJECT												
TOTAL	176	1586	1176	352	2273	118	239	333	350	173	304	166

LANE: 1 3 1 2 3 1 2 2 2 2 2 3 1

SIGNAL: Prot-Fix RTOR Phasing RTOR Prot-Fix RTOR Prot-Fix RTOR
 Auto Auto OLA OLA

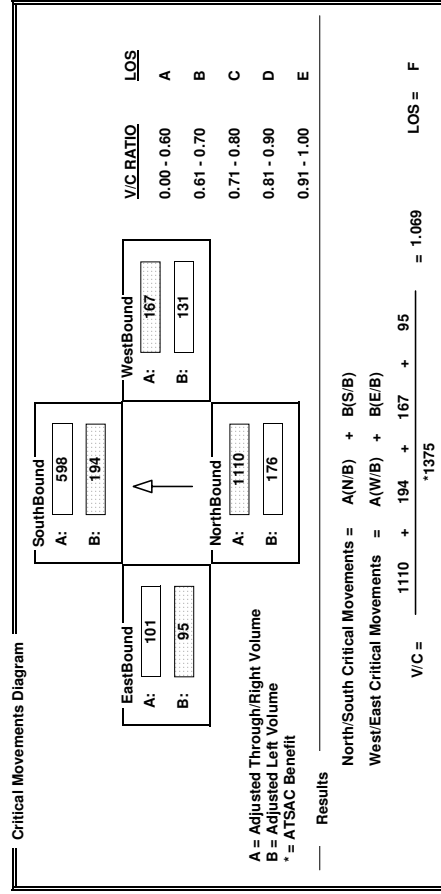

CalcaDB

INTERSECTION DATA SUMMARY SHEET

N/S: W/E: I/S No:
 AM/PM: **PM** Comments:
 COUNT DATE: STUDY DATE: GROWTH FACTOR:

Volume/Lane/Signal Configurations

	NORTHBOUND			SOUTHBOUND			WESTBOUND			EASTBOUND		
	LT	TH	RT	LT	TH	RT	LT	TH	RT	LT	TH	RT
EXISTING	164	1537	162	82	1194	83	261	386	59	88	444	82
AMBIENT												
RELATED												
PROJECT												
TOTAL	164	1537	162	82	1194	83	261	386	59	88	444	82

LANE: 1 3 1 1 3 1 1 1 2 1 1 2 1

SIGNAL: Prot-Fix RTOR Phasing RTOR Prot-Fix RTOR
 OLA OLA Auto OLA

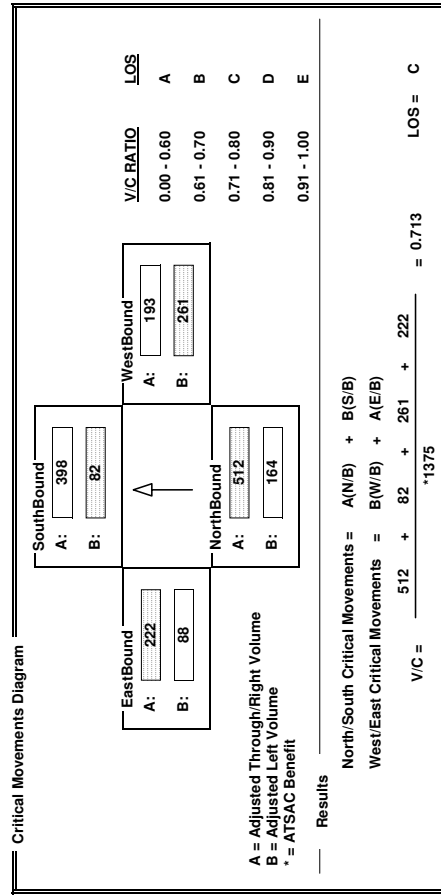

CalcaDB

INTERSECTION DATA SUMMARY SHEET

N/S: Sepulveda Blvd W/E: 76th St/77th St I/S No: 136
 AM/PM: **PM** Comments: MAP 2 Future 2013 w/o Project
 COUNT DATE: STUDY DATE: GROWTH FACTOR:

Volume/Lane/Signal Configurations

	NORTHBOUND			SOUTHBOUND			WESTBOUND			EASTBOUND		
	LT	TH	RT	LT	TH	RT	LT	TH	RT	LT	TH	RT
EXISTING	45	1827	29	125	1998	346	37	86	87	258	74	68
AMBIENT												
RELATED												
PROJECT												
TOTAL	45	1827	29	125	1998	346	37	86	87	258	74	68
LANE	1	3	1	1	2	1	1	1	1	2	1	1
SIGNAL	Phasing	RTOR	Auto	Phasing	RTOR	Perm	Auto	Phasing	RTOR	Auto	Split	Auto

Critical Movements Diagram

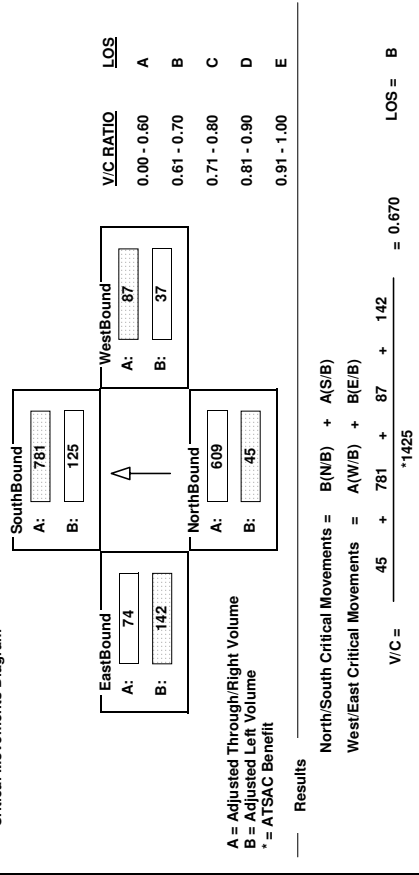

CalcaDB

INTERSECTION DATA SUMMARY SHEET

N/S: La Cienega Blvd W/E: I-405 SB Ramps n/o Century I/S No: 96
 AM/PM: **PM** Comments: MAP 2 Future 2013 w/o Project
 COUNT DATE: STUDY DATE: GROWTH FACTOR:

Volume/Lane/Signal Configurations

	NORTHBOUND			SOUTHBOUND			WESTBOUND			EASTBOUND		
	LT	TH	RT	LT	TH	RT	LT	TH	RT	LT	TH	RT
EXISTING	0	612	83	212	798	0	738	0	170	0	0	0
AMBIENT												
RELATED												
PROJECT												
TOTAL	0	612	83	212	798	0	738	0	170	0	0	0
LANE	1	1	1	1	2	1	1	1	1	1	1	1
SIGNAL	Phasing	RTOR	OLA	Phasing	RTOR	Auto	Phasing	RTOR	Auto	Split	Auto	Auto

Critical Movements Diagram

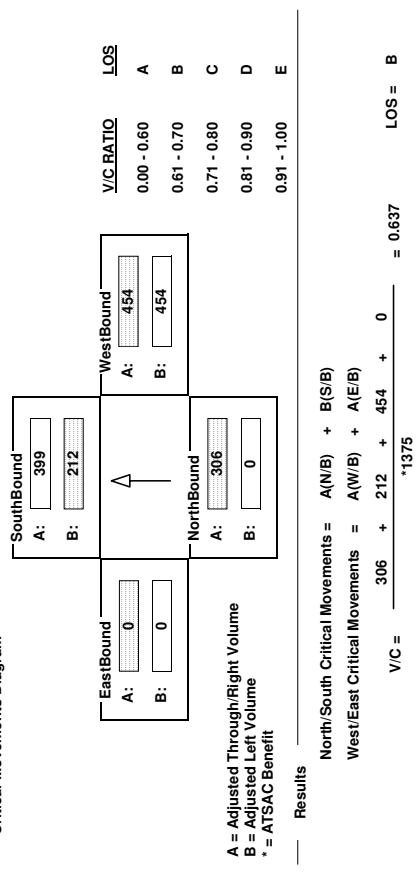

INTERSECTION DATA SUMMARY SHEET

N/S: W/E: I/S No:
 AM/PM: Comments:
 COUNT DATE: STUDY DATE: GROWTH FACTOR:

Volume/Lane/Signal Configurations

	NORTHBOUND			SOUTHBOUND			WESTBOUND			EASTBOUND		
	LT	TH	RT	LT	TH	RT	LT	TH	RT	LT	TH	RT
EXISTING	118	618	84	72	714	27	133	1200	205	25	608	78
AMBIENT												
RELATED												
PROJECT												
TOTAL	118	618	84	72	714	27	133	1200	205	25	608	78

LANE:

Signal:

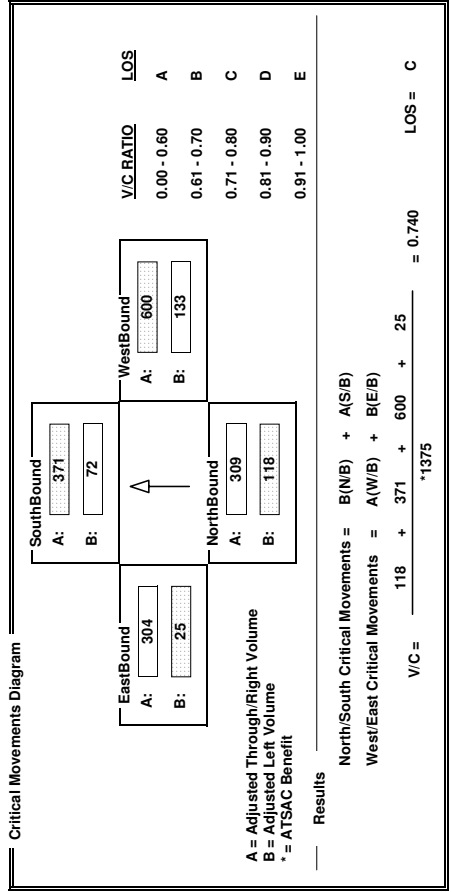

INTERSECTION DATA SUMMARY SHEET

N/S: W/E: I/S No:
 AM/PM: Comments:
 COUNT DATE: STUDY DATE: GROWTH FACTOR:

Volume/Lane/Signal Configurations

	NORTHBOUND			SOUTHBOUND			WESTBOUND			EASTBOUND		
	LT	TH	RT	LT	TH	RT	LT	TH	RT	LT	TH	RT
EXISTING	254	541	128	62	446	123	66	767	96	92	245	155
AMBIENT												
RELATED												
PROJECT												
TOTAL	254	541	128	62	446	123	66	767	96	92	245	155

LANE:

Signal:

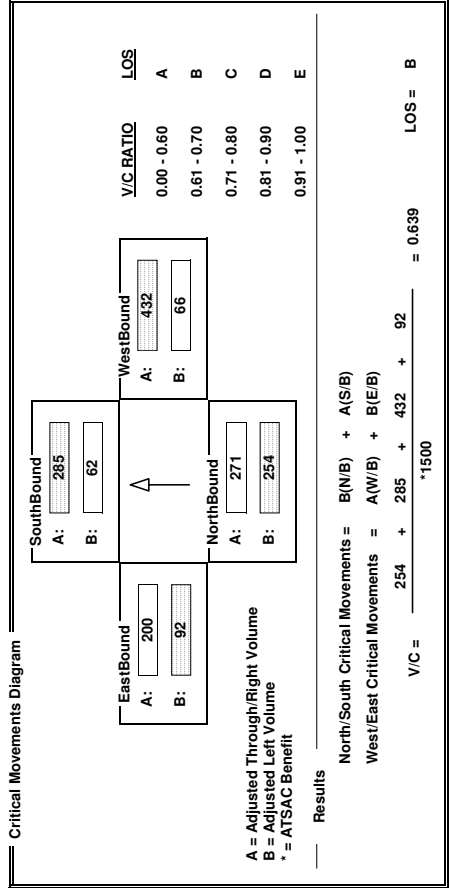

CalcaDB

INTERSECTION DATA SUMMARY SHEET

N/S: Sepulveda Blvd W/E: Imperial Hwy I/S No: 71
 AM/PM: AM Comments: MAP 2 Future 2013 with Project
 COUNT DATE: STUDY DATE: GROWTH FACTOR:

Volume/Lane/Signal Configurations

	NORTHBOUND			SOUTHBOUND			WESTBOUND			EASTBOUND		
	LT	TH	RT	LT	TH	RT	LT	TH	RT	LT	TH	RT
EXISTING	135	1700	697	296	2094	176	197	327	303	222	276	193
AMBIENT												
RELATED												
PROJECT												
TOTAL	135	1700	697	296	2094	176	197	327	303	222	276	193
LANE	1	3	1	2	3	1	2	2	2	2	3	1
SIGNAL	Prot-Fix Auto			Prot-Fix Auto			Prot-Fix OLA			Prot-Fix Auto		

Critical Movements Diagram

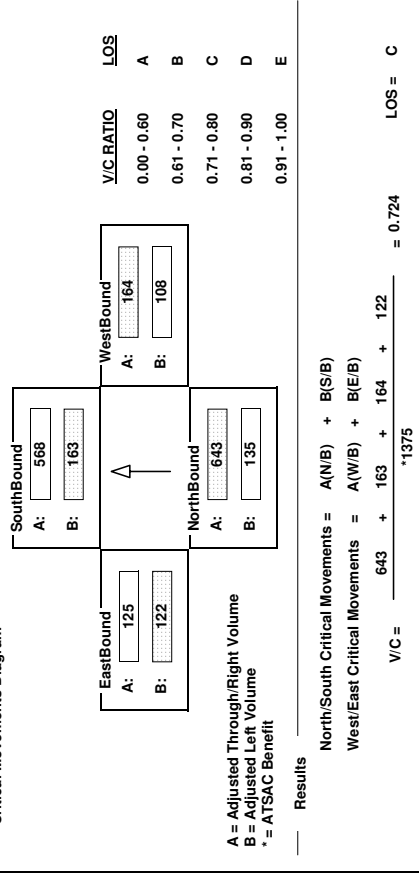

CalcaDB

INTERSECTION DATA SUMMARY SHEET

N/S: Sepulveda Blvd W/E: La Tijera Blvd I/S No: 101
 AM/PM: AM Comments: MAP 2 Future 2013 with Project
 COUNT DATE: STUDY DATE: GROWTH FACTOR:

Volume/Lane/Signal Configurations

	NORTHBOUND			SOUTHBOUND			WESTBOUND			EASTBOUND		
	LT	TH	RT	LT	TH	RT	LT	TH	RT	LT	TH	RT
EXISTING	100	1455	129	55	1157	56	332	196	35	46	316	78
AMBIENT												
RELATED												
PROJECT												
TOTAL	100	1455	129	55	1157	56	332	196	35	46	316	78
LANE	1	3	1	1	3	1	1	2	1	1	2	1
SIGNAL	Prot-Fix OLA			Prot-Fix OLA			Perm Auto			Prot-Fix OLA		

Critical Movements Diagram

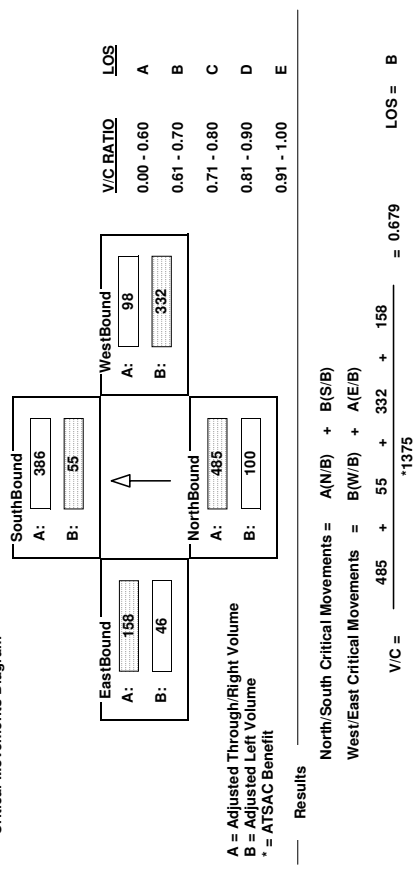

CalcaDB

INTERSECTION DATA SUMMARY SHEET

N/S: W/E: I/S No:
 AM/PM: Comments:
 COUNT DATE: STUDY DATE: GROWTH FACTOR:

Volume/Lane/Signal Configurations

	NORTHBOUND			SOUTHBOUND			WESTBOUND			EASTBOUND		
	LT	TH	RT	LT	TH	RT	LT	TH	RT	LT	TH	RT
EXISTING	42	2023	15	65	1225	155	28	94	244	594	42	54
AMBIENT												
RELATED												
PROJECT												
TOTAL	42	2023	15	65	1225	155	28	94	244	594	42	54

LANE	1	2	3	4	5	6	7	8	9	10	11	12
1	1	1	1	1	1	1	1	1	1	1	1	1
2												
3												
4												
5												
6												
7												
8												
9												
10												
11												
12												

Critical Movements Diagram

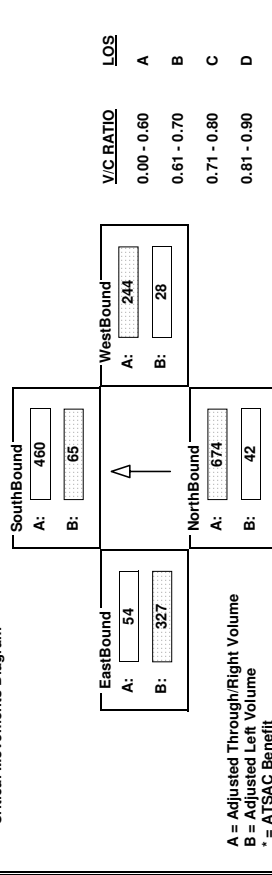

A = Adjusted Through/Right Volume
 B = Adjusted Left Volume
 * = ATSSAC Benefit

Results
 North/South Critical Movements = A(N/B) + B(S/B)
 West/East Critical Movements = A(W/B) + B(E/B)
 V/C = $\frac{674 + 65 + 244 + 327}{1425} = 0.849$ LOS = D

CalcaDB

INTERSECTION DATA SUMMARY SHEET

N/S: W/E: I/S No:
 AM/PM: Comments:
 COUNT DATE: STUDY DATE: GROWTH FACTOR:

Volume/Lane/Signal Configurations

	NORTHBOUND			SOUTHBOUND			WESTBOUND			EASTBOUND		
	LT	TH	RT	LT	TH	RT	LT	TH	RT	LT	TH	RT
EXISTING	0	918	116	159	436	0	862	0	73	0	0	0
AMBIENT												
RELATED												
PROJECT												
TOTAL	0	918	116	159	436	0	862	0	73	0	0	0

LANE	1	2	3	4	5	6	7	8	9	10	11	12
1	1	1	1	1	1	1	1	1	1	1	1	1
2												
3												
4												
5												
6												
7												
8												
9												
10												
11												
12												

Critical Movements Diagram

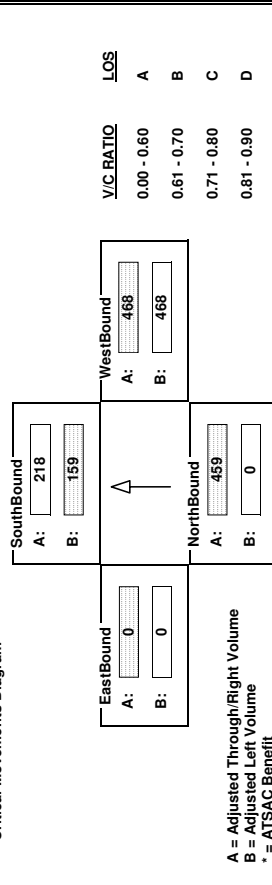

A = Adjusted Through/Right Volume
 B = Adjusted Left Volume
 * = ATSSAC Benefit

Results
 North/South Critical Movements = A(N/B) + B(S/B)
 West/East Critical Movements = A(W/B) + B(E/B)
 V/C = $\frac{459 + 159 + 468 + 0}{1375} = 0.720$ LOS = C

CalcaDB

INTERSECTION DATA SUMMARY SHEET

N/S: W/E: I/S No:

AM/PM: Comments:

COUNT DATE: STUDY DATE: GROWTH FACTOR:

Volume/Lane/Signal Configurations

	NORTHBOUND			SOUTHBOUND			WESTBOUND			EASTBOUND		
	LT	TH	RT	LT	TH	RT	LT	TH	RT	LT	TH	RT
EXISTING	233	425	119	122	323	129	89	466	61	96	406	169
AMBIENT												
RELATED												
PROJECT												
TOTAL	233	425	119	122	323	129	89	466	61	96	406	169

LANE: 1 2 1 1 1 1 1 1 1 1 1 1 1

SIGNAL:

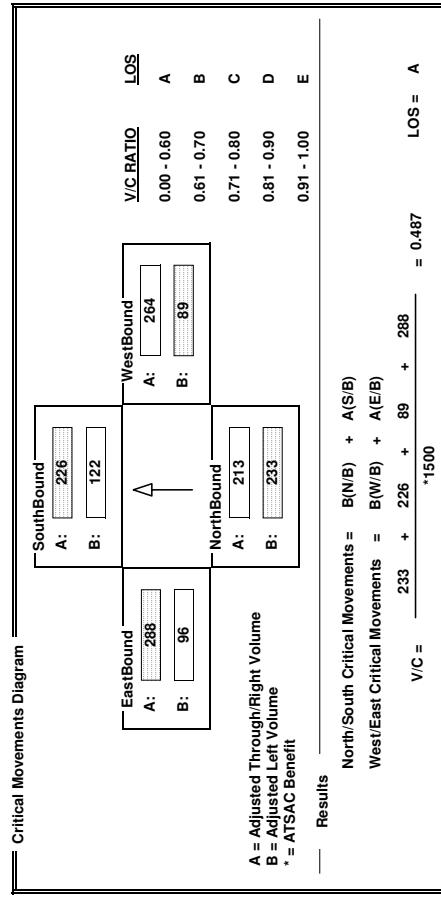

CalcaDB

INTERSECTION DATA SUMMARY SHEET

N/S: W/E: I/S No:

AM/PM: Comments:

COUNT DATE: STUDY DATE: GROWTH FACTOR:

Volume/Lane/Signal Configurations

	NORTHBOUND			SOUTHBOUND			WESTBOUND			EASTBOUND		
	LT	TH	RT	LT	TH	RT	LT	TH	RT	LT	TH	RT
EXISTING	109	726	256	67	597	26	129	851	58	23	1051	73
AMBIENT												
RELATED												
PROJECT												
TOTAL	109	726	256	67	597	26	129	851	58	23	1051	73

LANE: 1 2 1 1 1 1 1 1 1 1 1 1 1

SIGNAL:

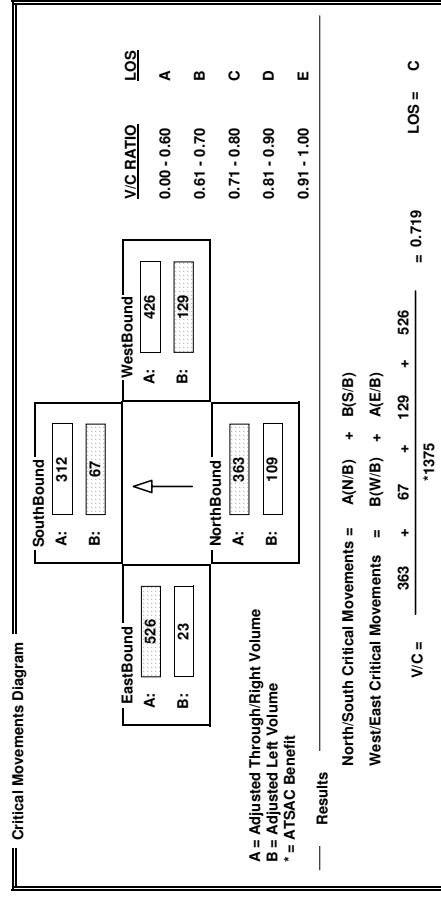

CalcaDB

INTERSECTION DATA SUMMARY SHEET

N/S: W/E: I/S No:
 AM/PM: Comments:
 COUNT DATE: STUDY DATE: GROWTH FACTOR:

Volume/Lane/Signal Configurations

	NORTHBOUND			SOUTHBOUND			WESTBOUND			EASTBOUND		
	LT	TH	RT	LT	TH	RT	LT	TH	RT	LT	TH	RT
EXISTING	166	1335	811	394	1708	72	185	310	295	281	279	158
AMBIENT												
RELATED												
PROJECT												
TOTAL	166	1335	811	394	1708	72	185	310	295	281	279	158
LANE	1	3	1	2	3	1	2	2	2	2	3	1
SIGNAL	Prot-Fix Auto			Prot-Fix Auto			Prot-Fix OLA			Prot-Fix Auto		

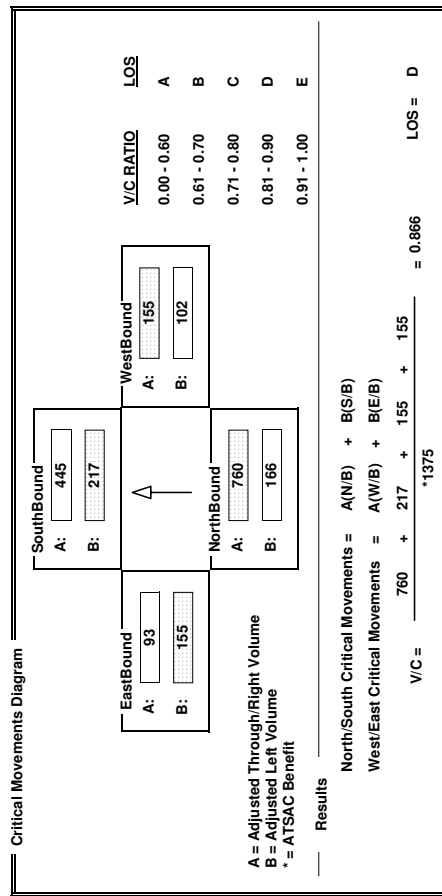

CalcaDB

INTERSECTION DATA SUMMARY SHEET

N/S: W/E: I/S No:
 AM/PM: Comments:
 COUNT DATE: STUDY DATE: GROWTH FACTOR:

Volume/Lane/Signal Configurations

	NORTHBOUND			SOUTHBOUND			WESTBOUND			EASTBOUND		
	LT	TH	RT	LT	TH	RT	LT	TH	RT	LT	TH	RT
EXISTING	106	1243	284	103	1179	48	333	214	89	78	258	69
AMBIENT												
RELATED												
PROJECT												
TOTAL	106	1243	284	103	1179	48	333	214	89	78	258	69
LANE	1	3	1	1	3	1	1	2	1	1	2	1
SIGNAL	Prot-Fix OLA			Prot-Fix OLA			Perm Auto			Prot-Fix OLA		

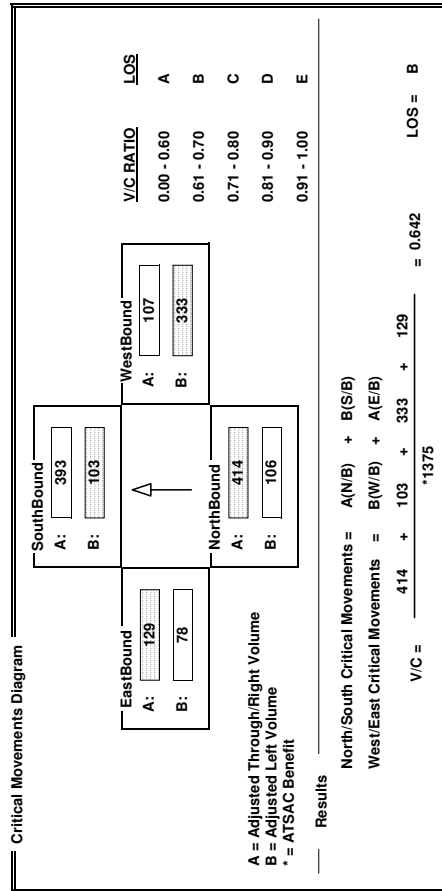

CalcaDB

INTERSECTION DATA SUMMARY SHEET

N/S: W/E: I/S No:
 AM/PM: Comments:
 COUNT DATE: STUDY DATE: GROWTH FACTOR:

Volume/Lane/Signal Configurations

	NORTHBOUND			SOUTHBOUND			WESTBOUND			EASTBOUND		
	LT	TH	RT	LT	TH	RT	LT	TH	RT	LT	TH	RT
EXISTING	53	1481	35	78	1506	237	35	63	82	255	50	57
AMBIENT												
RELATED												
PROJECT												
TOTAL	53	1481	35	78	1506	237	35	63	82	255	50	57

LANE:

SIGNAL:

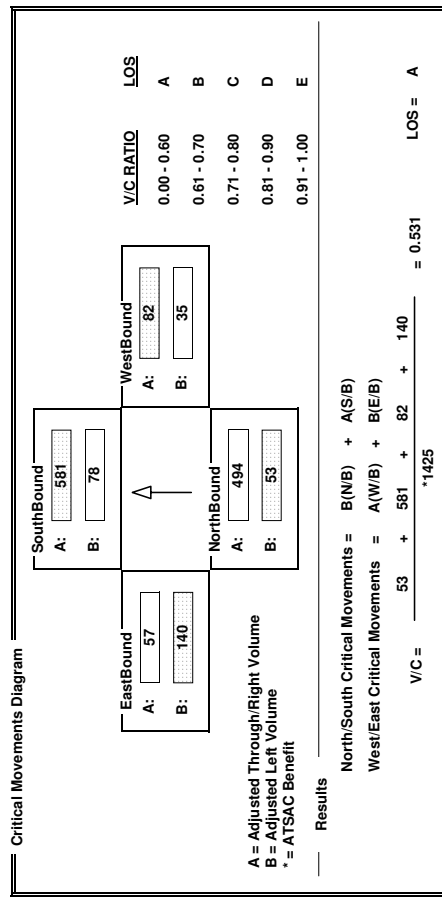

CalcaDB

INTERSECTION DATA SUMMARY SHEET

N/S: W/E: I/S No:
 AM/PM: Comments:
 COUNT DATE: STUDY DATE: GROWTH FACTOR:

Volume/Lane/Signal Configurations

	NORTHBOUND			SOUTHBOUND			WESTBOUND			EASTBOUND		
	LT	TH	RT	LT	TH	RT	LT	TH	RT	LT	TH	RT
EXISTING	0	521	144	144	617	0	893	0	78	0	0	0
AMBIENT												
RELATED												
PROJECT												
TOTAL	0	521	144	144	617	0	893	0	78	0	0	0

LANE:

SIGNAL:

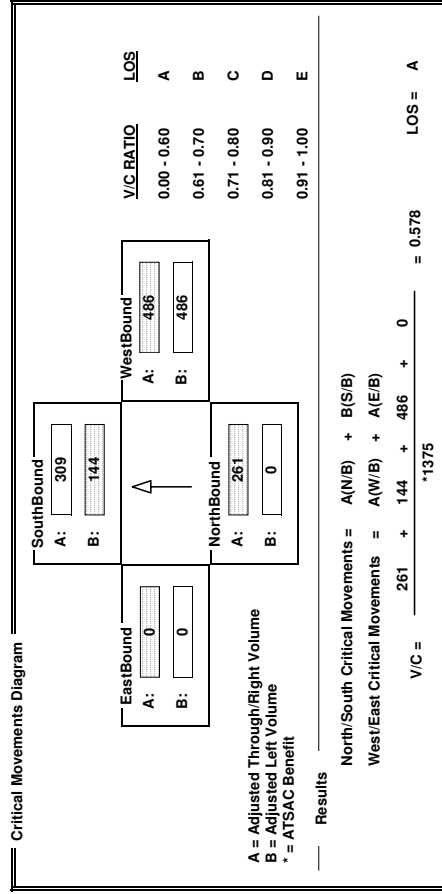

INTERSECTION DATA SUMMARY SHEET

N/S: W/E: I/S No:
 AM/PM: Comments:
 COUNT DATE: STUDY DATE: GROWTH FACTOR:

Volume/Lane/Signal Configurations

	NORTHBOUND			SOUTHBOUND			WESTBOUND			EASTBOUND		
	LT	TH	RT	LT	TH	RT	LT	TH	RT	LT	TH	RT
EXISTING	189	786	293	297	344	126	205	853	170	119	1263	245
AMBIENT												
RELATED												
PROJECT												
TOTAL	189	786	293	297	344	126	205	853	170	119	1263	245
LANE	1	2	1	1	1	1	1	2	1	1	2	1
SIGNAL	Prot-Fix			Auto			Auto			Auto		

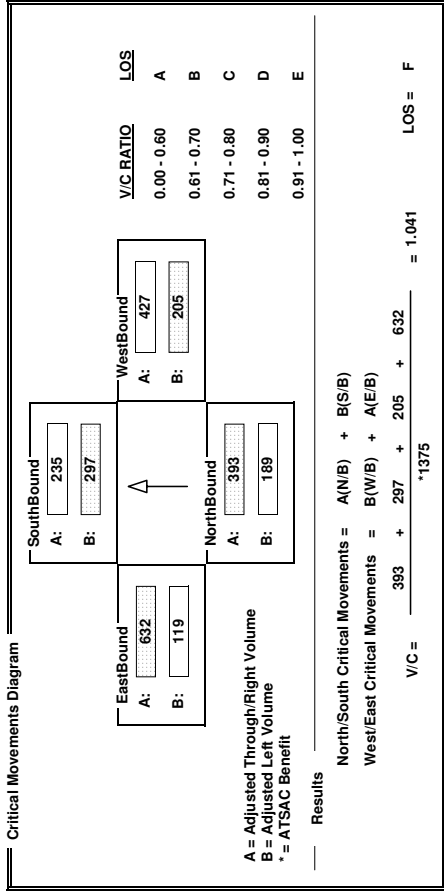

INTERSECTION DATA SUMMARY SHEET

N/S: W/E: I/S No:
 AM/PM: Comments:
 COUNT DATE: STUDY DATE: GROWTH FACTOR:

Volume/Lane/Signal Configurations

	NORTHBOUND			SOUTHBOUND			WESTBOUND			EASTBOUND		
	LT	TH	RT	LT	TH	RT	LT	TH	RT	LT	TH	RT
EXISTING	226	669	126	87	427	114	97	436	59	136	935	317
AMBIENT												
RELATED												
PROJECT												
TOTAL	226	669	126	87	427	114	97	436	59	136	935	317
LANE	1	2	1	1	1	1	1	1	1	1	1	1
SIGNAL	Perm			Auto			Auto			Perm		

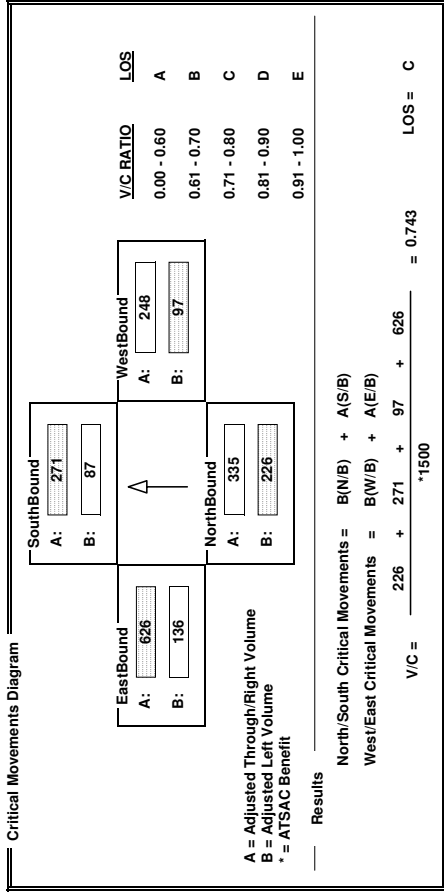

CalcaDB

INTERSECTION DATA SUMMARY SHEET

N/S: Sepulveda Blvd W/E: Imperial Hwy I/S No: 71
 AM/PM: **PM** Comments: MAP 2 Future 2013 with Project
 COUNT DATE: STUDY DATE: GROWTH FACTOR:

Volume/Lane/Signal Configurations

	NORTHBOUND			SOUTHBOUND			WESTBOUND			EASTBOUND		
	LT	TH	RT	LT	TH	RT	LT	TH	RT	LT	TH	RT
EXISTING	176	1626	1180	364	2313	118	239	333	362	177	308	166
AMBIENT												
RELATED												
PROJECT												
TOTAL	176	1626	1180	364	2313	118	239	333	362	177	308	166

LANE	1	2	3	1	2	3	1	2	3	1	2	3
<input type="checkbox"/> <input type="checkbox"/> <input type="checkbox"/> <input type="checkbox"/> <input type="checkbox"/> <input type="checkbox"/> <input type="checkbox"/> <input type="checkbox"/> <input type="checkbox"/> <input type="checkbox"/> <input type="checkbox"/> <input type="checkbox"/> <input type="checkbox"/>	1	3		1	3		2	3		2	3	

SIGNAL	Prot-Fix	Auto	RTOR	Phasing	RTOR	Phasing	RTOR	Prot-Fix	Auto	OLA
	Prot-Fix	Auto	RTOR	Phasing	RTOR	Phasing	RTOR	Prot-Fix	Auto	OLA

Critical Movements Diagram

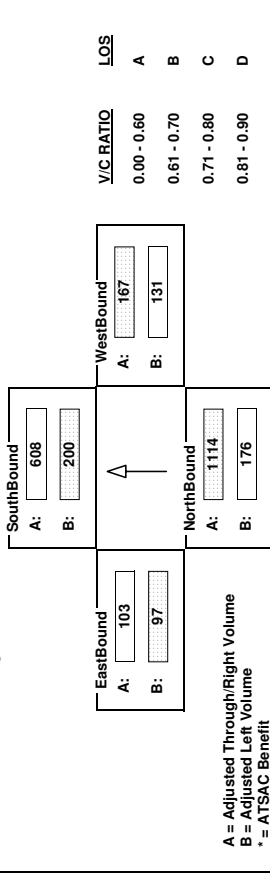

A = Adjusted Through/Right Volume
 B = Adjusted Left Volume
 * = ATSAC Benefit

Results
 North/South Critical Movements = A(N/B) + B(S/B)
 West/East Critical Movements = A(W/B) + B(E/B)
 V/C = $\frac{1114 + 200 + 167 + 97}{1375} = 1.078$ LOS = F

CalcaDB

INTERSECTION DATA SUMMARY SHEET

N/S: Sepulveda Blvd W/E: La Tijera Blvd I/S No: 101
 AM/PM: **PM** Comments: MAP 2 Future 2013 with Project
 COUNT DATE: STUDY DATE: GROWTH FACTOR:

Volume/Lane/Signal Configurations

	NORTHBOUND			SOUTHBOUND			WESTBOUND			EASTBOUND		
	LT	TH	RT	LT	TH	RT	LT	TH	RT	LT	TH	RT
EXISTING	164	1601	166	82	1254	83	297	386	59	88	444	82
AMBIENT												
RELATED												
PROJECT												
TOTAL	164	1601	166	82	1254	83	297	386	59	88	444	82

LANE	1	2	3	1	2	3	1	2	3	1	2	3
<input type="checkbox"/> <input type="checkbox"/> <input type="checkbox"/> <input type="checkbox"/> <input type="checkbox"/> <input type="checkbox"/> <input type="checkbox"/> <input type="checkbox"/> <input type="checkbox"/> <input type="checkbox"/> <input type="checkbox"/> <input type="checkbox"/> <input type="checkbox"/>	1	3		1	3		1	2		1	2	

SIGNAL	Prot-Fix	Auto	OLA	RTOR	Phasing	RTOR	Phasing	RTOR	Prot-Fix	Auto	OLA
	Prot-Fix	Auto	OLA	RTOR	Phasing	RTOR	Phasing	RTOR	Prot-Fix	Auto	OLA

Critical Movements Diagram

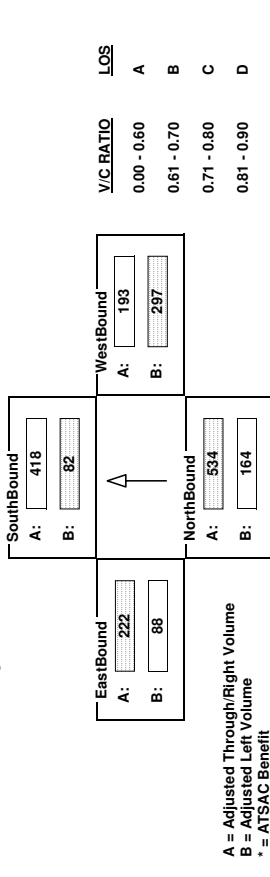

A = Adjusted Through/Right Volume
 B = Adjusted Left Volume
 * = ATSAC Benefit

Results
 North/South Critical Movements = A(N/B) + B(S/B)
 West/East Critical Movements = B(W/B) + A(E/B)
 V/C = $\frac{534 + 82 + 297 + 222}{1375} = 0.755$ LOS = C

CalcaDB

INTERSECTION DATA SUMMARY SHEET

N/S: W/E: I/S No:
 AM/PM: Comments:
 COUNT DATE: STUDY DATE: GROWTH FACTOR:

Volume/Lane/Signal Configurations

	NORTHBOUND			SOUTHBOUND			WESTBOUND			EASTBOUND		
	LT	TH	RT	LT	TH	RT	LT	TH	RT	LT	TH	RT
EXISTING	45	1883	33	125	2042	346	37	86	87	258	74	76
AMBIENT												
RELATED												
PROJECT												
TOTAL	45	1883	33	125	2042	346	37	86	87	258	74	76
LANE	1	3	1	1	2	1	1	1	1	2	1	1
SIGNAL	Phasing RTOR Auto			Phasing RTOR Auto			Phasing RTOR Auto			Phasing RTOR Auto		

Critical Movements Diagram

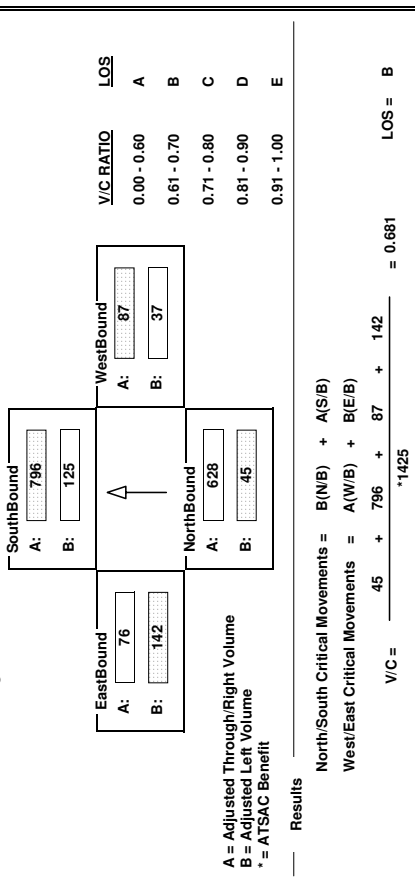

CalcaDB

INTERSECTION DATA SUMMARY SHEET

N/S: W/E: I/S No:
 AM/PM: Comments:
 COUNT DATE: STUDY DATE: GROWTH FACTOR:

Volume/Lane/Signal Configurations

	NORTHBOUND			SOUTHBOUND			WESTBOUND			EASTBOUND		
	LT	TH	RT	LT	TH	RT	LT	TH	RT	LT	TH	RT
EXISTING	0	632	83	216	810	0	762	0	174	0	0	0
AMBIENT												
RELATED												
PROJECT												
TOTAL	0	632	83	216	810	0	762	0	174	0	0	0
LANE	1	1	1	1	2	1	1	1	1	1	1	1
SIGNAL	Phasing RTOR OLA			Phasing RTOR Auto			Phasing RTOR Auto			Phasing RTOR Auto		

Critical Movements Diagram

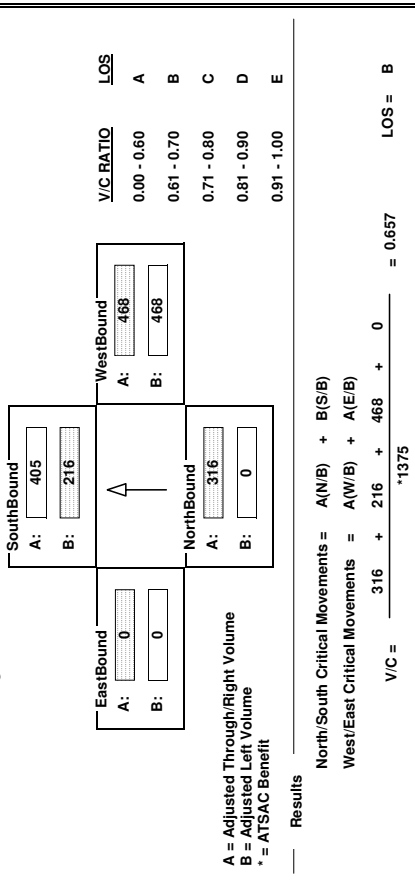

CalcaDB

INTERSECTION DATA SUMMARY SHEET

N/S: W/E: I/S No:

AM/PM: Comments:

COUNT DATE: STUDY DATE: GROWTH FACTOR:

Volume/Lane/Signal Configurations

	NORTHBOUND		SOUTHBOUND		WESTBOUND		EASTBOUND					
	LT	TH	LT	TH	LT	TH	LT	TH				
EXISTING	256	534	139	64	445	120	67	826	98	96	236	156
AMBIENT												
RELATED												
PROJECT												
TOTAL	256	534	139	64	445	120	67	826	98	96	236	156

LANE: 1 2 1 1 1 1 1 1 1 1 1 1 1

Phasing: RTOR Auto Auto Auto Auto RTOR RTOR RTOR RTOR

SIGNAL: Perm Perm Auto Auto Auto Perm Perm Auto Auto

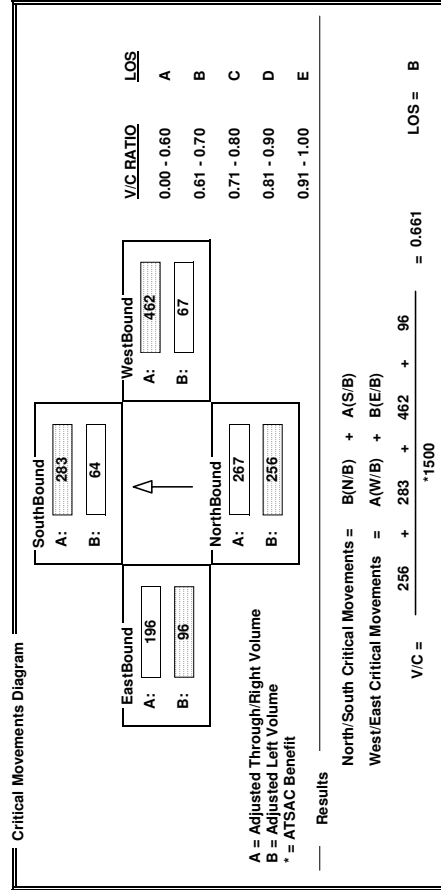

CalcaDB

INTERSECTION DATA SUMMARY SHEET

N/S: W/E: I/S No:

AM/PM: Comments:

COUNT DATE: STUDY DATE: GROWTH FACTOR:

Volume/Lane/Signal Configurations

	NORTHBOUND		SOUTHBOUND		WESTBOUND		EASTBOUND					
	LT	TH	LT	TH	LT	TH	LT	TH				
EXISTING	118	617	84	72	698	28	133	1191	207	27	609	74
AMBIENT												
RELATED												
PROJECT												
TOTAL	118	617	84	72	698	28	133	1191	207	27	609	74

LANE: 1 2 1 1 1 1 1 1 1 1 1 1 1

Phasing: RTOR Auto Auto Auto Auto RTOR RTOR RTOR RTOR

SIGNAL: Prot-Fix Prot-Fix Auto Auto Auto Prot-Fix Auto Auto

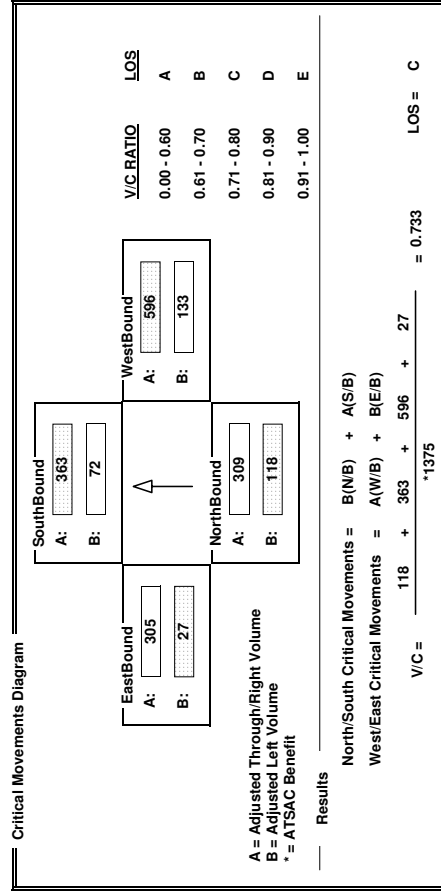

INTERSECTION DATA SUMMARY SHEET

N/S: Sepulveda Blvd W/E: Imperial Hwy I/S No: 71
 AM/PM: AM Comments: MAP 3 Future 2013 w/o Project
 COUNT DATE: STUDY DATE: GROWTH FACTOR:

Volume/Lane/Signal Configurations

	NORTHBOUND			SOUTHBOUND			WESTBOUND			EASTBOUND		
	LT	TH	RT	LT	TH	RT	LT	TH	RT	LT	TH	RT
EXISTING	137	1666	705	277	2083	250	198	328	304	218	275	202
AMBIENT												
RELATED												
PROJECT												
TOTAL	137	1666	705	277	2083	250	198	328	304	218	275	202

LANE: 1 3 1 2 3 1 2 2 2 2 2 3 1

SIGNAL: Prot-Fix RTOR Phasing RTOR Prot-Fix RTOR Prot-Fix RTOR

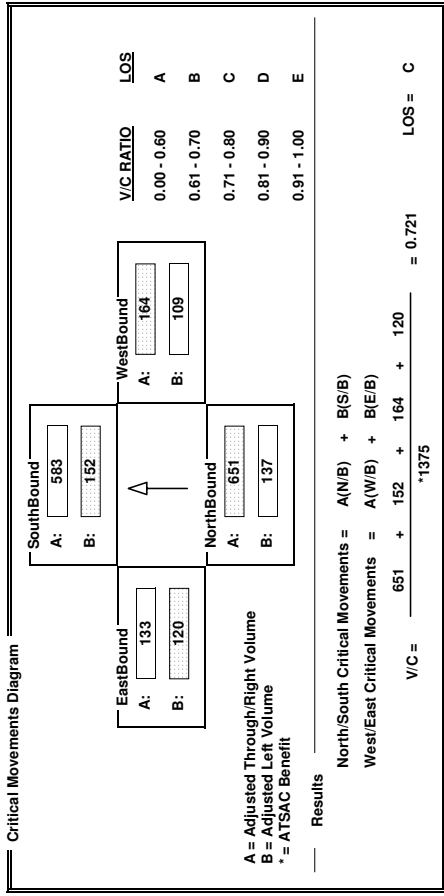

INTERSECTION DATA SUMMARY SHEET

N/S: Sepulveda Blvd W/E: La Tijera Blvd I/S No: 101
 AM/PM: AM Comments: MAP 3 Future 2013 w/o Project
 COUNT DATE: STUDY DATE: GROWTH FACTOR:

Volume/Lane/Signal Configurations

	NORTHBOUND			SOUTHBOUND			WESTBOUND			EASTBOUND		
	LT	TH	RT	LT	TH	RT	LT	TH	RT	LT	TH	RT
EXISTING	104	1380	130	60	1086	58	368	197	37	47	317	79
AMBIENT												
RELATED												
PROJECT												
TOTAL	104	1380	130	60	1086	58	368	197	37	47	317	79

LANE: 1 3 1 1 3 1 1 1 2 1 1 2 1

SIGNAL: Prot-Fix RTOR Phasing RTOR Prot-Fix RTOR Prot-Fix RTOR

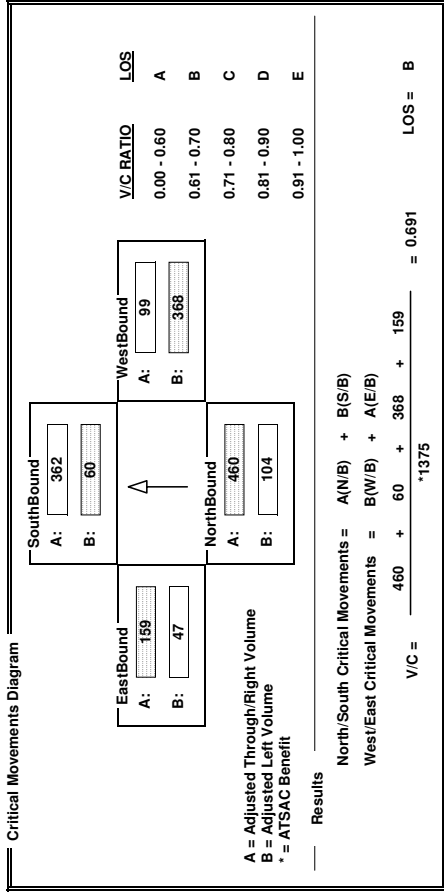

CalcaDB

INTERSECTION DATA SUMMARY SHEET

N/S: W/E: I/S No:

AM/PM: Comments: GROWTH FACTOR:

COUNT DATE: STUDY DATE:

Volume/Lane/Signal Configurations

	NORTHBOUND			SOUTHBOUND			WESTBOUND			EASTBOUND		
	LT	TH	RT	LT	TH	RT	LT	TH	RT	LT	TH	RT
EXISTING	0	921	118	160	426	0	874	0	72	0	0	0
AMBIENT												
RELATED												
PROJECT												
TOTAL	0	921	118	160	426	0	874	0	72	0	0	0

LANE:

Signal:

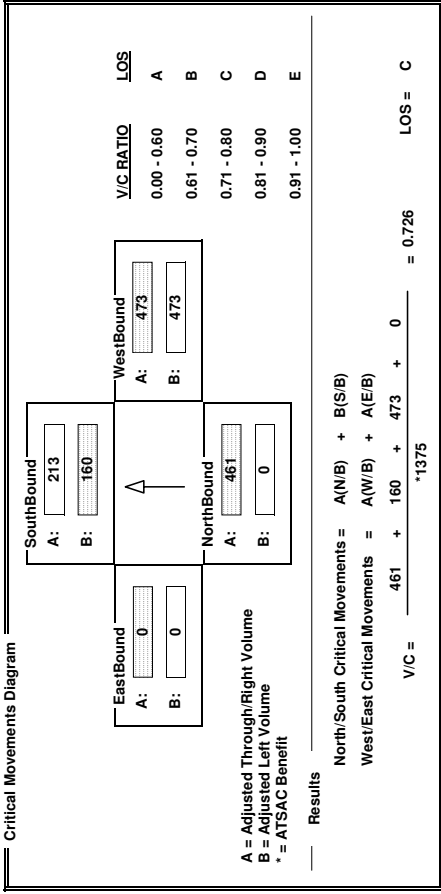

CalcaDB

INTERSECTION DATA SUMMARY SHEET

N/S: W/E: I/S No:

AM/PM: Comments: GROWTH FACTOR:

COUNT DATE: STUDY DATE:

Volume/Lane/Signal Configurations

	NORTHBOUND			SOUTHBOUND			WESTBOUND			EASTBOUND		
	LT	TH	RT	LT	TH	RT	LT	TH	RT	LT	TH	RT
EXISTING	45	1949	16	77	1199	173	28	109	246	596	45	56
AMBIENT												
RELATED												
PROJECT												
TOTAL	45	1949	16	77	1199	173	28	109	246	596	45	56

LANE:

Signal:

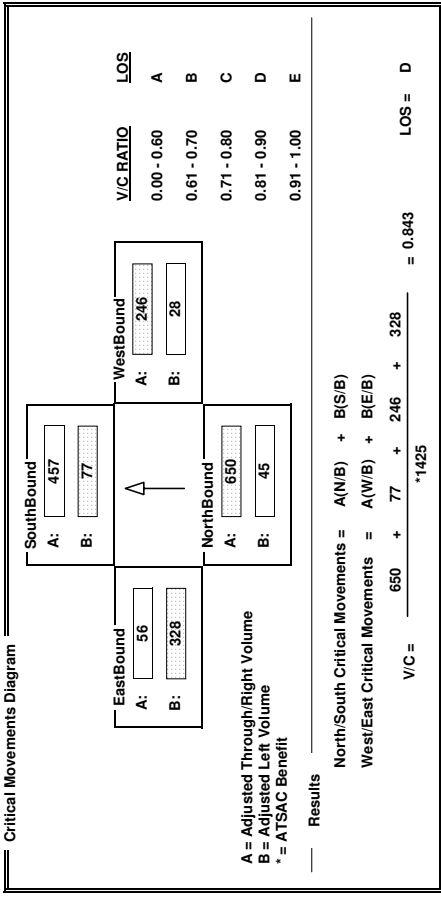

CalcaDB

INTERSECTION DATA SUMMARY SHEET

N/S: W/E: I/S No:

AM/PM: Comments:

COUNT DATE: STUDY DATE: GROWTH FACTOR:

Volume/Lane/Signal Configurations

	NORTHBOUND			SOUTHBOUND			WESTBOUND			EASTBOUND		
	LT	TH	RT	LT	TH	RT	LT	TH	RT	LT	TH	RT
EXISTING	113	699	284	68	591	28	130	840	58			66
AMBIENT												
RELATED												
PROJECT												
TOTAL	113	699	284	68	591	28	130	840	58			66

LANE: 1 2 1 1 1 1 1 2 1 1 2 1 1

SIGNAL: Prot-Fix RTOR Auto Prot-Fix Auto Prot-Fix Auto Prot-Fix Auto

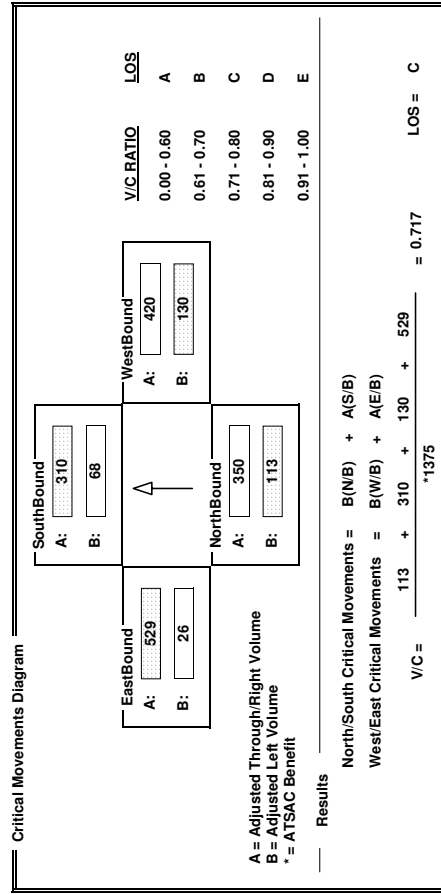

CalcaDB

INTERSECTION DATA SUMMARY SHEET

N/S: W/E: I/S No:

AM/PM: Comments:

COUNT DATE: STUDY DATE: GROWTH FACTOR:

Volume/Lane/Signal Configurations

	NORTHBOUND			SOUTHBOUND			WESTBOUND			EASTBOUND		
	LT	TH	RT	LT	TH	RT	LT	TH	RT	LT	TH	RT
EXISTING	226	444	119	135	319	124	90	480	67	97	419	169
AMBIENT												
RELATED												
PROJECT												
TOTAL	226	444	119	135	319	124	90	480	67	97	419	169

LANE: 1 2 1 1 1 1 1 1 1 1 1 1 1

SIGNAL: Perm RTOR Auto Perm Auto Perm Auto Perm Auto

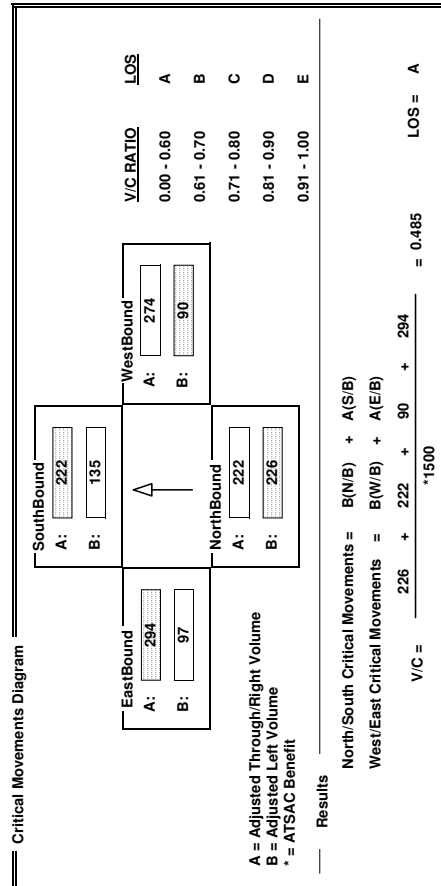

CalcaDB

INTERSECTION DATA SUMMARY SHEET

N/S: Sepulveda Blvd W/E: Imperial Hwy I/S No: 71
 AM/PM: **MD** Comments: MAP 3 Future 2013 w/o Project
 COUNT DATE: STUDY DATE: GROWTH FACTOR:

Volume/Lane/Signal Configurations

	NORTHBOUND			SOUTHBOUND			WESTBOUND			EASTBOUND		
	LT	TH	RT	LT	TH	RT	LT	TH	RT	LT	TH	RT
EXISTING	167	1279	842	438	1728	78	187	314	278	330	280	156
AMBIENT												
RELATED												
PROJECT												
TOTAL	167	1279	842	438	1728	78	187	314	278	330	280	156

LANE	1	2	3	1	2	3	1	2	3	1	2	3
PHASING	↓	↓	↓	↓	↓	↓	↓	↓	↓	↓	↓	↓
RTOR	RTOR	RTOR	RTOR	RTOR	RTOR	RTOR	RTOR	RTOR	RTOR	RTOR	RTOR	RTOR
SIGNAL	Prot-Fix	Auto	Auto	Prot-Fix	Auto	Auto	Prot-Fix	OLA	OLA	Prot-Fix	Auto	Auto

Critical Movements Diagram

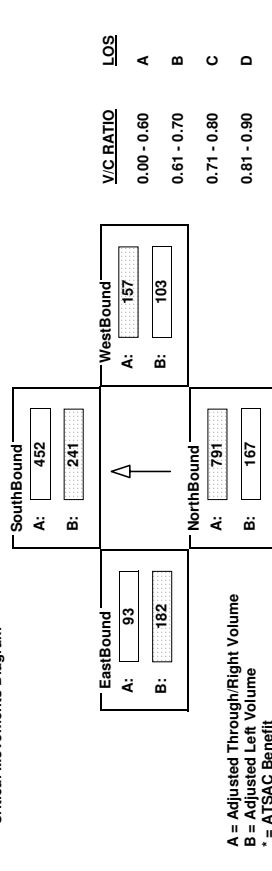

A = Adjusted Through/Right Volume
 B = Adjusted Left Volume
 * = ATSAC Benefit

Results
 North/South Critical Movements = A(N/B) + B(S/B)
 West/East Critical Movements = A(W/B) + B(E/B)
 V/C = $\frac{791 + 241 + 157 + 182}{1375} = 0.927$ LOS = E

CalcaDB

INTERSECTION DATA SUMMARY SHEET

N/S: Sepulveda Blvd W/E: La Tijera Blvd I/S No: 101
 AM/PM: **MD** Comments: MAP 3 Future 2013 w/o Project
 COUNT DATE: STUDY DATE: GROWTH FACTOR:

Volume/Lane/Signal Configurations

	NORTHBOUND			SOUTHBOUND			WESTBOUND			EASTBOUND		
	LT	TH	RT	LT	TH	RT	LT	TH	RT	LT	TH	RT
EXISTING	108	1204	328	126	1145	49	284	216	100	79	259	69
AMBIENT												
RELATED												
PROJECT												
TOTAL	108	1204	328	126	1145	49	284	216	100	79	259	69

LANE	1	2	3	1	2	3	1	2	3	1	2	3
PHASING	↓	↓	↓	↓	↓	↓	↓	↓	↓	↓	↓	↓
RTOR	RTOR	RTOR	RTOR	RTOR	RTOR	RTOR	RTOR	RTOR	RTOR	RTOR	RTOR	RTOR
SIGNAL	Prot-Fix	OLA	OLA	Prot-Fix	OLA	OLA	Prot-Fix	Auto	Auto	Prot-Fix	OLA	OLA

Critical Movements Diagram

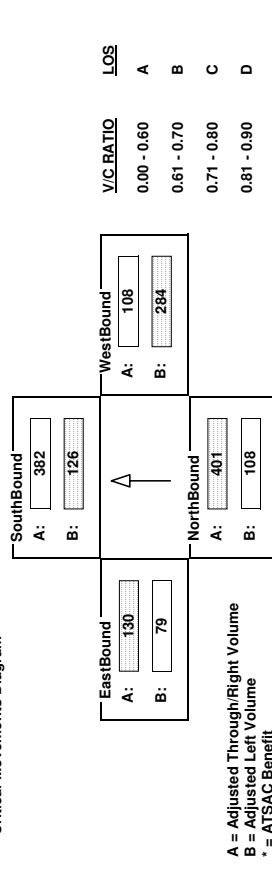

A = Adjusted Through/Right Volume
 B = Adjusted Left Volume
 * = ATSAC Benefit

Results
 North/South Critical Movements = A(N/B) + B(S/B)
 West/East Critical Movements = B(W/B) + A(E/B)
 V/C = $\frac{401 + 126 + 284 + 130}{1375} = 0.614$ LOS = B

CalcaDB

INTERSECTION DATA SUMMARY SHEET

N/S: W/E: I/S No:
 AM/PM: Comments:
 COUNT DATE: STUDY DATE: GROWTH FACTOR:

Volume/Lane/Signal Configurations

	NORTHBOUND			SOUTHBOUND			WESTBOUND			EASTBOUND		
	LT	TH	RT	LT	TH	RT	LT	TH	RT	LT	TH	RT
EXISTING	56	1448	37	79	1468	268	36	68	85	256	57	58
AMBIENT												
RELATED												
PROJECT												
TOTAL	56	1448	37	79	1468	268	36	68	85	256	57	58
LANE	1	3	1	1	2	1	1	1	1	2	1	1
SIGNAL	Phasing RTOR Auto			Phasing RTOR Perm Auto			Phasing RTOR Split Auto			Phasing RTOR Split Auto		

Critical Movements Diagram

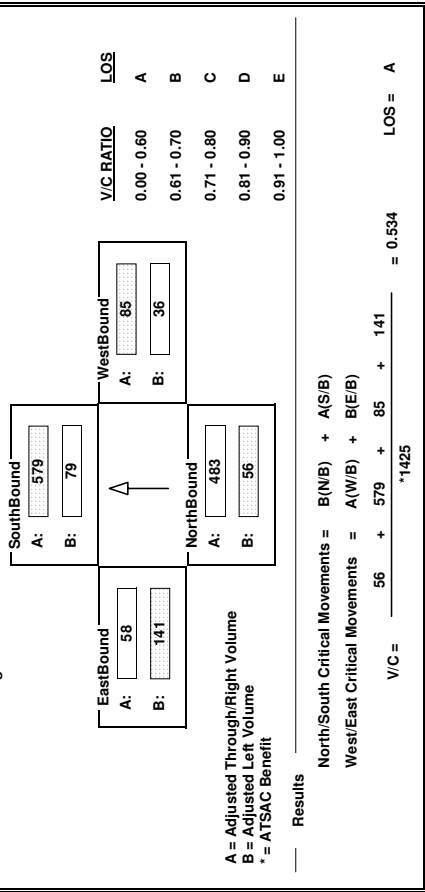

CalcaDB

INTERSECTION DATA SUMMARY SHEET

N/S: W/E: I/S No:
 AM/PM: Comments:
 COUNT DATE: STUDY DATE: GROWTH FACTOR:

Volume/Lane/Signal Configurations

	NORTHBOUND			SOUTHBOUND			WESTBOUND			EASTBOUND		
	LT	TH	RT	LT	TH	RT	LT	TH	RT	LT	TH	RT
EXISTING	0	506	146	146	629	0	896	0	76	0	0	0
AMBIENT												
RELATED												
PROJECT												
TOTAL	0	506	146	146	629	0	896	0	76	0	0	0
LANE	1	1	1	1	2	1	1	1	1	1	1	1
SIGNAL	Phasing RTOR OLA			Phasing RTOR Prot-Fix Auto			Phasing RTOR Split Auto			Phasing RTOR Split Auto		

Critical Movements Diagram

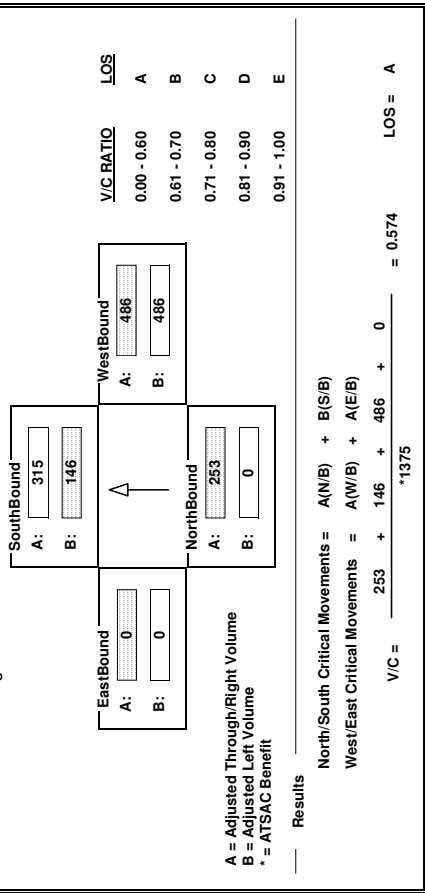

CalcaDB

INTERSECTION DATA SUMMARY SHEET

N/S: W/E: I/S No:

AM/PM: Comments:

COUNT DATE: STUDY DATE: GROWTH FACTOR:

Volume/Lane/Signal Configurations

	NORTHBOUND		SOUTHBOUND		WESTBOUND		EASTBOUND		
	LT	TH	LT	TH	LT	TH	LT	TH	
EXISTING	234	633	127	94	426	96	140	1012	318
AMBIENT									
RELATED									
PROJECT									
TOTAL	234	633	127	94	426	96	140	1012	318

LANE: 1 2 1 1 1 1 1 1 1 1

Signal Configurations: Phasing: RTOR, RTOR, RTOR, RTOR; RTOR: Auto, Auto, Perm, Perm; RTOR: Auto, Auto, Perm, Perm

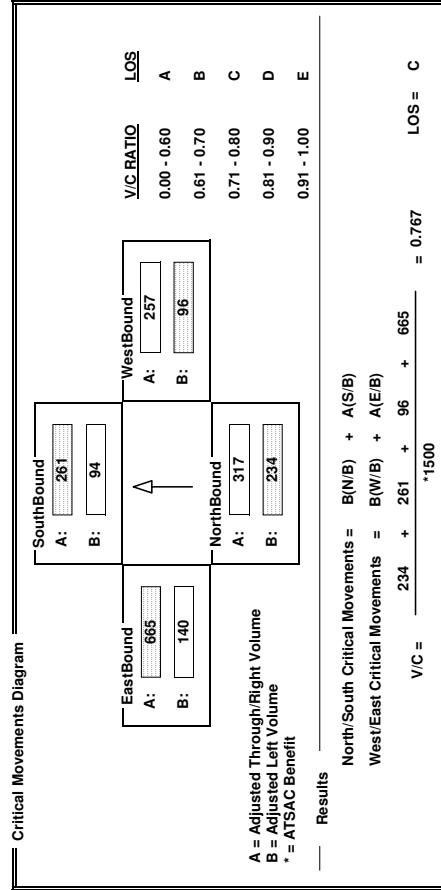

CalcaDB

INTERSECTION DATA SUMMARY SHEET

N/S: W/E: I/S No:

AM/PM: Comments:

COUNT DATE: STUDY DATE: GROWTH FACTOR:

Volume/Lane/Signal Configurations

	NORTHBOUND		SOUTHBOUND		WESTBOUND		EASTBOUND		
	LT	TH	LT	TH	LT	TH	LT	TH	
EXISTING	189	797	302	331	329	128	206	847	173
AMBIENT									
RELATED									
PROJECT									
TOTAL	189	797	302	331	329	128	206	847	173

LANE: 1 2 1 1 1 1 1 1 1 1

Signal Configurations: Phasing: RTOR, RTOR, RTOR, RTOR; RTOR: Auto, Auto, Prot-Fix, Prot-Fix

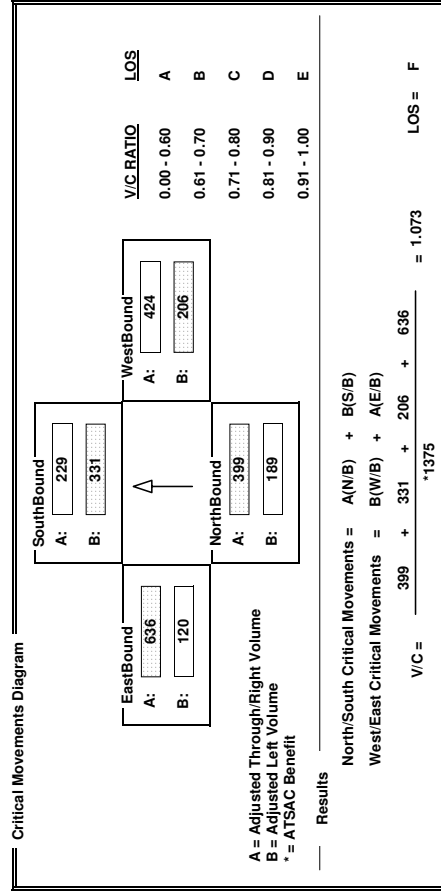

CalcaDB

INTERSECTION DATA SUMMARY SHEET

N/S: W/E: I/S No:
 AM/PM: Comments:
 COUNT DATE: STUDY DATE: GROWTH FACTOR:

Volume/Lane/Signal Configurations

	NORTHBOUND			SOUTHBOUND			WESTBOUND			EASTBOUND		
	LT	TH	RT	LT	TH	RT	LT	TH	RT	LT	TH	RT
EXISTING	177	1588	1187	375	2308	155	242	352	364	182	312	168
AMBIENT												
RELATED												
PROJECT												
TOTAL	177	1588	1187	375	2308	155	242	352	364	182	312	168

LANE: 1 3 1 2 3 1 2 2 2 2 2 3 1

SIGNAL: Prot-Fix RTOR Phasing RTOR Prot-Fix RTOR Prot-Fix RTOR
 Auto Auto OLA OLA

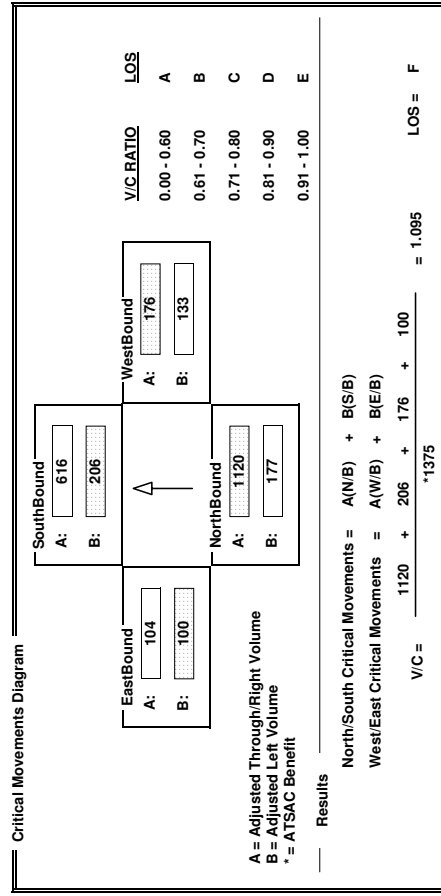

CalcaDB

INTERSECTION DATA SUMMARY SHEET

N/S: W/E: I/S No:
 AM/PM: Comments:
 COUNT DATE: STUDY DATE: GROWTH FACTOR:

Volume/Lane/Signal Configurations

	NORTHBOUND			SOUTHBOUND			WESTBOUND			EASTBOUND		
	LT	TH	RT	LT	TH	RT	LT	TH	RT	LT	TH	RT
EXISTING	176	1538	168	92	1196	86	290	387	59	89	446	88
AMBIENT												
RELATED												
PROJECT												
TOTAL	176	1538	168	92	1196	86	290	387	59	89	446	88

LANE: 1 3 1 1 3 1 1 1 2 1 1 2 1

SIGNAL: Prot-Fix RTOR Phasing RTOR Prot-Fix RTOR Prot-Fix RTOR
 OLA OLA Auto OLA

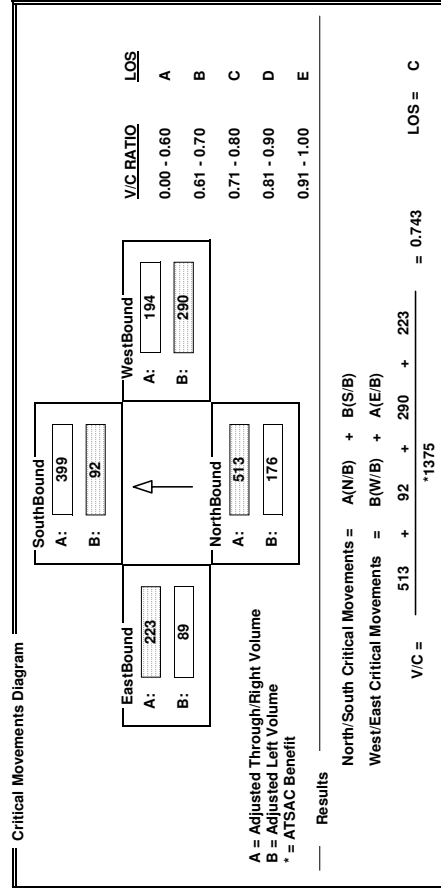

CalcaDB

INTERSECTION DATA SUMMARY SHEET

N/S: Sepulveda Blvd W/E: 76th St/77th St I/S No: 136
 AM/PM: **PM** Comments: MAP 3 Future 2013 w/o Project
 COUNT DATE: STUDY DATE: GROWTH FACTOR:

Volume/Lane/Signal Configurations

	NORTHBOUND			SOUTHBOUND			WESTBOUND			EASTBOUND		
	LT	TH	RT	LT	TH	RT	LT	TH	RT	LT	TH	RT
EXISTING	47	1828	29	126	1999	347	38	97	88	288	79	69
AMBIENT												
RELATED												
PROJECT												
TOTAL	47	1828	29	126	1999	347	38	97	88	288	79	69

LANE	1	2	3	4	5	6	7	8	9	10	11	12
1	1	1	1	1	1	1	1	1	1	1	1	1
2												
3												
4												
5												
6												
7												
8												
9												
10												
11												
12												

SIGNAL	Phasing	RTOR	Auto	Perm	RTOR	Auto	Perm	RTOR	Auto	Split	RTOR	Auto

Critical Movements Diagram

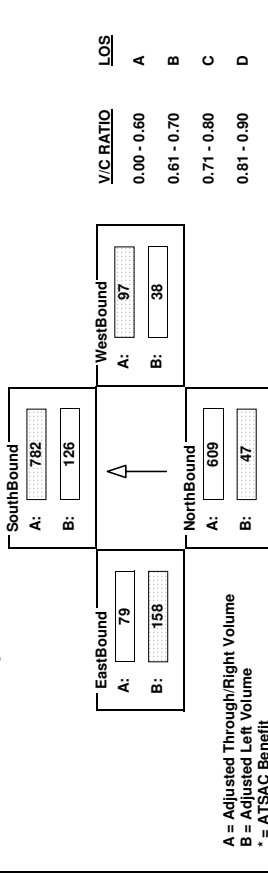

A = Adjusted Through/Right Volume
 B = Adjusted Left Volume
 * = ATSSAC Benefit

Results

North/South Critical Movements = B(N/B) + A(S/B)
 West/East Critical Movements = A(W/B) + B(E/B)

V/C = $\frac{47 + 782 + 97 + 158}{1425} = 0.691$ LOS = B

CalcaDB

INTERSECTION DATA SUMMARY SHEET

N/S: La Cienega Blvd W/E: I-405 SB Ramps n/o Century I/S No: 96
 AM/PM: **PM** Comments: MAP 3 Future 2013 w/o Project
 COUNT DATE: STUDY DATE: GROWTH FACTOR:

Volume/Lane/Signal Configurations

	NORTHBOUND			SOUTHBOUND			WESTBOUND			EASTBOUND		
	LT	TH	RT	LT	TH	RT	LT	TH	RT	LT	TH	RT
EXISTING	0	618	86	228	816	0	775	0	174	0	0	0
AMBIENT												
RELATED												
PROJECT												
TOTAL	0	618	86	228	816	0	775	0	174	0	0	0

LANE	1	2	3	4	5	6	7	8	9	10	11	12
1	1	1	1	1	1	1	1	1	1	1	1	1
2												
3												
4												
5												
6												
7												
8												
9												
10												
11												
12												

SIGNAL	Phasing	RTOR	OLA	Prot-Fix	Auto	Split	RTOR	Auto

Critical Movements Diagram

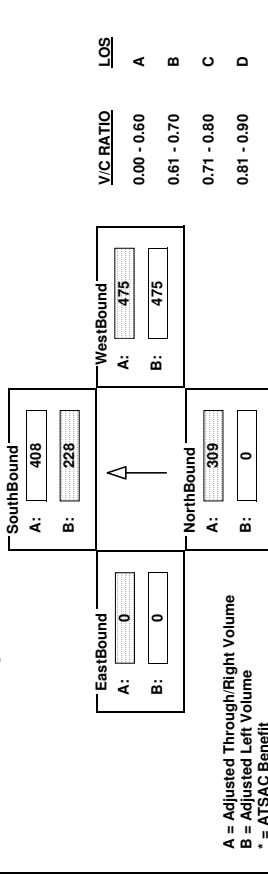

A = Adjusted Through/Right Volume
 B = Adjusted Left Volume
 * = ATSSAC Benefit

Results

North/South Critical Movements = A(N/B) + B(S/B)
 West/East Critical Movements = A(W/B) + A(E/B)

V/C = $\frac{309 + 228 + 475 + 0}{1375} = 0.666$ LOS = B

CalcaDB

INTERSECTION DATA SUMMARY SHEET

N/S: W/E: I/S No:

AM/PM: Comments:

COUNT DATE: STUDY DATE: GROWTH FACTOR:

Volume/Lane/Signal Configurations

	NORTHBOUND			SOUTHBOUND			WESTBOUND			EASTBOUND		
	LT	TH	RT	LT	TH	RT	LT	TH	RT	LT	TH	RT
EXISTING	118	659	90	78	722	28	139	1227	207			92
AMBIENT												
RELATED												
PROJECT												
TOTAL	118	659	90	78	722	28	139	1227	207			92

LANE:

SIGNAL:

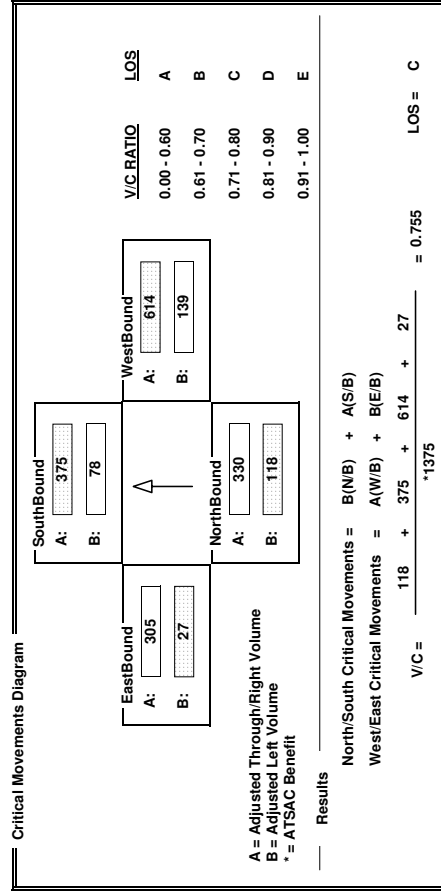

CalcaDB

INTERSECTION DATA SUMMARY SHEET

N/S: W/E: I/S No:

AM/PM: Comments:

COUNT DATE: STUDY DATE: GROWTH FACTOR:

Volume/Lane/Signal Configurations

	NORTHBOUND			SOUTHBOUND			WESTBOUND			EASTBOUND		
	LT	TH	RT	LT	TH	RT	LT	TH	RT	LT	TH	RT
EXISTING	256	570	139	64	451	126	67	874	98	102	254	156
AMBIENT												
RELATED												
PROJECT												
TOTAL	256	570	139	64	451	126	67	874	98	102	254	156

LANE:

SIGNAL:

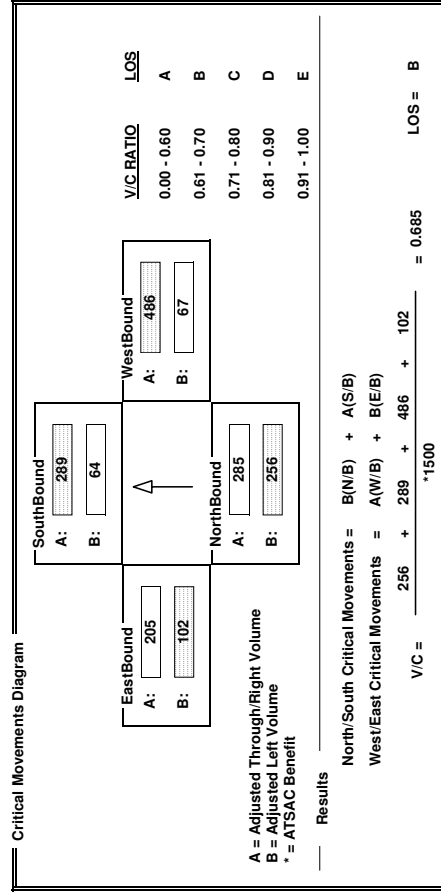

CalcaDB

INTERSECTION DATA SUMMARY SHEET

N/S: Sepulveda Blvd W/E: La Tijera Blvd I/S No: 101
 AM/PM: AM Comments: MAP 3 Future 2013 with Project
 COUNT DATE: STUDY DATE: GROWTH FACTOR:

Volume/Lane/Signal Configurations

	NORTHBOUND		SOUTHBOUND		WESTBOUND		EASTBOUND					
	LT	TH	LT	TH	LT	TH	LT	TH				
EXISTING	104	1500	142	60	1194	58	398	197	37	47	317	79
AMBIENT												
RELATED												
PROJECT												
TOTAL	104	1500	142	60	1194	58	398	197	37	47	317	79

LANE: 1 3 1 1 1 2 1 1 2 1 1 2 1 1

Signal: Prot-Fix OLA RTOR Phasing RTOR Phasing RTOR
 Prot-Fix OLA Auto Auto OLA

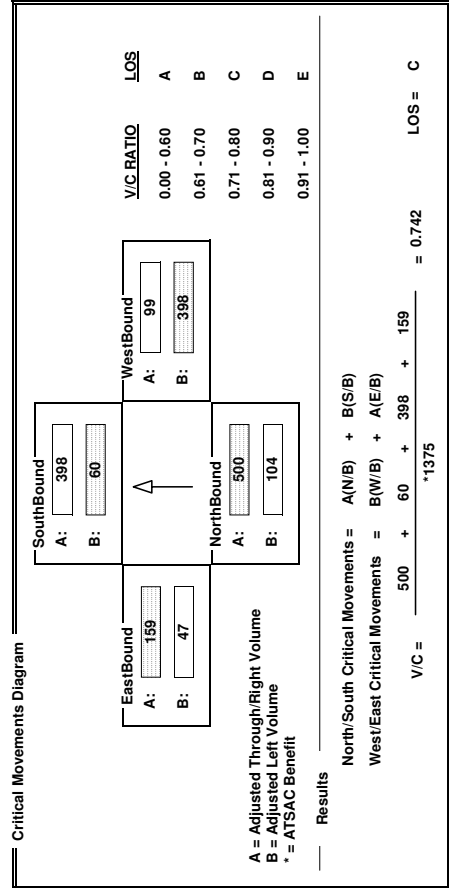

CalcaDB

INTERSECTION DATA SUMMARY SHEET

N/S: Sepulveda Blvd W/E: Imperial Hwy I/S No: 71
 AM/PM: AM Comments: MAP 3 Future 2013 with Project
 COUNT DATE: STUDY DATE: GROWTH FACTOR:

Volume/Lane/Signal Configurations

	NORTHBOUND		SOUTHBOUND		WESTBOUND		EASTBOUND					
	LT	TH	LT	TH	LT	TH	LT	TH				
EXISTING	137	1720	705	307	2113	250	198	328	328	224	281	202
AMBIENT												
RELATED												
PROJECT												
TOTAL	137	1720	705	307	2113	250	198	328	328	224	281	202

LANE: 1 3 1 1 1 2 1 1 2 1 1 2 1 1

Signal: Prot-Fix Auto RTOR Phasing RTOR Phasing RTOR
 Prot-Fix Auto Auto OLA

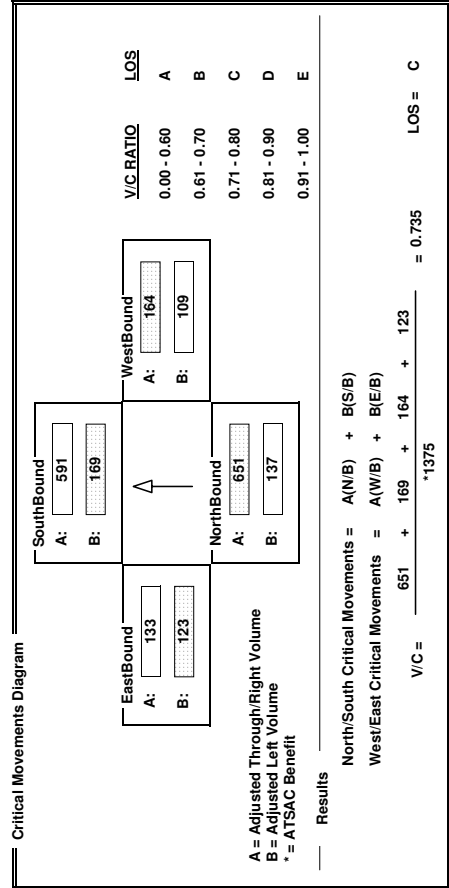

CalcaDB

INTERSECTION DATA SUMMARY SHEET

N/S: W/E: I/S No:
 AM/PM: Comments:
 COUNT DATE: STUDY DATE: GROWTH FACTOR:

Volume/Lane/Signal Configurations

	NORTHBOUND			SOUTHBOUND			WESTBOUND			EASTBOUND		
	LT	TH	RT	LT	TH	RT	LT	TH	RT	LT	TH	RT
EXISTING	45	2069	16	77	1247	173	28	109	246	596	45	56
AMBIENT												
RELATED												
PROJECT												
TOTAL	45	2069	16	77	1247	173	28	109	246	596	45	56

LANE:

Signal Configurations:

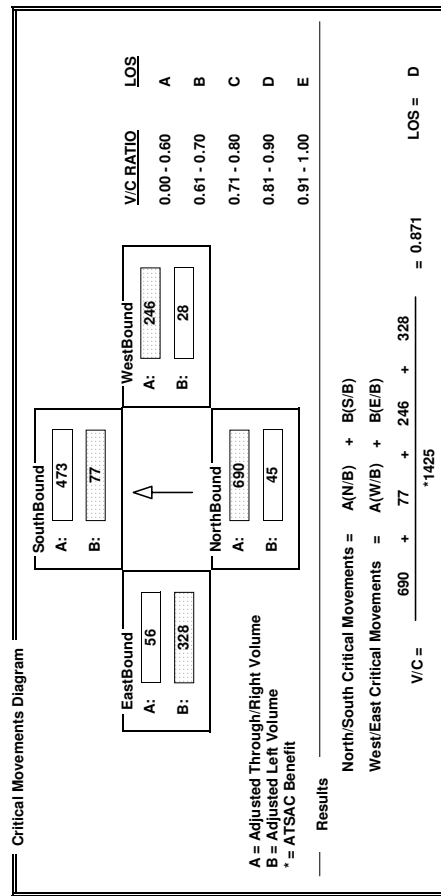

CalcaDB

INTERSECTION DATA SUMMARY SHEET

N/S: W/E: I/S No:
 AM/PM: Comments:
 COUNT DATE: STUDY DATE: GROWTH FACTOR:

Volume/Lane/Signal Configurations

	NORTHBOUND			SOUTHBOUND			WESTBOUND			EASTBOUND		
	LT	TH	RT	LT	TH	RT	LT	TH	RT	LT	TH	RT
EXISTING	0	945	118	160	444	0	904	0	78	0	0	0
AMBIENT												
RELATED												
PROJECT												
TOTAL	0	945	118	160	444	0	904	0	78	0	0	0

LANE:

Signal Configurations:

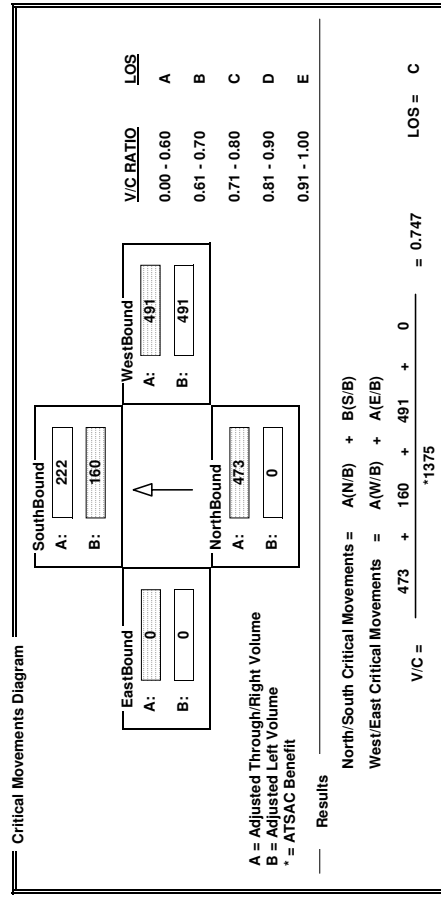

CalcaDB

INTERSECTION DATA SUMMARY SHEET

N/S: W/E: I/S No:

AM/PM: Comments:

COUNT DATE: STUDY DATE: GROWTH FACTOR:

Volume/Lane/Signal Configurations

	NORTHBOUND			SOUTHBOUND			WESTBOUND			EASTBOUND		
	LT	TH	RT	LT	TH	RT	LT	TH	RT	LT	TH	RT
EXISTING	238	450	119	135	325	136	90	498	67	97	437	169
AMBIENT												
RELATED												
PROJECT												
TOTAL	238	450	119	135	325	136	90	498	67	97	437	169

LANE: 1 2 1 1 1 1 1 1 1 1 1 1 1

SIGNAL: Perm Auto Auto Perm Auto Perm Auto Perm Auto

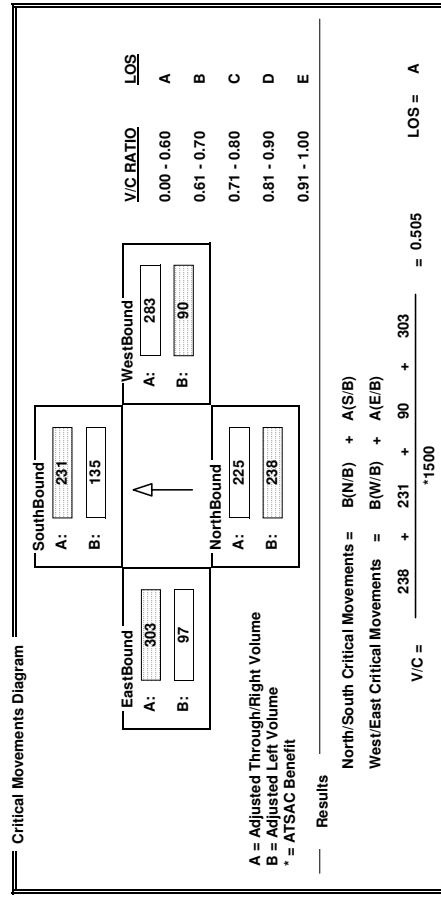

CalcaDB

INTERSECTION DATA SUMMARY SHEET

N/S: W/E: I/S No:

AM/PM: Comments:

COUNT DATE: STUDY DATE: GROWTH FACTOR:

Volume/Lane/Signal Configurations

	NORTHBOUND			SOUTHBOUND			WESTBOUND			EASTBOUND		
	LT	TH	RT	LT	TH	RT	LT	TH	RT	LT	TH	RT
EXISTING	113	741	284	68	615	28	130	864	58	26	1058	78
AMBIENT												
RELATED												
PROJECT												
TOTAL	113	741	284	68	615	28	130	864	58	26	1058	78

LANE: 1 2 1 1 1 1 1 1 1 1 1 1 1

SIGNAL: Prot-Fix Auto Auto Prot-Fix Auto Prot-Fix Auto Prot-Fix Auto

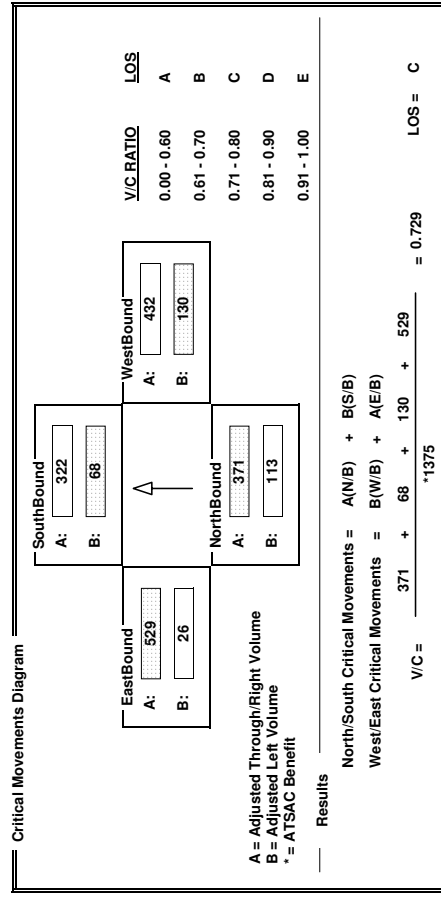

CalcaDB

INTERSECTION DATA SUMMARY SHEET

N/S: W/E: I/S No:

AM/PM: Comments:

COUNT DATE: STUDY DATE: GROWTH FACTOR:

Volume/Lane/Signal Configurations

	NORTHBOUND			SOUTHBOUND			WESTBOUND			EASTBOUND		
	LT	TH	RT	LT	TH	RT	LT	TH	RT	LT	TH	RT
EXISTING	167	1363	848	462	1758	84	187	320	314	330	280	162
AMBIENT												
RELATED												
PROJECT												
TOTAL	167	1363	848	462	1758	84	187	320	314	330	280	162
LANE	1	3	1	2	3	1	2	2	2	2	3	1
SIGNAL	Prot-Fix Auto			Prot-Fix Auto			Prot-Fix OLA			Prot-Fix Auto		

Critical Movements Diagram

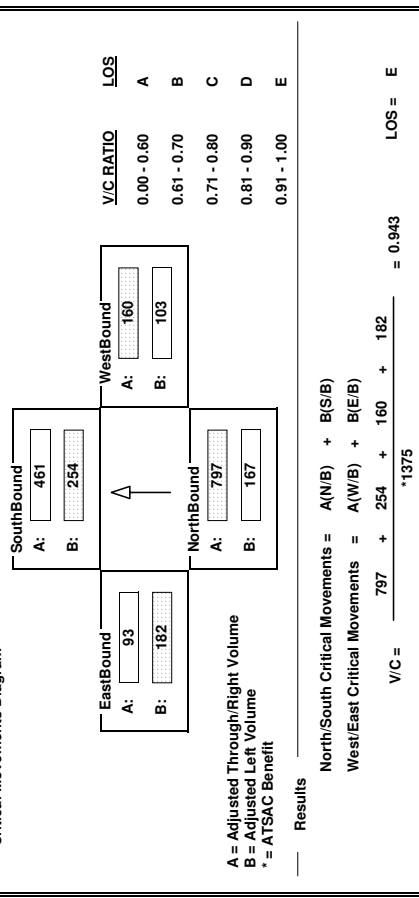

CalcaDB

INTERSECTION DATA SUMMARY SHEET

N/S: W/E: I/S No:

AM/PM: Comments:

COUNT DATE: STUDY DATE: GROWTH FACTOR:

Volume/Lane/Signal Configurations

	NORTHBOUND			SOUTHBOUND			WESTBOUND			EASTBOUND		
	LT	TH	RT	LT	TH	RT	LT	TH	RT	LT	TH	RT
EXISTING	108	1276	346	126	1223	49	368	216	100	79	259	69
AMBIENT												
RELATED												
PROJECT												
TOTAL	108	1276	346	126	1223	49	368	216	100	79	259	69
LANE	1	3	1	1	3	1	1	2	1	1	2	1
SIGNAL	Prot-Fix OLA			Prot-Fix OLA			Perm Auto			Prot-Fix OLA		

Critical Movements Diagram

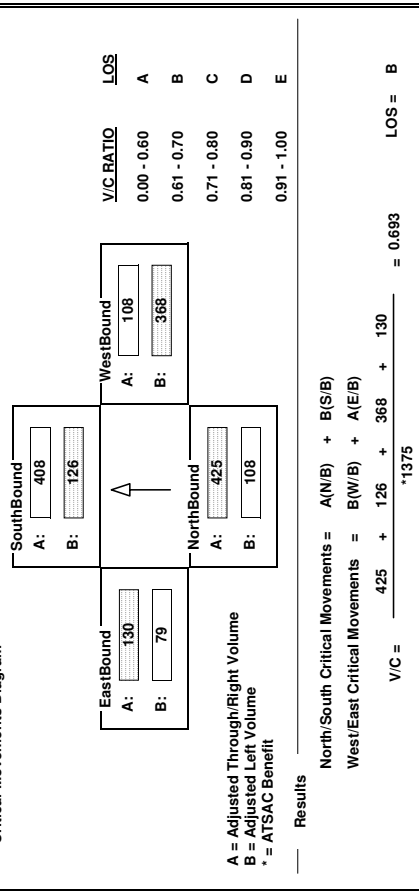

CalcaDB

INTERSECTION DATA SUMMARY SHEET

N/S: W/E: I/S No:
 AM/PM: Comments:
 COUNT DATE: STUDY DATE: GROWTH FACTOR:

Volume/Lane/Signal Configurations

	NORTHBOUND			SOUTHBOUND			WESTBOUND			EASTBOUND		
	LT	TH	RT	LT	TH	RT	LT	TH	RT	LT	TH	RT
EXISTING	56	1508	37	79	1528	268	36	68	85	256	57	58
AMBIENT												
RELATED												
PROJECT												
TOTAL	56	1508	37	79	1528	268	36	68	85	256	57	58
LANE	1	3	1	1	2	1	1	1	1	2	1	1
SIGNAL	Phasing RTOR Auto			Phasing RTOR Auto			Phasing RTOR Auto			Phasing RTOR Auto		

Critical Movements Diagram

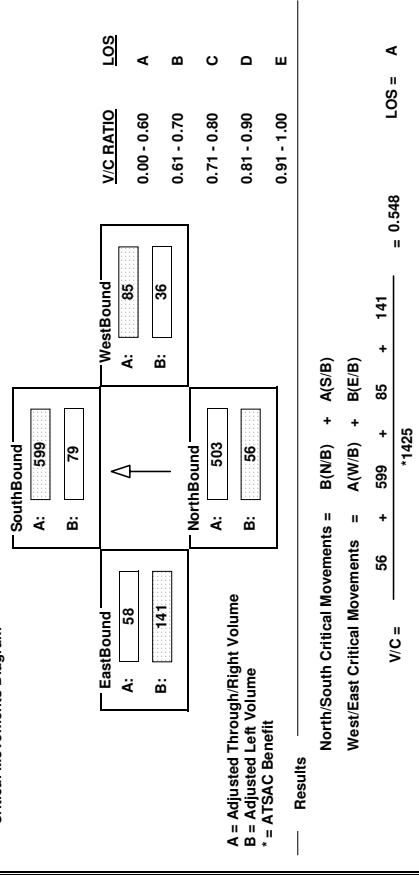

CalcaDB

INTERSECTION DATA SUMMARY SHEET

N/S: W/E: I/S No:
 AM/PM: Comments:
 COUNT DATE: STUDY DATE: GROWTH FACTOR:

Volume/Lane/Signal Configurations

	NORTHBOUND			SOUTHBOUND			WESTBOUND			EASTBOUND		
	LT	TH	RT	LT	TH	RT	LT	TH	RT	LT	TH	RT
EXISTING	0	530	146	146	635	0	932	0	82	0	0	0
AMBIENT												
RELATED												
PROJECT												
TOTAL	0	530	146	146	635	0	932	0	82	0	0	0
LANE	1	1	1	1	2	1	1	1	1	1	1	1
SIGNAL	Phasing RTOR OLA			Phasing RTOR Prot-Fix			Phasing RTOR Auto			Phasing RTOR Split		

Critical Movements Diagram

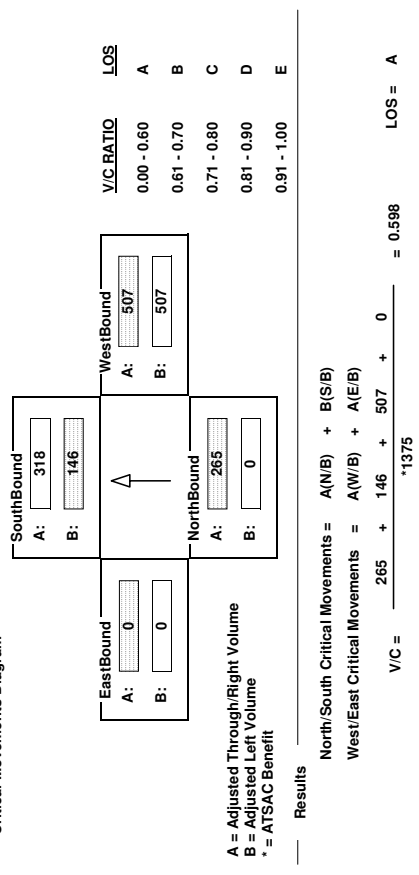

CalcaDB

INTERSECTION DATA SUMMARY SHEET

N/S: W/E: I/S No:

AM/PM: **PM** Comments: GROWTH FACTOR:

COUNT DATE: STUDY DATE:

Volume/Lane/Signal Configurations

	NORTHBOUND		SOUTHBOUND		WESTBOUND		EASTBOUND	
	LT	RT	LT	RT	LT	RT	LT	RT
EXISTING	189	827	302	353	128	206	859	173
AMBIENT								
RELATED								
PROJECT								
TOTAL	189	827	302	353	128	206	859	173

LANE: 1 2 1 1 1 1 1 2 1

SIGNAL: Prot-Fix RTOR Phasing RTOR Prot-Fix RTOR Prot-Fix RTOR

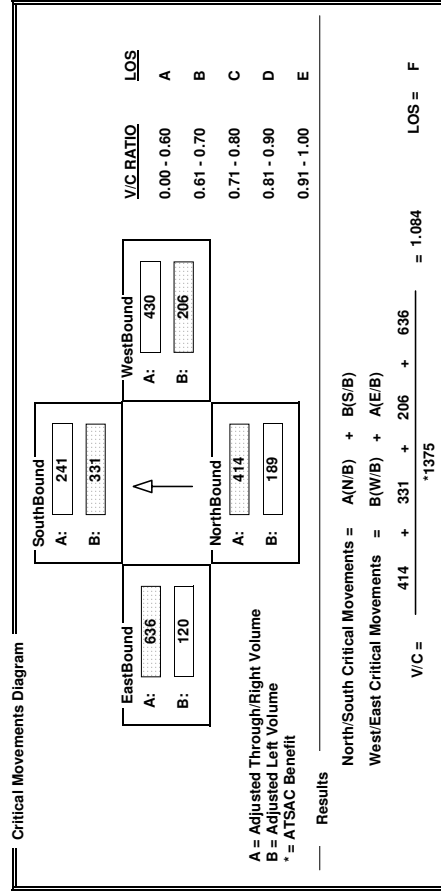

CalcaDB

INTERSECTION DATA SUMMARY SHEET

N/S: W/E: I/S No:

AM/PM: **PM** Comments: GROWTH FACTOR:

COUNT DATE: STUDY DATE:

Volume/Lane/Signal Configurations

	NORTHBOUND		SOUTHBOUND		WESTBOUND		EASTBOUND	
	LT	RT	LT	RT	LT	RT	LT	RT
EXISTING	234	693	127	438	126	102	464	62
AMBIENT								
RELATED								
PROJECT								
TOTAL	234	693	127	438	126	102	464	62

LANE: 1 2 1 1 1 1 1 1 1

SIGNAL: Perm RTOR Phasing RTOR Perm RTOR Perm RTOR

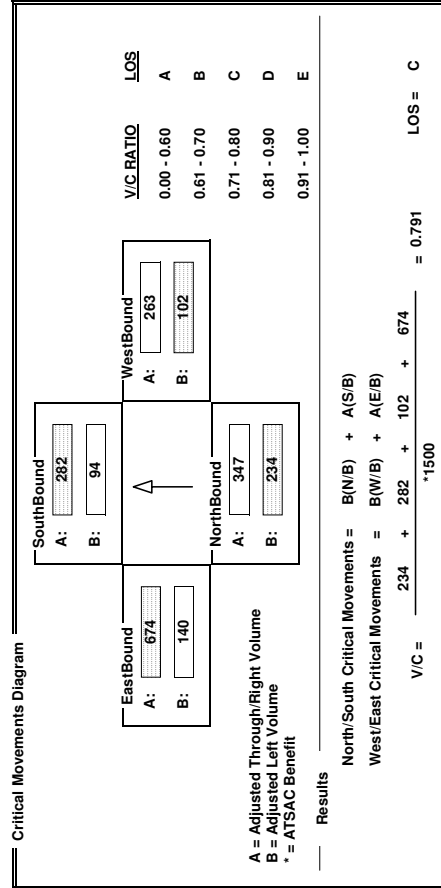

CalcaDB

INTERSECTION DATA SUMMARY SHEET

N/S: Sepulveda Blvd W/E: Imperial Hwy I/S No: 71
 AM/PM: **PM** Comments: MAP 3 Future 2013 with Project
 COUNT DATE: STUDY DATE: GROWTH FACTOR:

Volume/Lane/Signal Configurations

	NORTHBOUND			SOUTHBOUND			WESTBOUND			EASTBOUND		
	LT	TH	RT	LT	TH	RT	LT	TH	RT	LT	TH	RT
EXISTING	177	1648	1193	393	2368	155	242	352	382	188	318	168
AMBIENT												
RELATED												
PROJECT												
TOTAL	177	1648	1193	393	2368	155	242	352	382	188	318	168

LANE	1	2	3	1	2	3	1	2	3	1	2	3
PHASING	↓	↓	↓	↓	↓	↓	↓	↓	↓	↓	↓	↓
RTOR	Auto	Auto	Auto	Auto	Auto	Auto	Auto	Auto	Auto	Auto	Auto	Auto
SIGNAL	Prot-Fix	Prot-Fix	Auto	Prot-Fix	Prot-Fix	Auto	Prot-Fix	Prot-Fix	OLA	Prot-Fix	Prot-Fix	Auto

Critical Movements Diagram

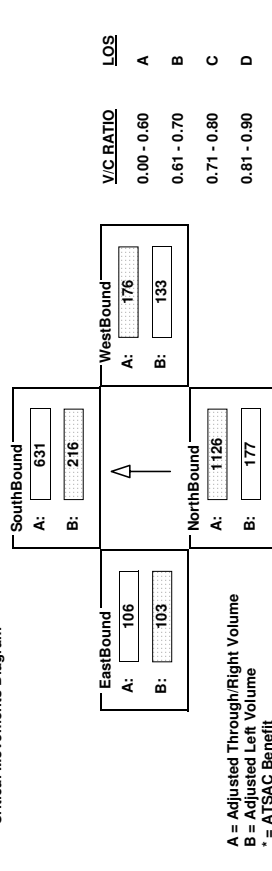

A = Adjusted Through/Right Volume
 B = Adjusted Left Volume
 * = ATSAC Benefit

Results

North/South Critical Movements = A(N/B) + B(S/B)
 West/East Critical Movements = A(W/B) + B(E/B)

V/C = $\frac{1126 + 216 + 176 + 103}{1375} = 1.109$ LOS = F

CalcaDB

INTERSECTION DATA SUMMARY SHEET

N/S: Sepulveda Blvd W/E: La Tijera Blvd I/S No: 101
 AM/PM: **PM** Comments: MAP 3 Future 2013 with Project
 COUNT DATE: STUDY DATE: GROWTH FACTOR:

Volume/Lane/Signal Configurations

	NORTHBOUND			SOUTHBOUND			WESTBOUND			EASTBOUND		
	LT	TH	RT	LT	TH	RT	LT	TH	RT	LT	TH	RT
EXISTING	176	1634	174	92	1286	86	344	387	59	89	446	88
AMBIENT												
RELATED												
PROJECT												
TOTAL	176	1634	174	92	1286	86	344	387	59	89	446	88

LANE	1	2	3	1	2	3	1	2	3	1	2	3
PHASING	↓	↓	↓	↓	↓	↓	↓	↓	↓	↓	↓	↓
RTOR	OLA	OLA	OLA	OLA	OLA	OLA	OLA	OLA	Auto	OLA	OLA	OLA
SIGNAL	Prot-Fix	Prot-Fix	OLA	Prot-Fix	Prot-Fix	OLA	Prot-Fix	Prot-Fix	Auto	Prot-Fix	Prot-Fix	OLA

Critical Movements Diagram

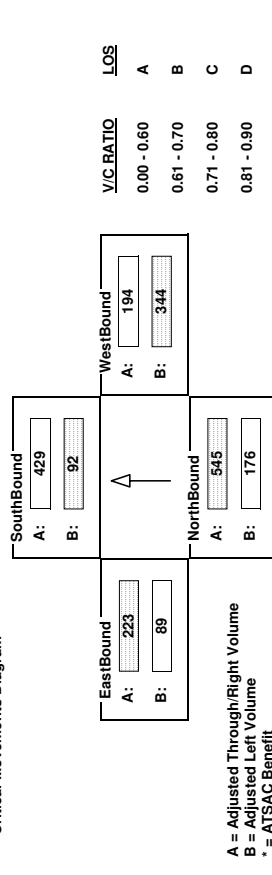

A = Adjusted Through/Right Volume
 B = Adjusted Left Volume
 * = ATSAC Benefit

Results

North/South Critical Movements = A(N/B) + B(S/B)
 West/East Critical Movements = B(W/B) + A(E/B)

V/C = $\frac{545 + 92 + 344 + 223}{1375} = 0.806$ LOS = D

CalcaDB

INTERSECTION DATA SUMMARY SHEET

N/S: W/E: I/S No:

AM/PM: Comments:

COUNT DATE: STUDY DATE: GROWTH FACTOR:

Volume/Lane/Signal Configurations

	NORTHBOUND			SOUTHBOUND			WESTBOUND			EASTBOUND		
	LT	TH	RT	LT	TH	RT	LT	TH	RT	LT	TH	RT
EXISTING	47	1912	35	126	2065	347	38	97	88	288	79	81
AMBIENT												
RELATED												
PROJECT												
TOTAL	47	1912	35	126	2065	347	38	97	88	288	79	81

LANE: 1 3 1 1 1 2 1 1 0 1 1 1 1

Signal Configurations: Phasing RTOR Auto Perm RTOR Auto Split Auto

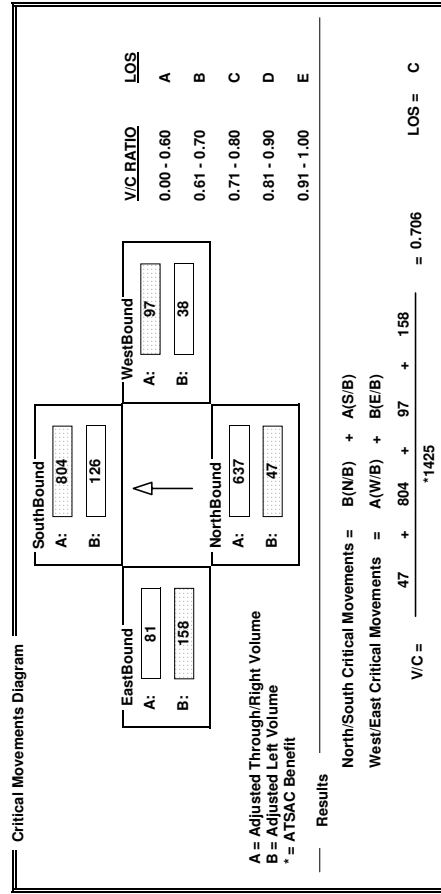

CalcaDB

INTERSECTION DATA SUMMARY SHEET

N/S: W/E: I/S No:

AM/PM: Comments:

COUNT DATE: STUDY DATE: GROWTH FACTOR:

Volume/Lane/Signal Configurations

	NORTHBOUND			SOUTHBOUND			WESTBOUND			EASTBOUND		
	LT	TH	RT	LT	TH	RT	LT	TH	RT	LT	TH	RT
EXISTING	0	648	86	234	834	0	811	0	180	0	0	0
AMBIENT												
RELATED												
PROJECT												
TOTAL	0	648	86	234	834	0	811	0	180	0	0	0

LANE: 1 1 1 1 1 2 1 1 1 1

Signal Configurations: Phasing RTOR OLA Prot-Fix Auto Split Auto

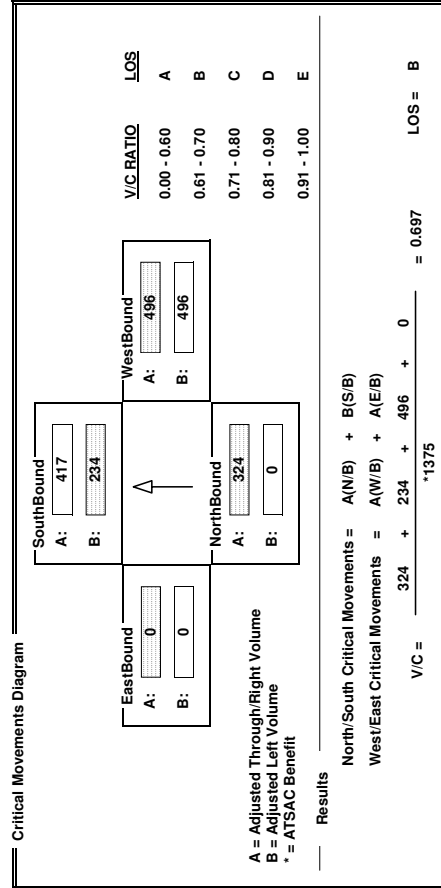

CalcaDB

INTERSECTION DATA SUMMARY SHEET

N/S: W/E: I/S No:

AM/PM: Comments:

COUNT DATE: STUDY DATE: GROWTH FACTOR:

Volume/Lane/Signal Configurations

	NORTHBOUND		SOUTHBOUND		WESTBOUND		EASTBOUND			
	LT	TH	LT	TH	LT	TH	LT	TH		
EXISTING	258	552	149	67	447	120	99	103	238	158
AMBIENT										
RELATED										
PROJECT										
TOTAL	258	552	149	67	447	120	99	103	238	158

LANE: 1 2 1 1 1 1 1 1 1 1 1 1

Phasing: RTOR Auto Auto Auto RTOR RTOR RTOR RTOR

SIGNAL: Perm Auto Auto Auto Perm Perm Perm Perm

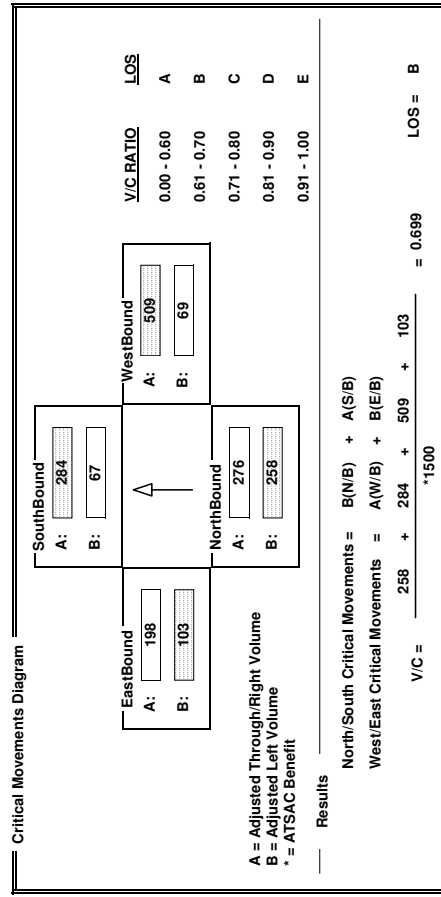

CalcaDB

INTERSECTION DATA SUMMARY SHEET

N/S: W/E: I/S No:

AM/PM: Comments:

COUNT DATE: STUDY DATE: GROWTH FACTOR:

Volume/Lane/Signal Configurations

	NORTHBOUND		SOUTHBOUND		WESTBOUND		EASTBOUND		
	LT	TH	LT	TH	LT	TH	LT	TH	
EXISTING	119	643	87	76	699	29	136	1205	208
AMBIENT									
RELATED									
PROJECT									
TOTAL	119	643	87	76	699	29	136	1205	208

LANE: 1 2 1 1 1 1 1 1 1 1

Phasing: RTOR Auto Auto Auto RTOR RTOR RTOR RTOR

SIGNAL: Prot-Fix Auto Auto Auto Prot-Fix Auto Auto Auto

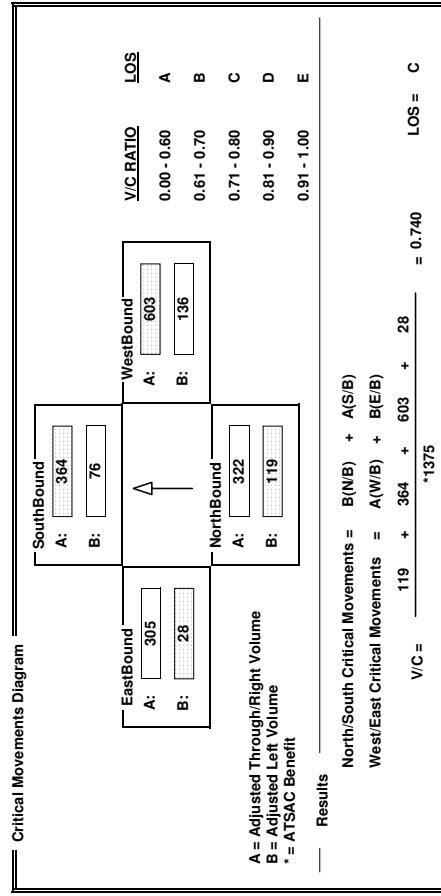

CalcaDB

INTERSECTION DATA SUMMARY SHEET

N/S: Sepulveda Blvd W/E: Imperial Hwy I/S No: 71
 AM/PM: AM Comments: MAP 4 Future 2013 w/o Project
 COUNT DATE: STUDY DATE: GROWTH FACTOR:

Volume/Lane/Signal Configurations

	NORTHBOUND			SOUTHBOUND			WESTBOUND			EASTBOUND		
	LT	TH	RT	LT	TH	RT	LT	TH	RT	LT	TH	RT
EXISTING	138	1668	712	279	2091	325	199	329	322	219	277	211
AMBIENT												
RELATED												
PROJECT												
TOTAL	138	1668	712	279	2091	325	199	329	322	219	277	211
LANE	1	3	1	2	3	1	2	2	2	2	3	1
SIGNAL	Prot-Fix Auto			Prot-Fix Auto			Prot-Fix OLA			Prot-Fix Auto		

Critical Movements Diagram

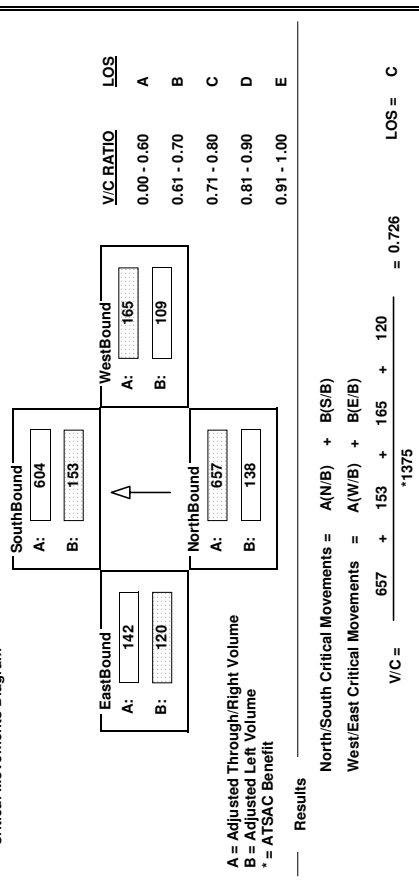

CalcaDB

INTERSECTION DATA SUMMARY SHEET

N/S: Sepulveda Blvd W/E: La Tijera Blvd I/S No: 101
 AM/PM: AM Comments: MAP 4 Future 2013 w/o Project
 COUNT DATE: STUDY DATE: GROWTH FACTOR:

Volume/Lane/Signal Configurations

	NORTHBOUND			SOUTHBOUND			WESTBOUND			EASTBOUND		
	LT	TH	RT	LT	TH	RT	LT	TH	RT	LT	TH	RT
EXISTING	107	1385	140	65	1088	59	424	199	38	49	319	79
AMBIENT												
RELATED												
PROJECT												
TOTAL	107	1385	140	65	1088	59	424	199	38	49	319	79
LANE	1	3	1	1	3	1	1	2	1	1	2	1
SIGNAL	Prot-Fix OLA			Prot-Fix OLA			Perm Auto			Prot-Fix OLA		

Critical Movements Diagram

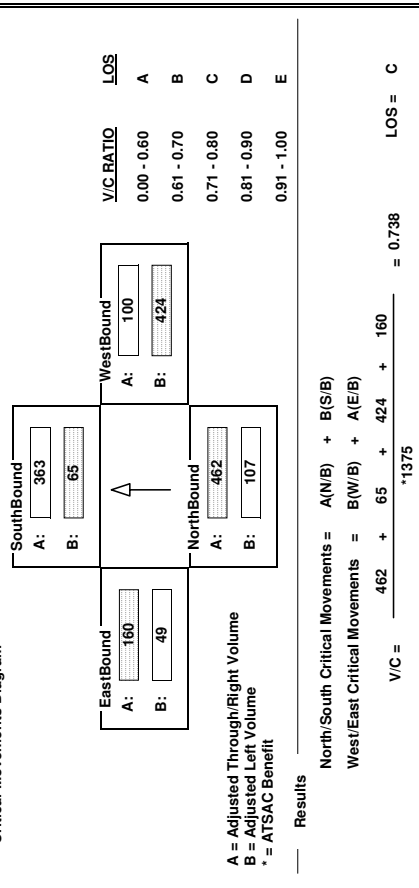

CalcaDB

INTERSECTION DATA SUMMARY SHEET

N/S: W/E: I/S No:

AM/PM: Comments:

COUNT DATE: STUDY DATE: GROWTH FACTOR:

Volume/Lane/Signal Configurations

	NORTHBOUND			SOUTHBOUND			WESTBOUND			EASTBOUND		
	LT	TH	RT	LT	TH	RT	LT	TH	RT	LT	TH	RT
EXISTING	0	941	119	160	428	0	907	0	76	0	0	0
AMBIENT												
RELATED												
PROJECT												
TOTAL	0	941	119	160	428	0	907	0	76	0	0	0

LANE: 1 1 1 1 1 1 1 1 1 1 1 1 1

SIGNAL: Perm OLA RTOR Auto Prot-Fix Auto Split Auto

Critical Movements Diagram

SouthBound: A: 214, B: 160
WestBound: A: 492, B: 492
NorthBound: A: 471, B: 0
EastBound: A: 0, B: 0

V/C RATIO: A: 0.00 - 0.60, B: 0.61 - 0.70, C: 0.71 - 0.80, D: 0.81 - 0.90, E: 0.91 - 1.00

Results: North/South Critical Movements = A(N/B) + B(S/B) = 214 + 160 = 374
West/East Critical Movements = A(W/B) + A(E/B) = 492 + 0 = 492
V/C = 374 + 492 + 0 = 866 = 0.747 LOS = C

CalcaDB

INTERSECTION DATA SUMMARY SHEET

N/S: W/E: I/S No:

AM/PM: Comments:

COUNT DATE: STUDY DATE: GROWTH FACTOR:

Volume/Lane/Signal Configurations

	NORTHBOUND			SOUTHBOUND			WESTBOUND			EASTBOUND		
	LT	TH	RT	LT	TH	RT	LT	TH	RT	LT	TH	RT
EXISTING	47	1954	18	88	1204	192	29	125	248	598	47	58
AMBIENT												
RELATED												
PROJECT												
TOTAL	47	1954	18	88	1204	192	29	125	248	598	47	58

LANE: 1 3 1 1 1 2 1 1 1 1 1 1 1

SIGNAL: Perm RTOR Auto RTOR Auto Split Auto

Critical Movements Diagram

SouthBound: A: 465, B: 88
WestBound: A: 248, B: 29
NorthBound: A: 651, B: 47
EastBound: A: 58, B: 329

V/C RATIO: A: 0.00 - 0.60, B: 0.61 - 0.70, C: 0.71 - 0.80, D: 0.81 - 0.90, E: 0.91 - 1.00

Results: North/South Critical Movements = A(N/B) + B(S/B) = 465 + 88 = 553
West/East Critical Movements = A(W/B) + B(E/B) = 248 + 29 = 277
V/C = 553 + 277 = 830 = 0.854 LOS = D

CalcaDB

INTERSECTION DATA SUMMARY SHEET

N/S: W/E: I/S No:

AM/PM: Comments:

COUNT DATE: STUDY DATE: GROWTH FACTOR:

Volume/Lane/Signal Configurations

	NORTHBOUND			SOUTHBOUND			WESTBOUND			EASTBOUND		
	LT	TH	RT	LT	TH	RT	LT	TH	RT	LT	TH	RT
EXISTING	116	699	312	69	600	29	130	845	59			68
AMBIENT												
RELATED												
PROJECT												
TOTAL	116	699	312	69	600	29	130	845	59			68

LANE: 1 2 1 1 1 1 1 1 2 1 1 2 1

Phasing: RTOR RTOR RTOR RTOR RTOR RTOR RTOR RTOR RTOR RTOR RTOR RTOR RTOR

SIGNAL: Prot-Fix Auto Auto Auto Auto Auto Auto Auto Auto Auto Auto

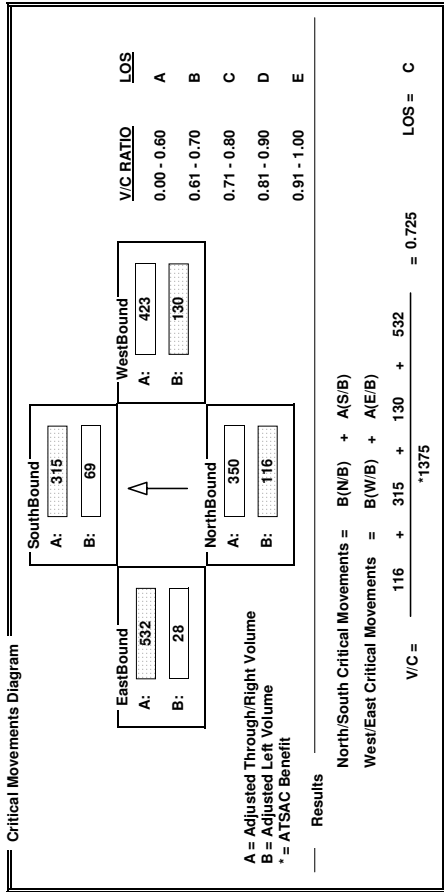

CalcaDB

INTERSECTION DATA SUMMARY SHEET

N/S: W/E: I/S No:

AM/PM: Comments:

COUNT DATE: STUDY DATE: GROWTH FACTOR:

Volume/Lane/Signal Configurations

	NORTHBOUND			SOUTHBOUND			WESTBOUND			EASTBOUND		
	LT	TH	RT	LT	TH	RT	LT	TH	RT	LT	TH	RT
EXISTING	228	467	120	147	320	127	90	505	74	99	445	170
AMBIENT												
RELATED												
PROJECT												
TOTAL	228	467	120	147	320	127	90	505	74	99	445	170

LANE: 1 2 1 1 1 1 1 1 1 1 1 1 1

Phasing: Perm RTOR Perm RTOR Perm RTOR Perm RTOR Perm RTOR Perm RTOR Perm RTOR

SIGNAL: Perm Auto Auto Auto Auto Auto Auto Auto Auto Auto Auto

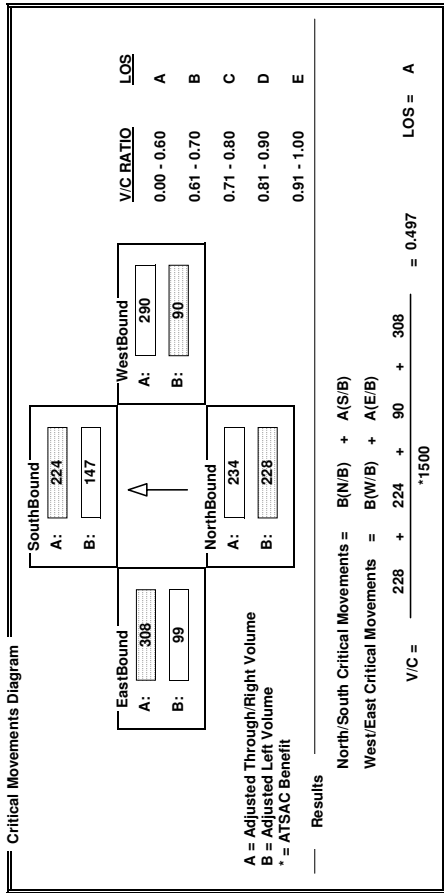

CalcaDB

INTERSECTION DATA SUMMARY SHEET

N/S: Sepulveda Blvd W/E: Imperial Hwy I/S No: 71
 AM/PM: MD Comments: MAP 4 Future 2013 w/o Project
 COUNT DATE: STUDY DATE: GROWTH FACTOR:

Volume/Lane/Signal Configurations

	NORTHBOUND			SOUTHBOUND			WESTBOUND			EASTBOUND		
	LT	TH	RT	LT	TH	RT	LT	TH	RT	LT	TH	RT
EXISTING	169	1280	876	499	1769	89	188	322	284	380	280	158
AMBIENT												
RELATED												
PROJECT												
TOTAL	169	1280	876	499	1769	89	188	322	284	380	280	158
LANE	1	3	1	2	3	1	2	2	2	2	3	1
SIGNAL	Prot-Fix Auto			Prot-Fix Auto			Prot-Fix OLA			Prot-Fix Auto		

Critical Movements Diagram

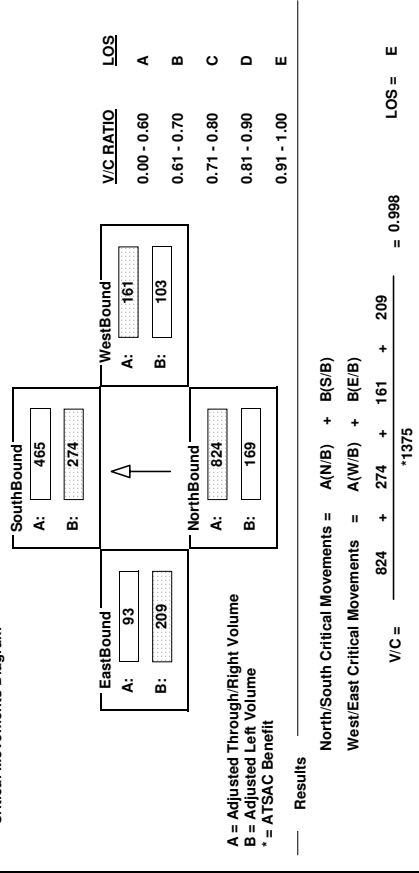

CalcaDB

INTERSECTION DATA SUMMARY SHEET

N/S: Sepulveda Blvd W/E: La Tijera Blvd I/S No: 101
 AM/PM: MD Comments: MAP 4 Future 2013 w/o Project
 COUNT DATE: STUDY DATE: GROWTH FACTOR:

Volume/Lane/Signal Configurations

	NORTHBOUND			SOUTHBOUND			WESTBOUND			EASTBOUND		
	LT	TH	RT	LT	TH	RT	LT	TH	RT	LT	TH	RT
EXISTING	109	1212	384	148	1162	49	292	218	110	79	259	70
AMBIENT												
RELATED												
PROJECT												
TOTAL	109	1212	384	148	1162	49	292	218	110	79	259	70
LANE	1	3	1	1	3	1	1	2	1	1	2	1
SIGNAL	Prot-Fix OLA			Prot-Fix OLA			Perm Auto			Prot-Fix OLA		

Critical Movements Diagram

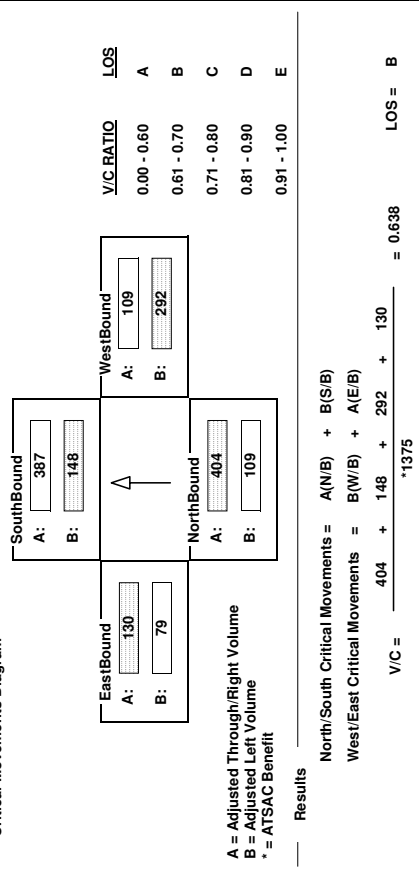

CalcaDB

INTERSECTION DATA SUMMARY SHEET

N/S: W/E: I/S No:
 AM/PM: Comments:
 COUNT DATE: STUDY DATE: GROWTH FACTOR:

Volume/Lane/Signal Configurations

	NORTHBOUND			SOUTHBOUND			WESTBOUND			EASTBOUND		
	LT	TH	RT	LT	TH	RT	LT	TH	RT	LT	TH	RT
EXISTING	58	1454	38	79	1469	299	38	74	87	258	63	59
AMBIENT												
RELATED												
PROJECT												
TOTAL	58	1454	38	79	1469	299	38	74	87	258	63	59
LANE	1	3	1	1	2	1	1	1	1	2	1	1
SIGNAL	Phasing RTOR Auto			Phasing RTOR Perm Auto			Phasing RTOR Auto			Phasing RTOR Split Auto		

Critical Movements Diagram

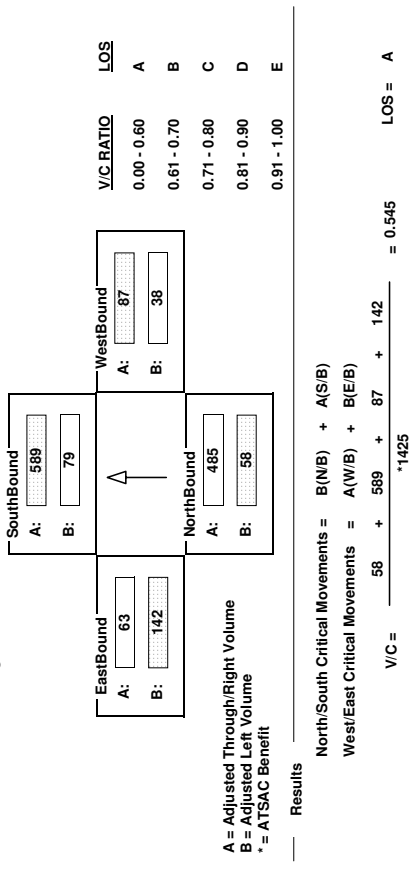

CalcaDB

INTERSECTION DATA SUMMARY SHEET

N/S: W/E: I/S No:
 AM/PM: Comments:
 COUNT DATE: STUDY DATE: GROWTH FACTOR:

Volume/Lane/Signal Configurations

	NORTHBOUND			SOUTHBOUND			WESTBOUND			EASTBOUND		
	LT	TH	RT	LT	TH	RT	LT	TH	RT	LT	TH	RT
EXISTING	0	508	148	148	644	0	923	0	78	0	0	0
AMBIENT												
RELATED												
PROJECT												
TOTAL	0	508	148	148	644	0	923	0	78	0	0	0
LANE	1	1	1	1	2	1	1	1	1	1	1	1
SIGNAL	Phasing RTOR OLA			Phasing RTOR Prot-Fix Auto			Phasing RTOR Auto			Phasing RTOR Split Auto		

Critical Movements Diagram

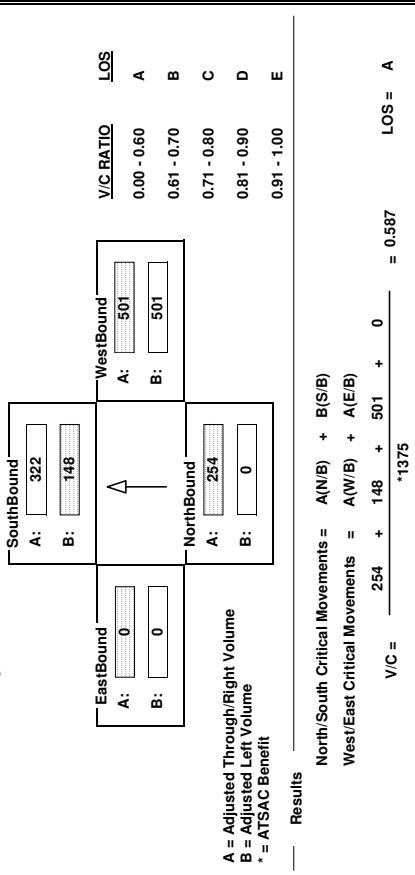

CalcaDB

INTERSECTION DATA SUMMARY SHEET

N/S: W/E: I/S No:

AM/PM: Comments:

COUNT DATE: STUDY DATE: GROWTH FACTOR:

Volume/Lane/Signal Configurations

	NORTHBOUND		SOUTHBOUND		WESTBOUND		EASTBOUND					
	LT	TH	LT	TH	LT	TH	LT	TH				
EXISTING	242	636	129	102	433	98	98	484	58	145	1101	319
AMBIENT												
RELATED												
PROJECT												
TOTAL	242	636	129	102	433	98	98	484	58	145	1101	319

LANE: 1 2 1 1 1 1 1 1 1 1 1 1 1

SIGNAL:

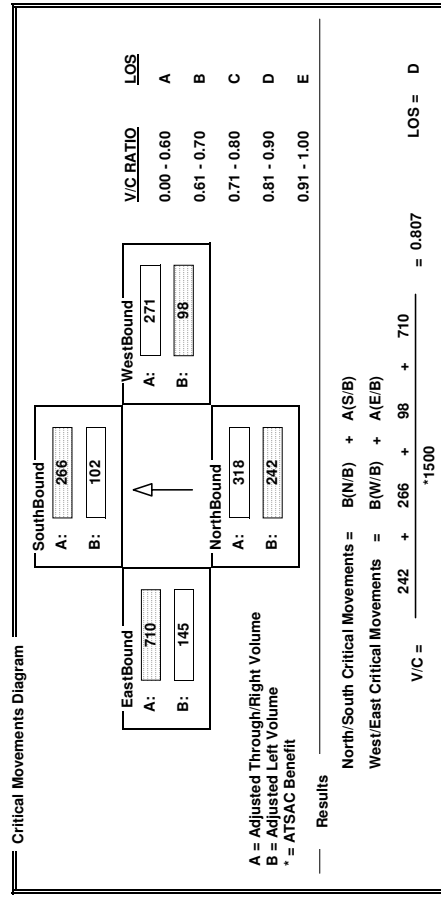

CalcaDB

INTERSECTION DATA SUMMARY SHEET

N/S: W/E: I/S No:

AM/PM: Comments:

COUNT DATE: STUDY DATE: GROWTH FACTOR:

Volume/Lane/Signal Configurations

	NORTHBOUND		SOUTHBOUND		WESTBOUND		EASTBOUND					
	LT	TH	LT	TH	LT	TH	LT	TH				
EXISTING	190	829	311	366	329	129	208	848	177	120	1281	328
AMBIENT												
RELATED												
PROJECT												
TOTAL	190	829	311	366	329	129	208	848	177	120	1281	328

LANE: 1 2 1 1 1 1 1 1 1 1 1 1 1

SIGNAL:

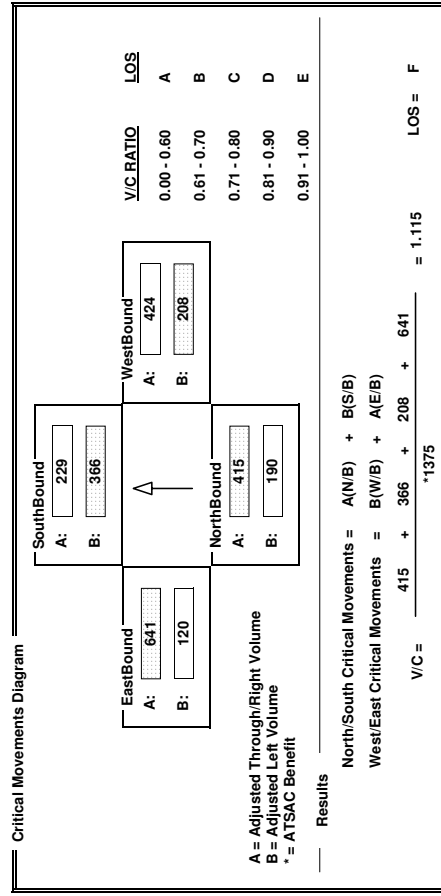

CalcaDB

INTERSECTION DATA SUMMARY SHEET

N/S: Sepulveda Blvd W/E: Imperial Hwy I/S No: 71
 AM/PM: **PM** Comments: MAP 4 Future 2013 w/o Project
 COUNT DATE: STUDY DATE: GROWTH FACTOR:

Volume/Lane/Signal Configurations

	NORTHBOUND			SOUTHBOUND			WESTBOUND			EASTBOUND		
	LT	TH	RT	LT	TH	RT	LT	TH	RT	LT	TH	RT
EXISTING	179	1589	1199	397	2344	193	246	371	377	191	321	169
AMBIENT												
RELATED												
PROJECT												
TOTAL	179	1589	1199	397	2344	193	246	371	377	191	321	169
LANE	1	3	1	2	3	1	2	2	2	2	3	1
SIGNAL	Prot-Fix Auto			Prot-Fix Auto			Prot-Fix OLA			Prot-Fix Auto		

Critical Movements Diagram

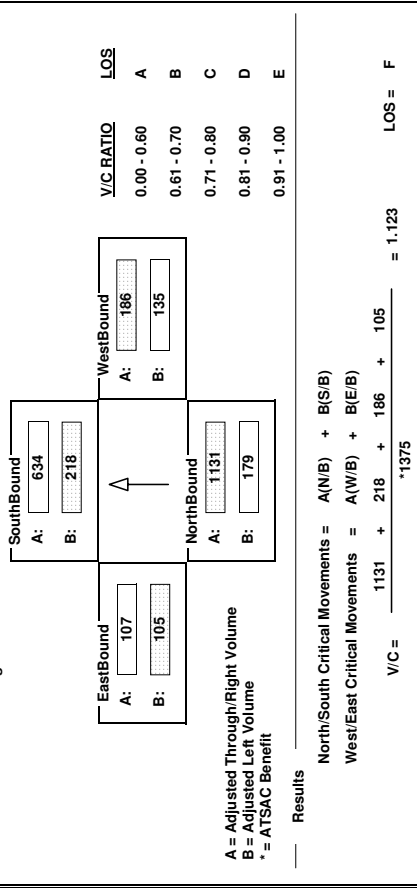

CalcaDB

INTERSECTION DATA SUMMARY SHEET

N/S: Sepulveda Blvd W/E: La Tijera Blvd I/S No: 101
 AM/PM: **PM** Comments: MAP 4 Future 2013 w/o Project
 COUNT DATE: STUDY DATE: GROWTH FACTOR:

Volume/Lane/Signal Configurations

	NORTHBOUND			SOUTHBOUND			WESTBOUND			EASTBOUND		
	LT	TH	RT	LT	TH	RT	LT	TH	RT	LT	TH	RT
EXISTING	188	1539	174	101	1198	88	320	389	60	89	448	94
AMBIENT												
RELATED												
PROJECT												
TOTAL	188	1539	174	101	1198	88	320	389	60	89	448	94
LANE	1	3	1	1	3	1	1	2	1	1	2	1
SIGNAL	Prot-Fix OLA			Prot-Fix OLA			Perm Auto			Prot-Fix OLA		

Critical Movements Diagram

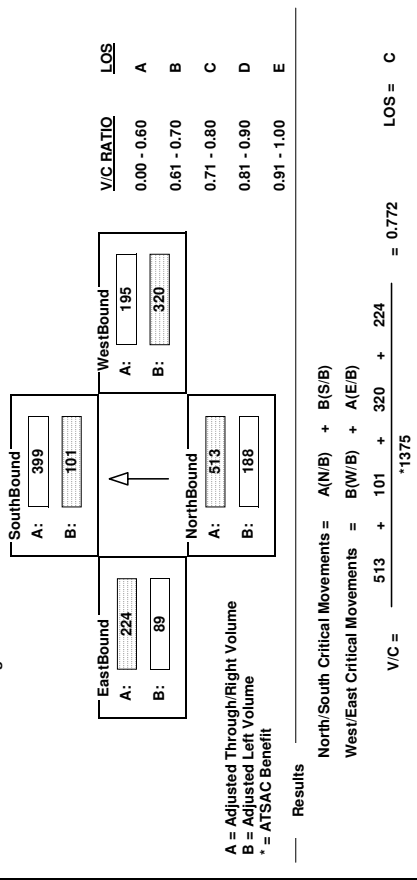

CalcaDB

INTERSECTION DATA SUMMARY SHEET

N/S: W/E: I/S No:

AM/PM: Comments:

COUNT DATE: STUDY DATE: GROWTH FACTOR:

Volume/Lane/Signal Configurations

	NORTHBOUND			SOUTHBOUND			WESTBOUND			EASTBOUND		
	LT	TH	RT	LT	TH	RT	LT	TH	RT	LT	TH	RT
EXISTING	0	624	88	244	833	0	813	0	177	0	0	0
AMBIENT												
RELATED												
PROJECT												
TOTAL	0	624	88	244	833	0	813	0	177	0	0	0

LANE:

SIGNAL:

Critical Movements Diagram

EastBound: A: B: V/C RATIO: 0.00 - 0.60

SouthBound: A: B: V/C RATIO: 0.61 - 0.70

WestBound: A: B: V/C RATIO: 0.71 - 0.80

NorthBound: A: B: V/C RATIO: 0.81 - 0.90

Results

North/South Critical Movements = A(N/B) + B(S/B) = 417 + 244 = 661

West/East Critical Movements = A(W/B) + A(E/B) = 495 + 495 = 990

V/C = $\frac{661}{990} = 0.668$

LOS = B

CalcaDB

INTERSECTION DATA SUMMARY SHEET

N/S: W/E: I/S No:

AM/PM: Comments:

COUNT DATE: STUDY DATE: GROWTH FACTOR:

Volume/Lane/Signal Configurations

	NORTHBOUND			SOUTHBOUND			WESTBOUND			EASTBOUND		
	LT	TH	RT	LT	TH	RT	LT	TH	RT	LT	TH	RT
EXISTING	48	1829	30	128	1999	349	39	109	89	319	85	69
AMBIENT												
RELATED												
PROJECT												
TOTAL	48	1829	30	128	1999	349	39	109	89	319	85	69

LANE:

SIGNAL:

Critical Movements Diagram

EastBound: A: B: V/C RATIO: 0.00 - 0.60

SouthBound: A: B: V/C RATIO: 0.61 - 0.70

WestBound: A: B: V/C RATIO: 0.71 - 0.80

NorthBound: A: B: V/C RATIO: 0.81 - 0.90

Results

North/South Critical Movements = B(N/B) + A(S/B) = 128 + 109 = 237

West/East Critical Movements = A(W/B) + B(E/B) = 109 + 39 = 148

V/C = $\frac{237}{148} = 1.601$

LOS = C

CalcaDB

INTERSECTION DATA SUMMARY SHEET

N/S: W/E: I/S No:
 AM/PM: Comments:
 COUNT DATE: STUDY DATE: GROWTH FACTOR:

Volume/Lane/Signal Configurations

	NORTHBOUND			SOUTHBOUND			WESTBOUND			EASTBOUND		
	LT	TH	RT	LT	TH	RT	LT	TH	RT	LT	TH	RT
EXISTING	119	699	95	84	731	29	144	1253	208	28	609	106
AMBIENT												
RELATED												
PROJECT												
TOTAL	119	699	95	84	731	29	144	1253	208	28	609	106

LANE:

Signal Configurations:

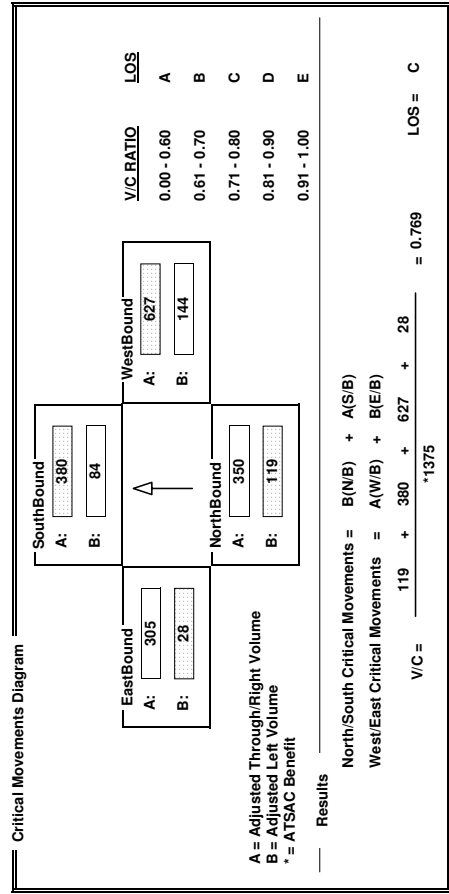

Developed by Chun Wong, 12/04

CalcaDB

INTERSECTION DATA SUMMARY SHEET

N/S: W/E: I/S No:
 AM/PM: Comments:
 COUNT DATE: STUDY DATE: GROWTH FACTOR:

Volume/Lane/Signal Configurations

	NORTHBOUND			SOUTHBOUND			WESTBOUND			EASTBOUND		
	LT	TH	RT	LT	TH	RT	LT	TH	RT	LT	TH	RT
EXISTING	258	600	149	67	455	128	69	982	99	111	262	158
AMBIENT												
RELATED												
PROJECT												
TOTAL	258	600	149	67	455	128	69	982	99	111	262	158

LANE:

Signal Configurations:

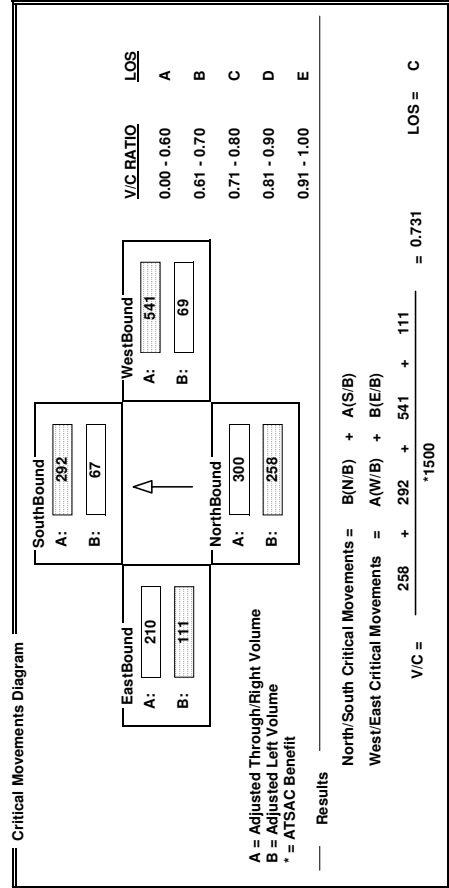

Developed by Chun Wong, 12/04

CalcaDB

INTERSECTION DATA SUMMARY SHEET

N/S: W/E: I/S No:

AM/PM: Comments:

COUNT DATE: STUDY DATE: GROWTH FACTOR:

Volume/Lane/Signal Configurations

	NORTHBOUND		SOUTHBOUND		WESTBOUND		EASTBOUND					
	LT	TH	LT	TH	LT	TH	LT	TH				
EXISTING	107	1545	156	65	1232	59	464	199	38	49	319	79
AMBIENT												
RELATED												
PROJECT												
TOTAL	107	1545	156	65	1232	59	464	199	38	49	319	79

LANE: 1 3 1 1 1 2 2 1 1 2 2 1 1

Signal: Prot-Fix OLA RTOR Phasing RTOR Phasing RTOR Prot-Fix OLA

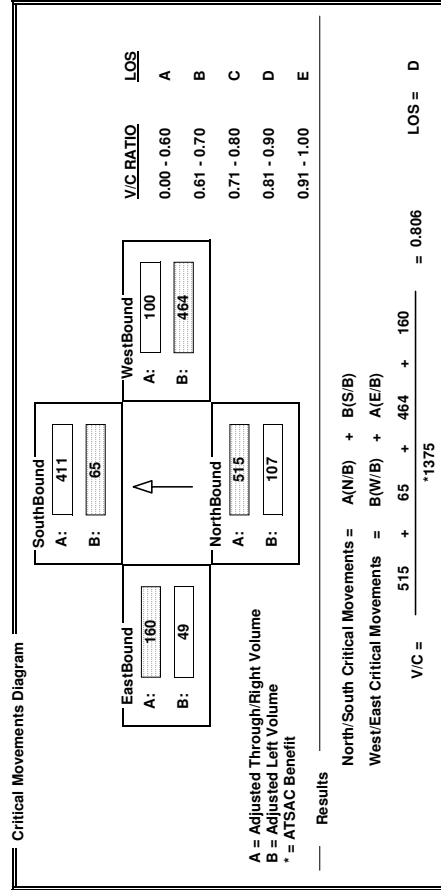

CalcaDB

INTERSECTION DATA SUMMARY SHEET

N/S: W/E: I/S No:

AM/PM: Comments:

COUNT DATE: STUDY DATE: GROWTH FACTOR:

Volume/Lane/Signal Configurations

	NORTHBOUND		SOUTHBOUND		WESTBOUND		EASTBOUND					
	LT	TH	LT	TH	LT	TH	LT	TH				
EXISTING	138	1740	712	319	2131	325	199	329	354	227	285	211
AMBIENT												
RELATED												
PROJECT												
TOTAL	138	1740	712	319	2131	325	199	329	354	227	285	211

LANE: 1 3 1 1 2 3 1 2 2 2 2 3 1

Signal: Prot-Fix Auto RTOR Phasing RTOR Phasing RTOR Prot-Fix OLA

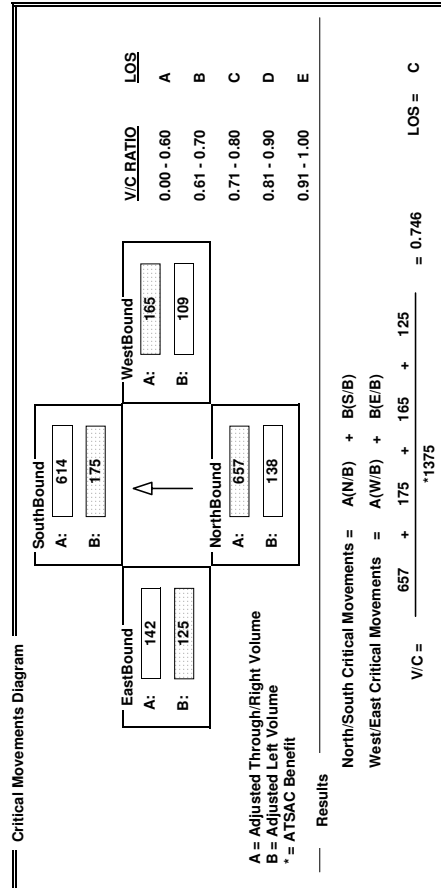

CalcaDB

INTERSECTION DATA SUMMARY SHEET

N/S: W/E: I/S No:
 AM/PM: Comments:
 COUNT DATE: STUDY DATE: GROWTH FACTOR:

Volume/Lane/Signal Configurations

	NORTHBOUND			SOUTHBOUND			WESTBOUND			EASTBOUND		
	LT	TH	RT	LT	TH	RT	LT	TH	RT	LT	TH	RT
EXISTING	47	2114	18	88	1268	192	29	125	248	598	47	58
AMBIENT												
RELATED												
PROJECT												
TOTAL	47	2114	18	88	1268	192	29	125	248	598	47	58

LANE:

SIGNAL:

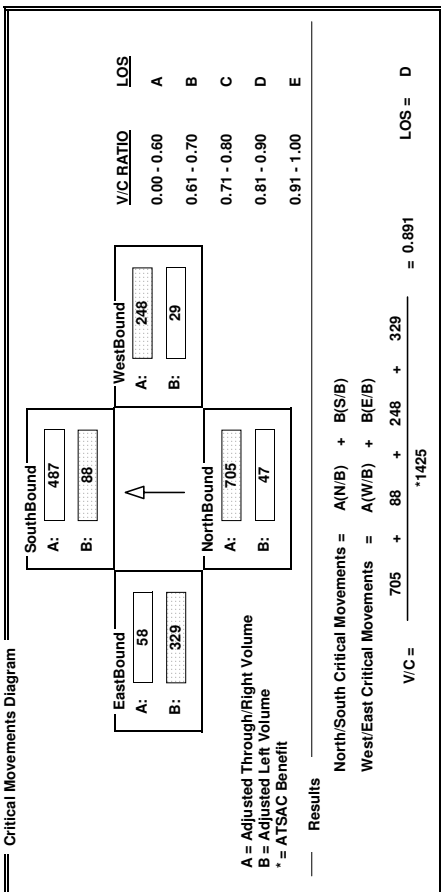

Developed by Chun Wong, 1/2/04

CalcaDB

INTERSECTION DATA SUMMARY SHEET

N/S: W/E: I/S No:
 AM/PM: Comments:
 COUNT DATE: STUDY DATE: GROWTH FACTOR:

Volume/Lane/Signal Configurations

	NORTHBOUND			SOUTHBOUND			WESTBOUND			EASTBOUND		
	LT	TH	RT	LT	TH	RT	LT	TH	RT	LT	TH	RT
EXISTING	0	973	119	160	452	0	947	0	84	0	0	0
AMBIENT												
RELATED												
PROJECT												
TOTAL	0	973	119	160	452	0	947	0	84	0	0	0

LANE:

SIGNAL:

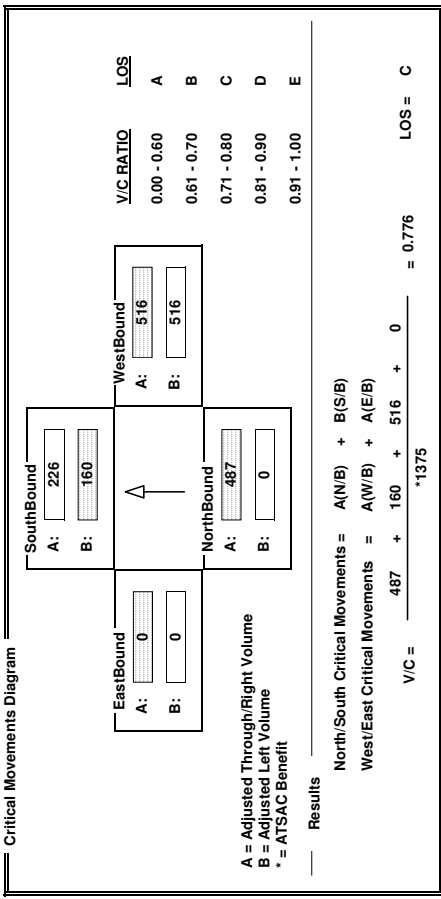

Developed by Chun Wong, 1/2/04

CalcaDB

INTERSECTION DATA SUMMARY SHEET

N/S: W/E: I/S No:

AM/PM: Comments:

COUNT DATE: STUDY DATE: GROWTH FACTOR:

Volume/Lane/Signal Configurations

	NORTHBOUND			SOUTHBOUND			WESTBOUND			EASTBOUND		
	LT	TH	RT	LT	TH	RT	LT	TH	RT	LT	TH	RT
EXISTING	244	475	120	147	328	143	90	529	74	99	469	170
AMBIENT												
RELATED												
PROJECT												
TOTAL	244	475	120	147	328	143	90	529	74	99	469	170

LANE: 1 2 1 1 1 1 1 1 1 1 1 1 1

SIGNAL: Perm RTOR Auto Perm Auto Perm Auto Perm Auto

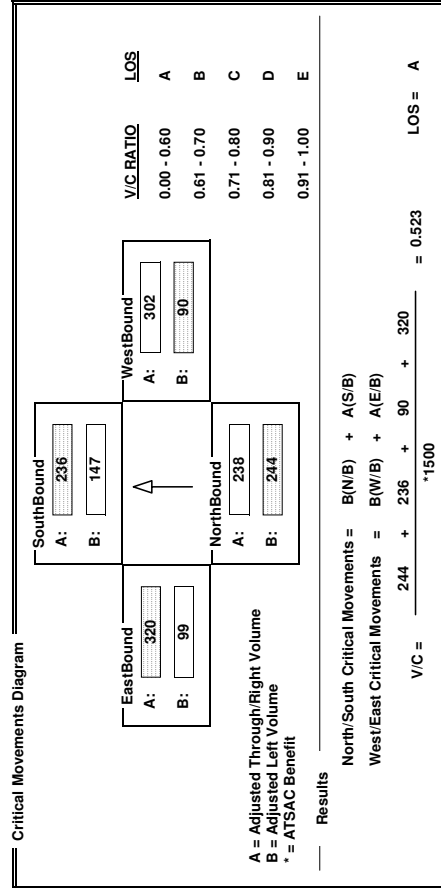

CalcaDB

INTERSECTION DATA SUMMARY SHEET

N/S: W/E: I/S No:

AM/PM: Comments:

COUNT DATE: STUDY DATE: GROWTH FACTOR:

Volume/Lane/Signal Configurations

	NORTHBOUND			SOUTHBOUND			WESTBOUND			EASTBOUND		
	LT	TH	RT	LT	TH	RT	LT	TH	RT	LT	TH	RT
EXISTING	116	755	312	69	632	29	130	877	59	28	1064	84
AMBIENT												
RELATED												
PROJECT												
TOTAL	116	755	312	69	632	29	130	877	59	28	1064	84

LANE: 1 2 1 1 1 1 1 1 1 1 1 1 1

SIGNAL: Prot-Fix RTOR Auto Prot-Fix Auto Prot-Fix Auto Prot-Fix Auto

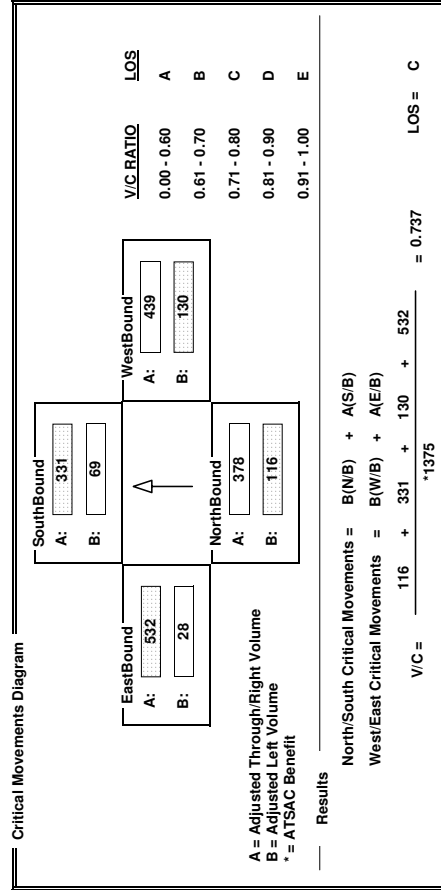

CalcaDB

INTERSECTION DATA SUMMARY SHEET

N/S: Sepulveda Blvd W/E: Imperial Hwy I/S No: 71
 AM/PM: **MD** Comments: MAP 4 Future 2013 with Project
 COUNT DATE: STUDY DATE: GROWTH FACTOR:

Volume/Lane/Signal Configurations

	NORTHBOUND			SOUTHBOUND			WESTBOUND			EASTBOUND		
	LT	TH	RT	LT	TH	RT	LT	TH	RT	LT	TH	RT
EXISTING	169	1392	884	531	1809	97	188	330	332	380	280	166
AMBIENT												
RELATED												
PROJECT												
TOTAL	169	1392	884	531	1809	97	188	330	332	380	280	166
LANE	1	3	1	2	3	1	2	2	2	2	3	1
SIGNAL	Prot-Fix Auto			Prot-Fix Auto			Prot-Fix OLA			Prot-Fix Auto		

Critical Movements Diagram

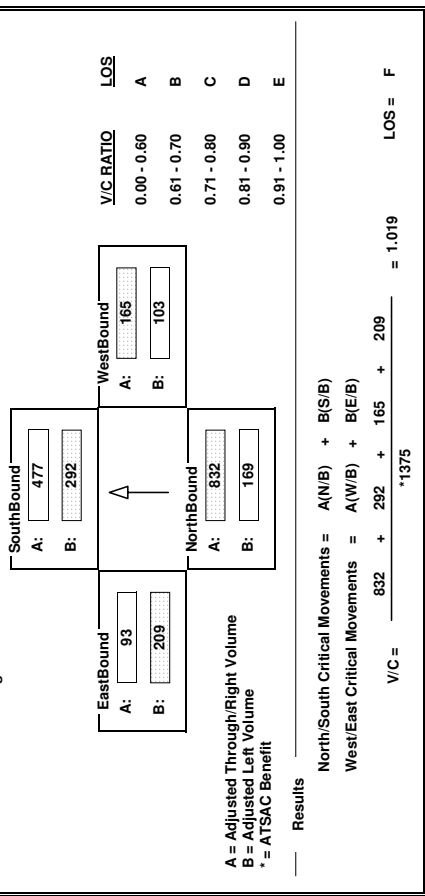

CalcaDB

INTERSECTION DATA SUMMARY SHEET

N/S: Sepulveda Blvd W/E: La Tijera Blvd I/S No: 101
 AM/PM: **MD** Comments: MAP 4 Future 2013 with Project
 COUNT DATE: STUDY DATE: GROWTH FACTOR:

Volume/Lane/Signal Configurations

	NORTHBOUND			SOUTHBOUND			WESTBOUND			EASTBOUND		
	LT	TH	RT	LT	TH	RT	LT	TH	RT	LT	TH	RT
EXISTING	109	1308	408	148	1266	49	404	218	110	79	259	70
AMBIENT												
RELATED												
PROJECT												
TOTAL	109	1308	408	148	1266	49	404	218	110	79	259	70
LANE	1	3	1	1	3	1	1	2	1	1	2	1
SIGNAL	Prot-Fix OLA			Prot-Fix OLA			Perm Auto			Prot-Fix OLA		

Critical Movements Diagram

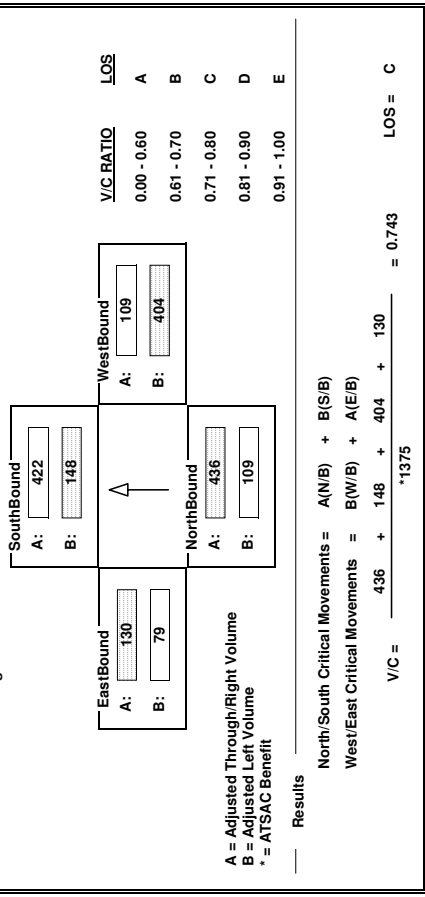

CalcaDB

INTERSECTION DATA SUMMARY SHEET

N/S: W/E: I/S No:

AM/PM: Comments:

COUNT DATE: STUDY DATE: GROWTH FACTOR:

Volume/Lane/Signal Configurations

	NORTHBOUND			SOUTHBOUND			WESTBOUND			EASTBOUND		
	LT	TH	RT	LT	TH	RT	LT	TH	RT	LT	TH	RT
EXISTING	0	540	148	148	652	0	971	0	86	0	0	0
AMBIENT												
RELATED												
PROJECT												
TOTAL	0	540	148	148	652	0	971	0	86	0	0	0

LANE:

SIGNAL:

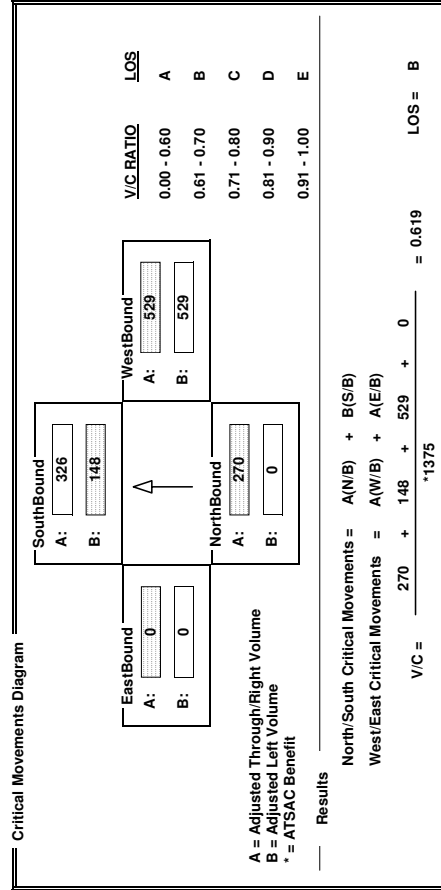

CalcaDB

INTERSECTION DATA SUMMARY SHEET

N/S: W/E: I/S No:

AM/PM: Comments:

COUNT DATE: STUDY DATE: GROWTH FACTOR:

Volume/Lane/Signal Configurations

	NORTHBOUND			SOUTHBOUND			WESTBOUND			EASTBOUND		
	LT	TH	RT	LT	TH	RT	LT	TH	RT	LT	TH	RT
EXISTING	58	1534	38	79	1549	299	38	74	87	258	63	59
AMBIENT												
RELATED												
PROJECT												
TOTAL	58	1534	38	79	1549	299	38	74	87	258	63	59

LANE:

SIGNAL:

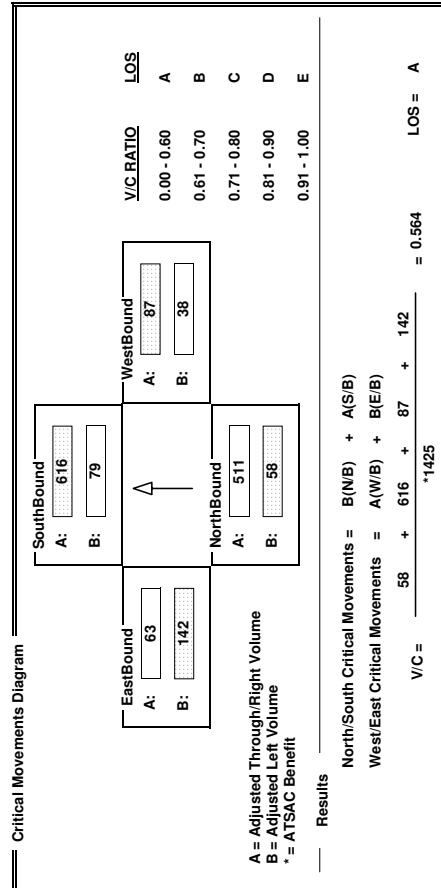

CalcaDB

INTERSECTION DATA SUMMARY SHEET

N/S: W/E: I/S No:

AM/PM: Comments:

COUNT DATE: STUDY DATE: GROWTH FACTOR:

Volume/Lane/Signal Configurations

	NORTHBOUND		SOUTHBOUND		WESTBOUND		EASTBOUND				
	LT	TH	LT	TH	LT	TH	LT	TH			
EXISTING	190	869	311	366	361	129	208	864	177	328	328
AMBIENT											
RELATED											
PROJECT											
TOTAL	190	869	311	366	361	129	208	864	177	328	328

LANE: 1 2 1 1 1 1 1 1 2 1 1 1

SIGNAL: Prot-Fix RTOR Phasing RTOR Prot-Fix RTOR Phasing RTOR Prot-Fix RTOR

Critical Movements Diagram

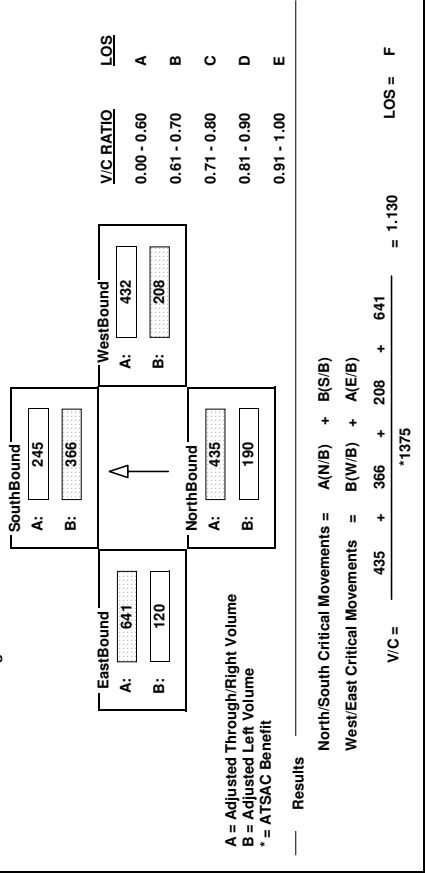

CalcaDB

INTERSECTION DATA SUMMARY SHEET

N/S: W/E: I/S No:

AM/PM: Comments:

COUNT DATE: STUDY DATE: GROWTH FACTOR:

Volume/Lane/Signal Configurations

	NORTHBOUND		SOUTHBOUND		WESTBOUND		EASTBOUND					
	LT	TH	LT	TH	LT	TH	LT	TH				
EXISTING	242	716	129	102	449	138	106	492	66	145	1125	319
AMBIENT												
RELATED												
PROJECT												
TOTAL	242	716	129	102	449	138	106	492	66	145	1125	319

LANE: 1 2 1 1 1 1 1 1 1 1 1 1 1

SIGNAL: Perm RTOR Phasing RTOR Perm RTOR Phasing RTOR Perm RTOR

Critical Movements Diagram

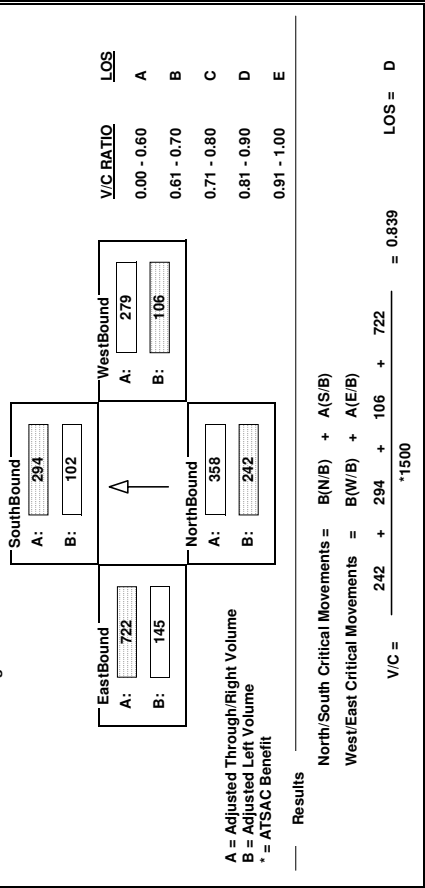

CalcaDB

INTERSECTION DATA SUMMARY SHEET

N/S: Sepulveda Blvd W/E: Imperial Hwy I/S No: 71
 AM/PM: **PM** Comments: MAP 4 Future 2013 with Project
 COUNT DATE: STUDY DATE: GROWTH FACTOR:

Volume/Lane/Signal Configurations

	NORTHBOUND			SOUTHBOUND			WESTBOUND			EASTBOUND		
	LT	TH	RT	LT	TH	RT	LT	TH	RT	LT	TH	RT
EXISTING	179	1669	1207	421	2424	193	246	371	401	199	329	169
AMBIENT												
RELATED												
PROJECT												
TOTAL	179	1669	1207	421	2424	193	246	371	401	199	329	169

LANE: 1 3 1 2 3 1 2 2 2 2 2 3 1

SIGNAL: Prot-Fix RTOR Phasing RTOR Prot-Fix Auto Auto OLA Auto

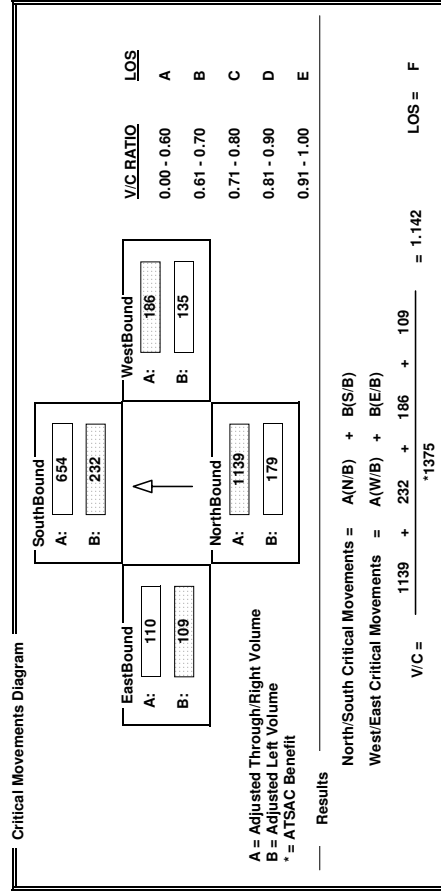

Developed by Chun Wong, 12/04

CalcaDB

INTERSECTION DATA SUMMARY SHEET

N/S: Sepulveda Blvd W/E: La Tijera Blvd I/S No: 101
 AM/PM: **PM** Comments: MAP 4 Future 2013 with Project
 COUNT DATE: STUDY DATE: GROWTH FACTOR:

Volume/Lane/Signal Configurations

	NORTHBOUND			SOUTHBOUND			WESTBOUND			EASTBOUND		
	LT	TH	RT	LT	TH	RT	LT	TH	RT	LT	TH	RT
EXISTING	188	1667	182	101	1318	88	392	389	60	89	448	94
AMBIENT												
RELATED												
PROJECT												
TOTAL	188	1667	182	101	1318	88	392	389	60	89	448	94

LANE: 1 3 1 1 3 1 1 1 2 1 1 2 1

SIGNAL: Prot-Fix RTOR Phasing RTOR Prot-Fix OLA Auto OLA

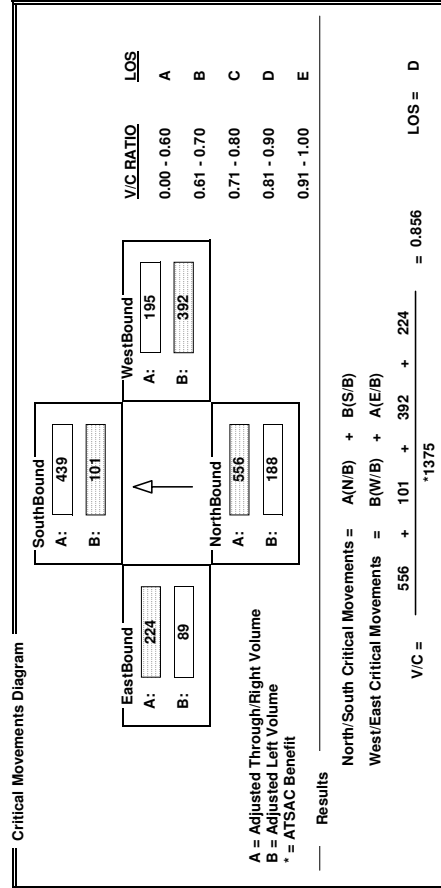

Developed by Chun Wong, 12/04

CalcaDB

INTERSECTION DATA SUMMARY SHEET

N/S: W/E: I/S No:
 AM/PM: Comments:
 COUNT DATE: STUDY DATE: GROWTH FACTOR:

Volume/Lane/Signal Configurations

	NORTHBOUND			SOUTHBOUND			WESTBOUND			EASTBOUND		
	LT	TH	RT	LT	TH	RT	LT	TH	RT	LT	TH	RT
EXISTING	48	1941	38	128	2087	349	39	109	89	319	85	85
AMBIENT												
RELATED												
PROJECT												
TOTAL	48	1941	38	128	2087	349	39	109	89	319	85	85

LANE:

Signal Configurations:

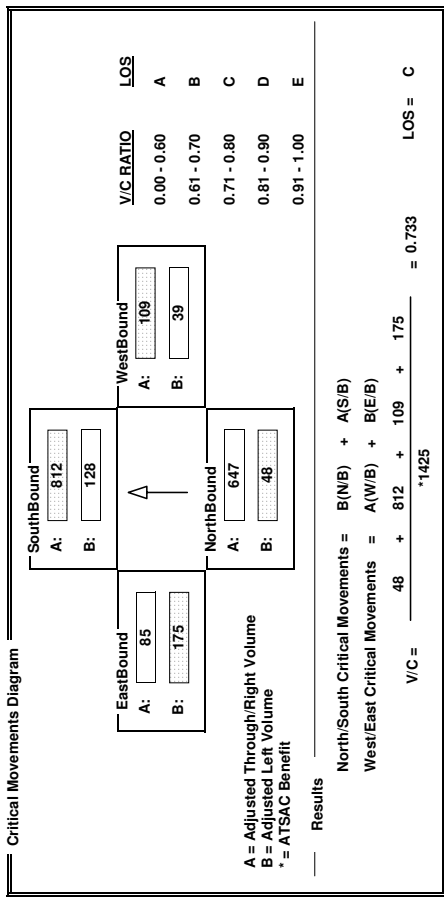

Developed by Chun Wong, 12/94

CalcaDB

INTERSECTION DATA SUMMARY SHEET

N/S: W/E: I/S No:
 AM/PM: Comments:
 COUNT DATE: STUDY DATE: GROWTH FACTOR:

Volume/Lane/Signal Configurations

	NORTHBOUND			SOUTHBOUND			WESTBOUND			EASTBOUND		
	LT	TH	RT	LT	TH	RT	LT	TH	RT	LT	TH	RT
EXISTING	0	664	88	252	857	0	861	0	185	0	0	0
AMBIENT												
RELATED												
PROJECT												
TOTAL	0	664	88	252	857	0	861	0	185	0	0	0

LANE:

Signal Configurations:

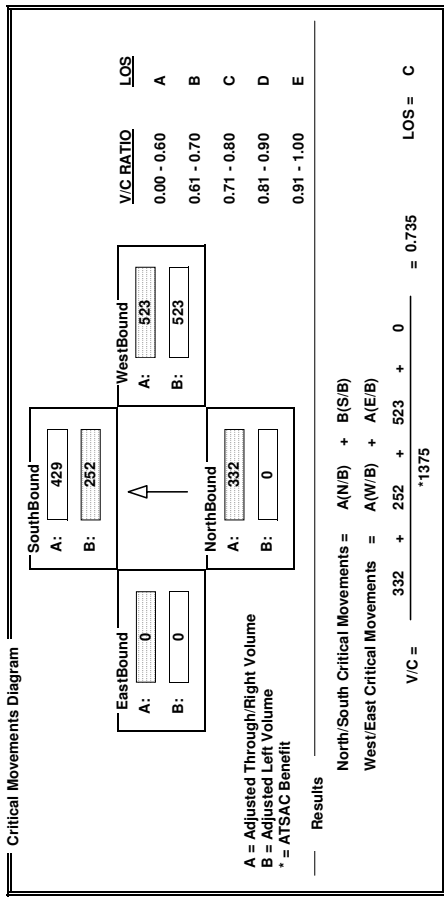

Developed by Chun Wong, 12/94